

60CM CONTEMPORARY OVENS

PLANNING GUIDE

SERIES 5 PYROLYTIC OVEN | OB60SBCPGB5

Note: This model is only available in England, Scotland and Wales.

INTRODUCTION

This comprehensive planning guide provides you with the framework and tools to achieve your desired design outcome with Fisher & Paykel appliances. In this guide, you will find a range of conceptual, detailed, and dimensional product information to bring your ideas to life and create spaces that truly reflect your vision.

SUPPORT

For additional design planning and installation support please contact the Fisher & Paykel design support team.
designsupport@fisherpaykel.com

NOTES

The models shown in this Planning Guide may not be available in all markets and are subject to change at any time. Refer to our website fisherpaykel.com for the latest document version. Product specifications may vary from those shown.
This Planning Guide should not be used as installation guidance for any product. Specific installation guidance will be available with the product on delivery and on our website.

CONCEPT DESIGN	PAGE
SPECIFICATION GUIDE	
Pyrolytic Oven	4
Pyrolytic Oven Specification	5

DEVELOPED AND DETAILED DESIGN	PAGE
DATA SHEETS	
Pyrolytic Oven	7

DEVELOPED AND DETAILED DESIGN	PAGE
--------------------------------------	-------------

SPECIFICATION GUIDE

SERIES 5



OVERVIEW

Designed to be distinctive and timeless, this Contemporary oven complements a wide range of kitchen styles. The pyrolytic self-cleaning function breaks down food residue for an easy clean, while the dial control with illuminated icons offers simple operation of 9 versatile functions including Air Fry and Pizza Bake.

PRODUCTS

OB60SBCPGB5 - Black
60cm Series 5 Contemporary Pyrolytic Oven

Note: This model is only available in England, Scotland and Wales.

SERIES & STYLE

Series 5
Contemporary



FEATURES

- 1 Contemporary style is distinctive and timeless to complement a wide range of kitchen styles
- 2 Self-cleaning pyrolytic function breaks down food residue for an easy clean
- 3 Generous 72L useable capacity
- 4 Dial control with illuminated icons for simple operation
- 5 Even heat distribution thanks to AeroTech™ technology
- 6 9 versatile functions including Air Fry and Pizza Bake

ACCESSORIES

- 1 Pyro-proof Side Ladders
- 2 Wire Shelf
- 3 Multi-functional Air Fry Tray
- 4 Roasting Dish

The models shown in this Planning Guide may not be available in all markets and are subject to change at any time. Product specifications may vary from those shown. This Planning Guide should not be used as installation guidance for any product. Further information is required to safely and correctly install the products featured here. Specific installation guidance will be available with the product on delivery and on our website fisherpaykel.com

SPECIFICATIONS

MODEL NUMBER

OB60SBCPGB5 60cm Series 5 Contemporary Pyrolytic Oven - Black

ELECTRICAL

Dedicated Circuit (A) 16

Rated Power (W) 2800 - 3300

Supply (Hz) 50

Voltage (V) 220 - 240

Connection Hard-wired, min 1500mm*

*The electrician is required to provide a free length of power supply cable extending at least 1500mm in front of the bottom edge of the cavity opening.

Note: For multi-residential installations, use the Rated Power to calculate the demand.

CAPACITY

Total Oven capacity 85L

WEIGHTS

Packaged 55kg

Unpackaged 45kg

PRODUCT DIMENSIONS

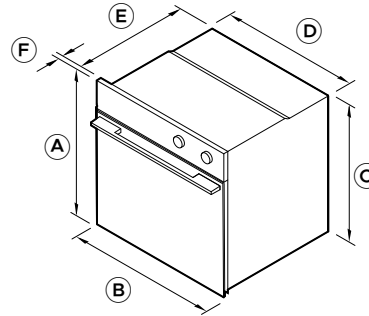

ISOMETRIC VIEW

	mm
A Overall product height	598
B Overall product width	596
C Chassis height	575
D Chassis width	556
E Chassis depth	545
F Front frame depth (excludes handle)	20
Door open depth at 90° (from product front)	447

CAVITY DIMENSIONS

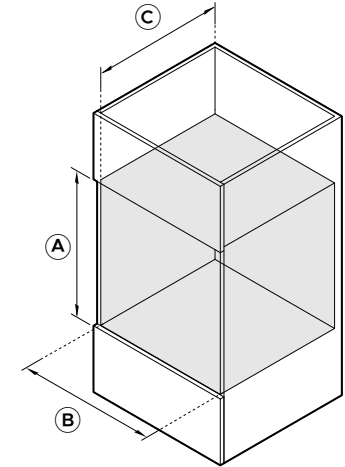

ISOMETRIC VIEW

	mm
A Cavity height	min 580
B Cavity width	min 560
C Cavity depth (from chassis front datum)	min 550

The models shown in this Planning Guide may not be available in all markets and are subject to change at any time. Product specifications may vary from those shown. This Planning Guide should not be used as installation guidance for any product. Further information is required to safely and correctly install the products featured here. Specific installation guidance will be available with the product on delivery and on our website fisherpaykel.com

DATA SHEETS

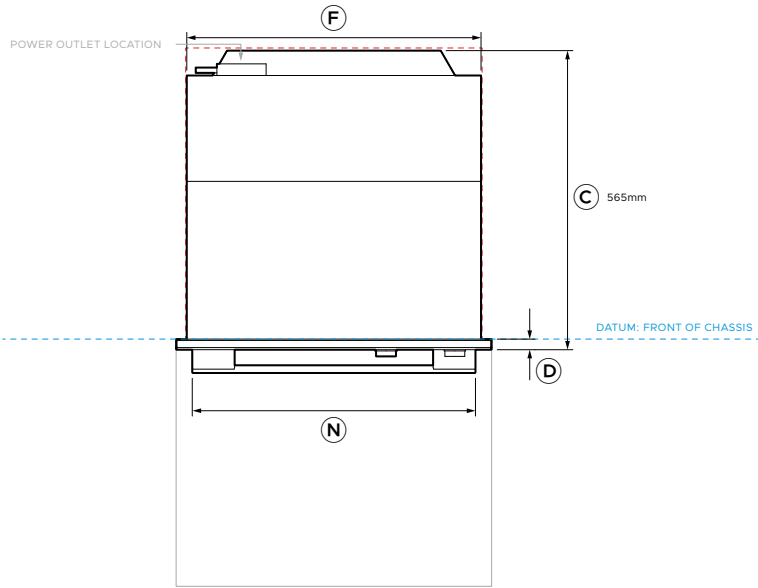

PLAN VIEW

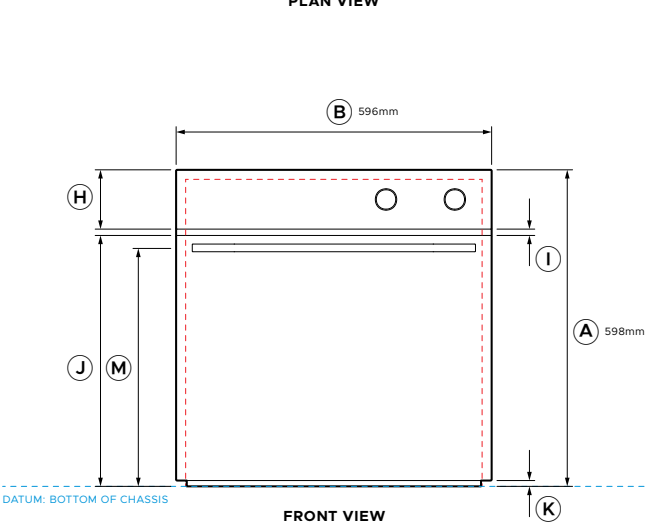
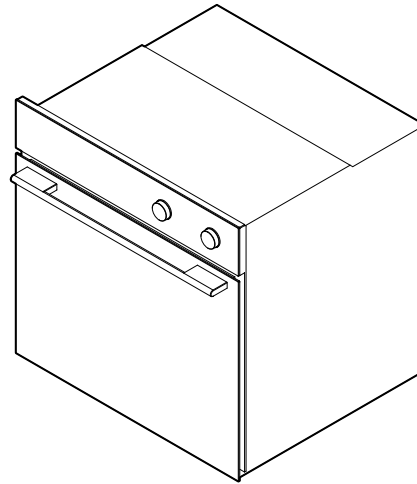

FRONT VIEW

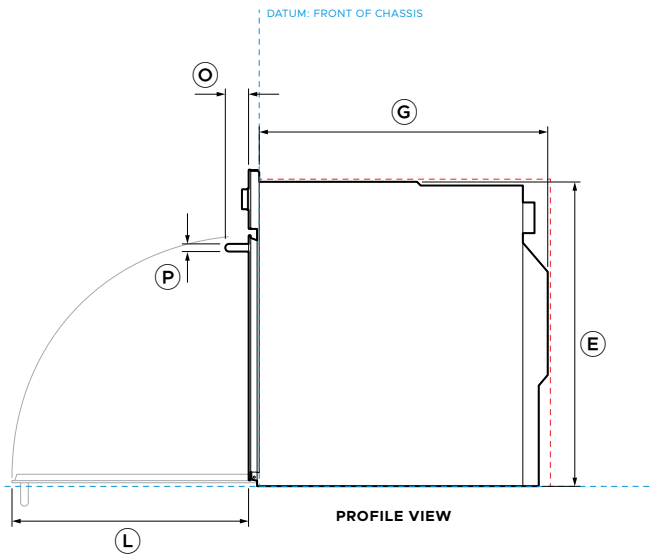

PROFILE VIEW

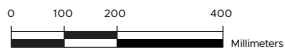

Model no:

OB60SBCPGB5

60cm Series 5 Contemporary Pyrolytic Oven - Black

Product Dimensions

	mm
A Overall product height	598
B Overall product width	596
C Overall product depth (excludes handle)	565
D Front frame depth (excludes handle)	20
E Chassis height	575
F Chassis width	556
G Chassis depth	545
H Control panel height	112
I Door-to-control panel gap	12
J Door upper edge height (from chassis base datum)	474
K Door lower edge height (from chassis base datum)	11
L Door open depth at 90° (from product front)	447
M Handle centreline height (from chassis base datum)	450.5
N Handle width	535
O Handle depth (projection)	44
P Handle thickness	15

Minimum Clearances

	mm
Cavity height	min 580
Cavity width	min 560
Cavity depth (from chassis front datum)	min 550
Front frame clearance - top & sides*	min 2

*Product requires no bottom clearance between product to cabinetry front panel or appliance.

----- INDICATES PRODUCT DATUM
 - - - - - INDICATES CABINERY CLEARANCES

IMPORTANT NOTE: Throughout this guide, dimensions may vary by ±2mm (1/16"). Please read the installation manual for detailed information on installing the product. For full installation instructions & specifications visit fisherpaykel.com

