

**INDUCTION COOKTOP**

---

# PLANNING GUIDE

---

**83CM INDUCTION COOKTOP WITH INTEGRATED VENTILATION | CID834DTB4**

**FISHER & PAYKEL**

**INTRODUCTION**

This comprehensive planning guide provides you with the framework and tools to achieve your desired design outcome with Fisher & Paykel appliances. In this guide, you will find a range of conceptual, detailed, and dimensional product information to bring your ideas to life and create spaces that truly reflect your vision.

**SUPPORT**

For additional design planning and installation support please contact the Fisher & Paykel design support team.  
**designsupport@fisherpaykel.com**

**NOTES**

The models shown in this Planning Guide may not be available in all markets and are subject to change at any time. Refer to our website fisherpaykel.com for the latest document version. Product specifications may vary from those shown. This Planning Guide should not be used as installation guidance for any product. Specific installation guidance will be available with the product on delivery and on our website.

**CONTENTS**

**CONCEPT DESIGN PAGE**

**SPECIFICATION GUIDE**

CID834DTB4 **4**

**DATA SHEETS**

Component Overview **7**  
 Cooktop Dimensions **8**  
 Product Clearances **9**  
 Supplied Ducting Overview **10**  
 Cooktop with Supplied Ducting **11**  
 500mm Straight Ducting **12**  
 90 Degree Vertical Elbow **12**  
 15 Degree Bend **13**  
 1m Straight Ducting with Connector **14**  
 90 Degree Horizontal Elbow **15**  
 Duct Adapter, 150mm Diameter **16**  
 Outlet Grille **16**  
 Recirculation Kit **17**

**DEVELOPED AND DETAILED DESIGN PAGE**

**DESIGN CHOICES**

Ventilation Choices **19**  
 Vented Ducting Considerations **20**  
 Recirculated Ducting Considerations **21**  
 Bench Depth **22**  
 Cabinetry Clearances **23**  
 Benchtop Details **24**  
 Overflow Trap **25**

**DEVELOPED AND DETAILED DESIGN PAGE**

## SPECIFICATION GUIDE

**OVERVIEW**

This two-in-one cooktop combines the speed and precision of induction with integrated recirculated extraction. Ideal for island installations or kitchens without external ducting, it eliminates the need for overhead ventilation and allows flexible placement while maintaining a seamless, minimal aesthetic.

**FEATURES**

- ① True design freedom - install flush or raised, ideal for islands and open-plan kitchens
- ② No need for bulky overhead hoods - suitable for high ceilings and flexible kitchen layouts
- ③ Black glass and matte detailing pair seamlessly with other appliances for a cohesive design
- ④ Responsive Touch&Slide controls allow instant, accurate temperature adjustments
- ⑤ Precise control enables fast searing or delicate simmering with ease
- ⑥ Integrated recirculated ventilation with nine speeds and boost for quiet, effective extraction
- ⑦ Induction heats only when cookware is detected, stopping immediately when it's removed
- ⑧ Grease filter tray and glass surface are easy to clean and maintain
- ⑨ Flush ventilation grille allows cookware to move smoothly across the surface
- ⑩ Direct-to-cookware heating improves energy efficiency over traditional gas or electric cooktops

**PRODUCT****CID834DTB4**

83cm Series 9 4 Zone Induction Cooktop with Integrated Ventilation

**SUPPLIED PARTS**

1x 500mm Straight duct 222x89

4x 15° bend 222x89

2x Elbow 90° vertical 222x89

**ACCESSORIES****KRCID834**

Recirculation kit

**FRO-DD**

Replacement Odour Filter (x2 filters)

**DO-G-SS**

Outlet Grille, Stainless Steel

**D1-C-222-89**

Straight Duct 1m and Connector, 222x89

**DA-219-98-150**

Ducting Adaptor, 150mm Diameter

**E90-H-222-89**

Elbow 90° horizontal 222x89

**E90-V-222-89**

Elbow 90° vertical 222x89

The models shown in this Planning Guide may not be available in all markets and are subject to change at any time. Product specifications may vary from those shown. This Planning Guide should not be used as installation guidance for any product. Further information is required to safely and correctly install the products featured here. Specific installation guidance will be available with the product on delivery and on our website [fisherpaykel.com](http://fisherpaykel.com)

**SPECIFICATIONS**

**Model Number**

CID834DTB4 83cm Series 9 4 Zone Induction Cooktop with Integrated Ventilation

**Weight**

Packaged 39 kg

**Electrical**

Supply 220 - 240 V, 50 Hz

Service 34 A

Connection Terminal block

**PRODUCT DIMENSIONS**

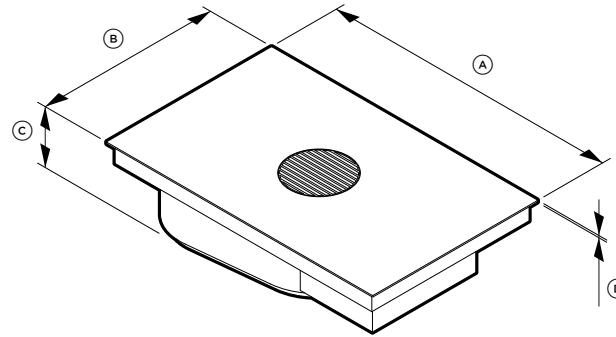

ISOMETRIC VIEW

Product Dimensions	mm
(A) Overall width of cooktop	830
(B) Overall depth of cooktop	515
(C) Overall height of cooktop	218
(D) Height of glass including flange	5.5

**CUTOUT DIMENSIONS**

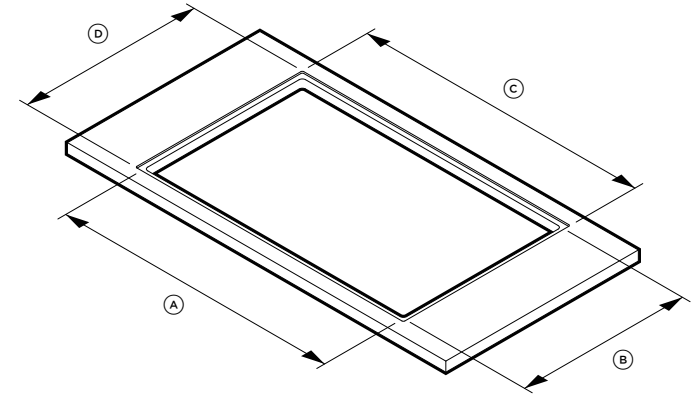

ISOMETRIC VIEW

Product Dimensions	mm
(A) Cutout width	807
(B) Cutout depth	492
(C) Recess width	835
(D) Recess depth	520
(E) Recess height (not shown)	6

The models shown in this Planning Guide may not be available in all markets and are subject to change at any time. Product specifications may vary from those shown. This Planning Guide should not be used as installation guidance for any product. Further information is required to safely and correctly install the products featured here. Specific installation guidance will be available with the product on delivery and on our website fisherpaykel.com

## DATA SHEETS

SUPPLIED COMPONENTS

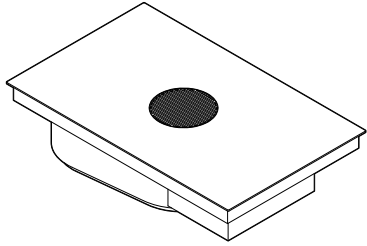

INDUCTION COOKTOP WITH INTEGRATED VENTILATION

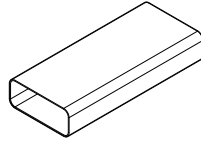

500MM STRAIGHT DUCTING

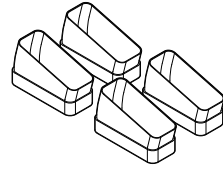

15° BEND

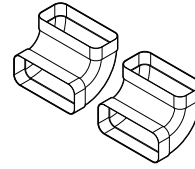

90° VERTICAL ELBOW

OPTIONAL ACCESSORIES

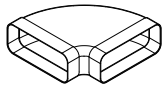

90° HORIZONTAL ELBOW

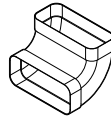

90° VERTICAL ELBOW

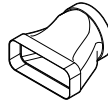

DUCT ADAPTER, 150MM DIAMETER

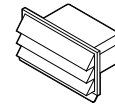

STAINLESS STEEL OUTLET GRILLE

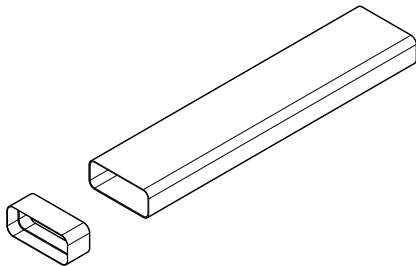

1M STRAIGHT DUCTING 218 X 55  
+  
CONNECTOR 218 X 55

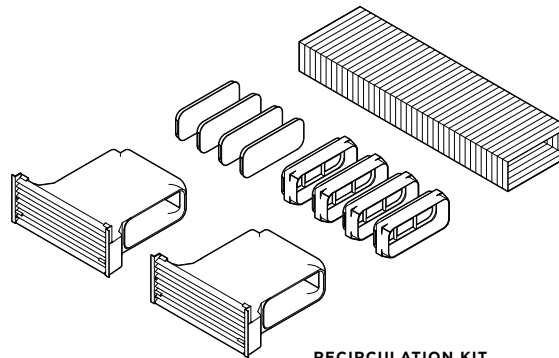

RECIRCULATION KIT

Model no:

CID834DTB4

83cm Series 9 4 Zone Induction Cooktop with Integrated Ventilation

Supplied Components

Quantity

Induction Cooktop with Integrated Ventilation	1
500mm Straight Ducting	1
15° Bend	4
90° Vertical Elbow	2

IMPORTANT:

DO NOT ENCASE DUCTING COMPONENTS IN CONCRETE

Optional accessories can be purchased separately to expand venting options.

Optional Accessories

Model no.

90° Horizontal Elbow	E90-H-222-89
90° Vertical Elbow	E90-V-222-89
Duct Adapter, 150mm Diameter	DA-219-98-150
Outlet Grille, Stainless Steel	DO-G-SS
1M Straight Ducting 218 x 55	DI-C-218-55
Connector 218 x 55	
Recirculation Kit	KRCID834
• x2 Filter Box Assembly	
• x2 Odour Filter (not shown)	
• x4 Duct Adapter	
• x4 Cap	
• 3m Flexible Ducting	
Replacement Odour Filter (not shown, x2 filters)	FRO-DD

The models shown in this Planning Guide may not be available in all markets and are subject to change at any time. Product specifications may vary from those shown. This Planning Guide should not be used as installation guidance for any product. Further information is required to safely and correctly install the products featured here. Specific installation guidance will be available with the product on delivery and on our website fisherpaykel.com

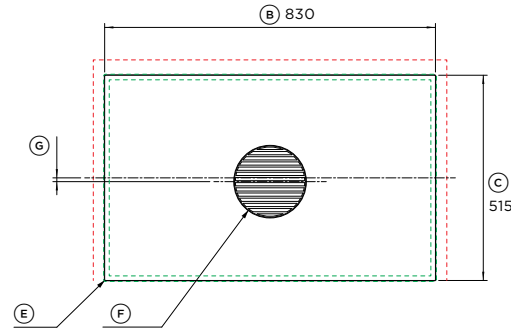

PLAN VIEW

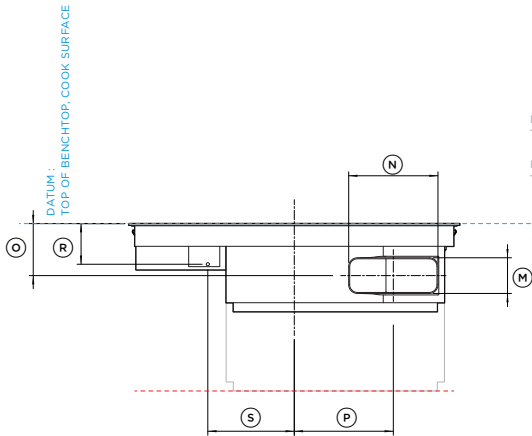

BACK VIEW

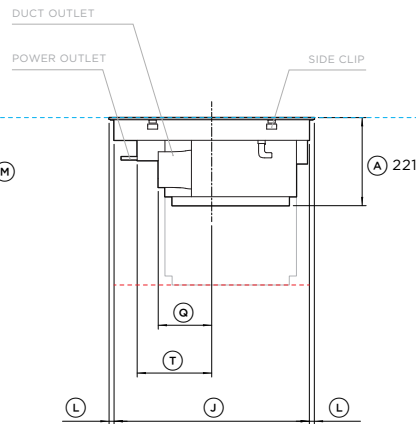

PROFILE VIEW

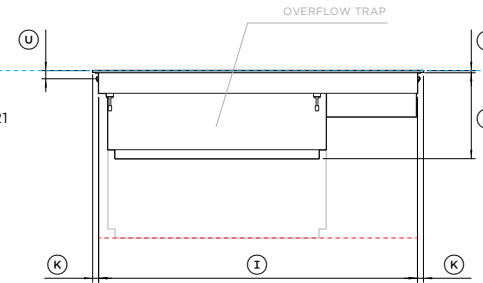

FRONT VIEW

**Model no:**

**CID834DTB4** 83cm Series 9 4 Zone Induction Cooktop with Integrated Ventilation

Product Dimensions	mm
A Overall height of cooktop	221
B Overall width of cooktop	830
C Overall depth of cooktop	515
D Height of cooktop glass (includes chassis flange)	5.5
E Corner radii of glass	2
F Diameter of extractor cover	179
G Offset of extractor forward from centre of cooktop	10
H Height of chassis	215
I Width of chassis	799
J Depth of chassis	488
K Width of glass overhang at side of chassis	15
L Depth of glass overhang at front and rear of chassis	13
M Height of duct outlet	89
N Width of duct outlet	222
O Height from top of cooktop to centre of duct outlet	131
P Width from centre of cooktop to centre of duct outlet	249
Q Depth from centre of cooktop to duct outlet	134
R Height from top of cooktop to power outlet	102
S Width from centre of cooktop to power outlet	217
T Depth from centre of cooktop to power outlet	187
U Distance from top of cooktop to clip friction surface	21

----- INDICATES CABINETRY / PRODUCT DATUM  
 - - - - - INDICATES CABINETRY CLEARANCES  
 - · - · - INDICATES CUTOUT

IMPORTANT NOTE: Throughout this guide, dimensions may vary by ±2mm (1/16"). Please read the installation manual for detailed information on installing the product. For full installation instructions & specifications visit [fisherpaykel.com](http://fisherpaykel.com)



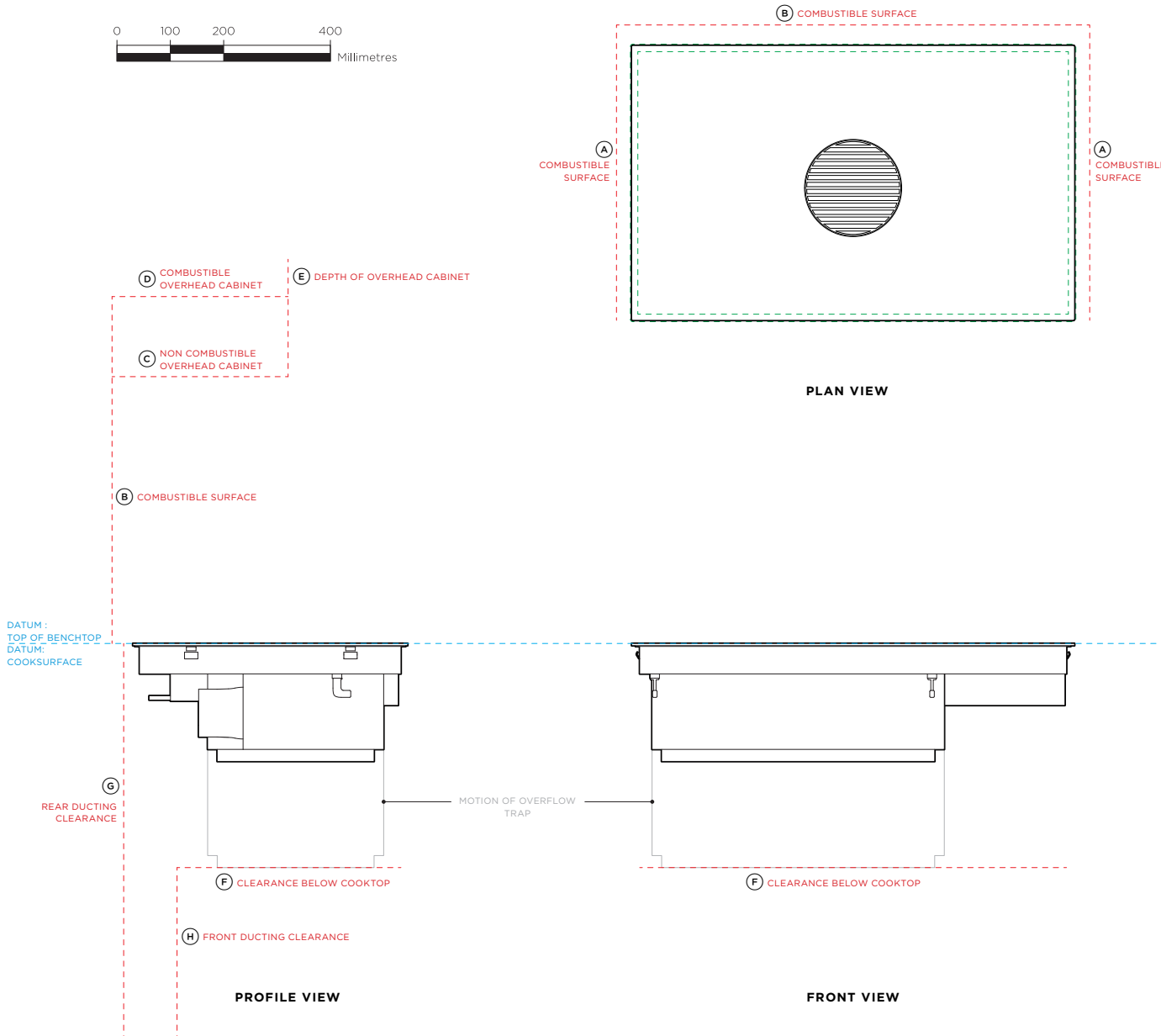

**Model no:**

**CID834DTB4**

83cm Series 9 4 Zone Induction Cooktop with Integrated Ventilation

**Product Clearances**

**mm**

A	Minimum clearance from nearest combustible surface to - side edge of cutout	40
	- side edge of glass	30
B	Minimum clearance from nearest combustible surface to - rear edge of cutout	50
	- rear edge of glass	39
	- front edge of glass	554
C	Minimum clearance from top of cook surface to non combustible surface directly above cooktop	500
D	Minimum clearance from top of cook surface to combustible surface directly above cooktop	650
E	Maximum depth of overhead cabinetry	330
F	Minimum clearance below cook surface to top of any appliance or obstruction below cooktop (required for cleaning access)	421
G	Rear ducting clearance from - rear edge of cutout*	31
	- rear edge of glass	20
	- front edge of glass*	535
H	Minimum distance** from front ducting clearance to rear ducting clearance	105

\* For ducting routed down, where a 90° Vertical Elbow is connected to the duct outlet. Depth can be increased by use of connector and ducting. See following pages for more details.

\*\* For ducting scenarios not routed through kick cavity, or when ducting is routed through 150mm kick height cavity. Refer following pages for more details.

**Ventilation Requirements**

**cm<sup>2</sup>**

Minimum ventilation gap at front of cooktop - Height of gap along full length of chassis	5
- or equivalent area	42cm <sup>2</sup>
Minimum ventilation gap at rear of cooktop	40cm <sup>2</sup>

IMPORTANT NOTE: Throughout this guide, dimensions may vary by ±2mm (1/16"). Please read the installation manual for detailed information on installing the product. For full installation instructions & specifications visit [fisherpaykel.com](http://fisherpaykel.com)

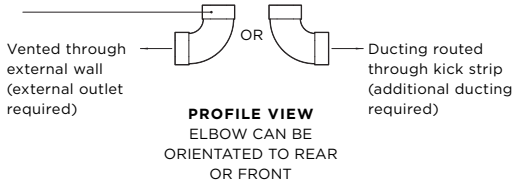
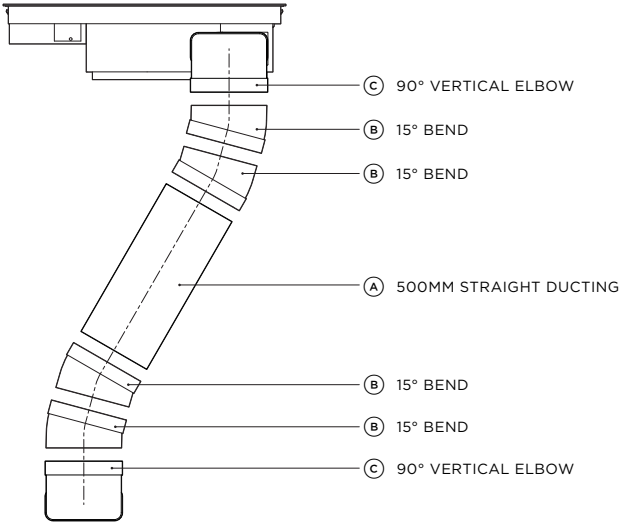
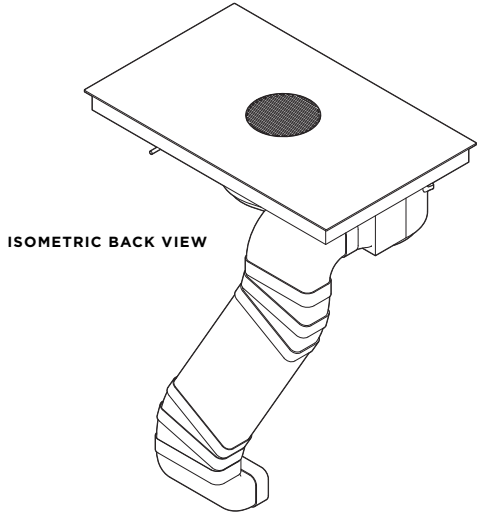

**Model no:**  
**CID834DTB4** 83cm Series 9 4 Zone Induction Cooktop with Integrated Ventilation

Supplied Ducting Components	Quantity
500mm Straight Ducting	1
15° Bend	4
90° Vertical Elbow	2

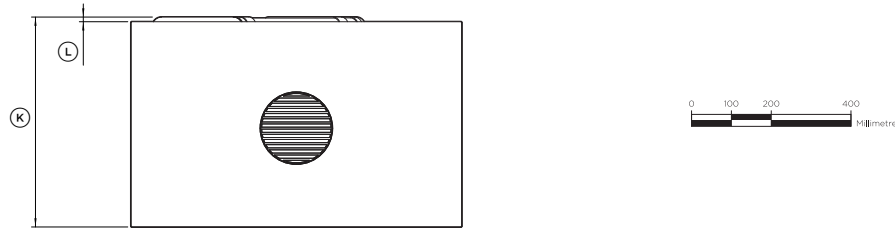

PLAN VIEW

DATUM: TOP OF BENCHTOP, COOK SURFACE

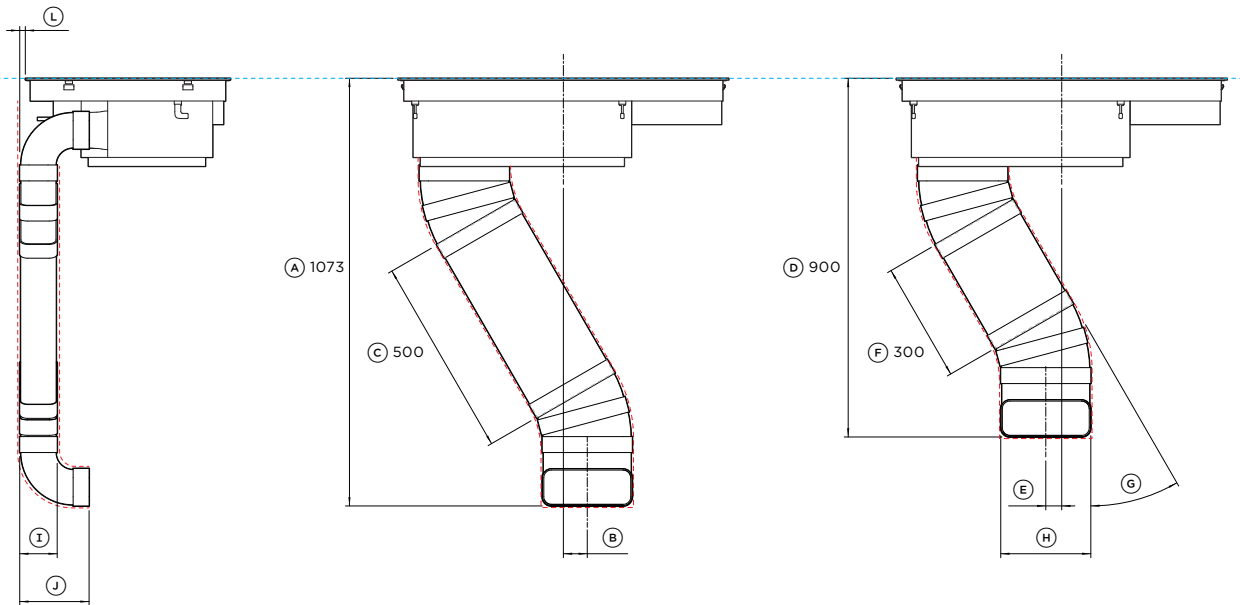

PROFILE VIEW  
MAXIMUM HEIGHT OF SUPPLIED DUCTING

FRONT VIEW  
MAXIMUM HEIGHT OF SUPPLIED DUCTING

FRONT VIEW  
SUPPLIED DUCTING TRIMMED FOR 900 HIGH BENCHTOP

**Model no:**  
**CID834DTB4** 83cm Series 9 4 Zone Induction Cooktop with Integrated Ventilation

**Shown with:**  
1x supplied 500mm Straight Ducting  
4x supplied 15° Bend  
2x supplied 90° Vertical Elbow

Product Dimensions	mm
(A) Maximum height of cooktop and supplied ducting	1073
(B) Offset from centre of duct outlet at maximum height	60
(C) Length of straight ducting at maximum height	500
(D) Overall height for 900 bench height (cooktop flush)	900
(E) Offset from centre of duct outlet at 900mm overall height	40
(F) Length of trimmed straight ducting for 900mm overall height	300
(G) Angle of ducting	30°
(H) Width of ducting	226
(I) Depth of straight ducting and 15 degree bend	94
(J) Overall depth of ducting	174
(K) Overall depth of cooktop and ducting	529
(L) Depth from rear of cooktop to rear of ducting	14

Clearance Dimensions for Ducting	mm
Clearance parallel to width of ducting	232
Clearance parallel to depth of ducting	105

----- INDICATES CABINETRY / PRODUCT DATUM  
 - - - - - INDICATES CABINETRY CLEARANCES  
 - · - · - INDICATES CUTOUT

IMPORTANT NOTE: Throughout this guide, dimensions may vary by ±2mm (1/16"). Please read the installation manual for detailed information on installing the product. For full installation instructions & specifications visit [fisherpaykel.com](http://fisherpaykel.com)

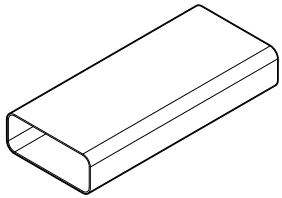

500MM STRAIGHT DUCTING 222 X 89

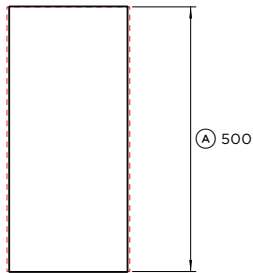

PLAN VIEW

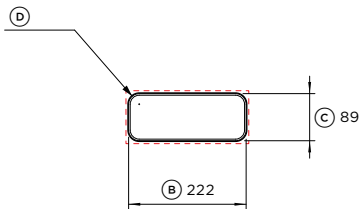

FRONT VIEW

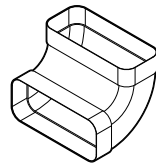

90° VERTICAL ELBOW

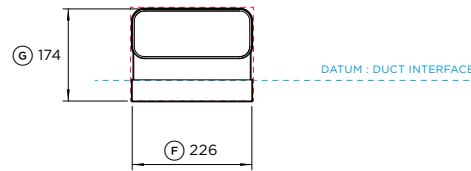

PLAN VIEW

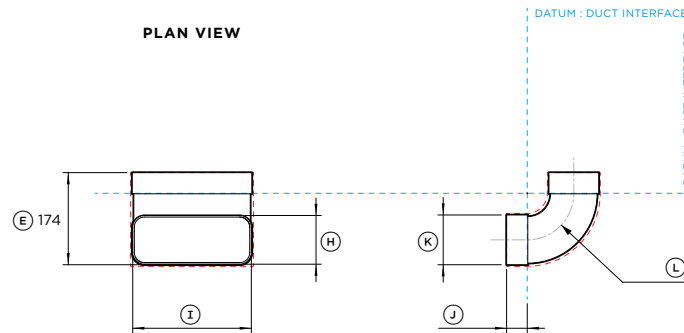

FRONT VIEW

PROFILE VIEW

**Model no:**

**CID834DTB4** 83cm Series 9 4 Zone Induction Cooktop with Integrated Ventilation, Recirculated

**Parts Shown:**

Supplied x1 500mm Straight Ducting 222 x 89  
 Supplied x2 90° Vertical Elbow\*  
 \* E90-V-222-89 as optional accessory

**500MM STRAIGHT DUCTING 222 X 89**

Product Dimensions	mm
(A) Overall length of ducting	500
(B) Overall width of ducting	222
(C) Overall depth of ducting	89
(D) Corner radii of ducting	20

Clearance Dimensions	mm
Height	100
Width	232

**90° VERTICAL ELBOW**

Product Dimensions	mm
(E) Overall height of elbow	174
(F) Overall width of elbow	226
(G) Overall depth of elbow	174
(H) Internal height of female duct end	92
(I) Internal width of female duct end	224
(J) Internal shoulder depth of female duct end	39
(K) External height of female duct end	94
(L) Centre radius of bend	88

Clearance Dimensions	mm
Height	100
Width	232
Depth	100
Internal radius	38
External radius	138

----- INDICATES CABINERY / PRODUCT DATUM  
 - - - - - INDICATES CABINERY CLEARANCES  
 - · - · - INDICATES CUTOUT

IMPORTANT NOTE: Throughout this guide, dimensions may vary by ±2mm (1/16"). Please read the installation manual for detailed information on installing the product. For full installation instructions & specifications visit [fisherpaykel.com](http://fisherpaykel.com)

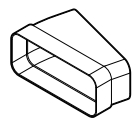

15° DEGREE BEND

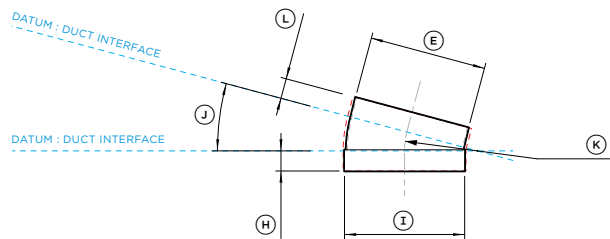

PLAN VIEW

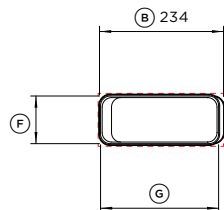

FRONT VIEW

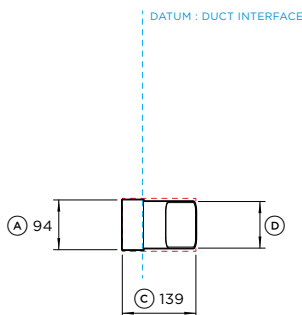

PROFILE VIEW

**Model no:**

**CID834DTB4** 83cm Series 9 4 Zone Induction Cooktop with Integrated Ventilation

**Part Shown:**

Supplied x4 15 Degree Bend

**Product Dimensions**

	mm
(A) Overall height of ducting	94
(B) Overall width of ducting	234
(C) Overall depth of ducting	139
(D) Height of male duct end	88
(E) Width of male duct end	221
(F) Internal height of female duct end	90
(G) Internal width of female duct end	223
(H) Internal shoulder depth of female duct end	38
(I) External width of female duct end	227
(J) Angle of bend	15°
(K) Centre radius of bend	137
(L) Insertion depth of male duct end	38

**Clearance Dimensions**

	mm
Height	100
Width	232
Depth	100
Internal radius	38
External radius	138

----- INDICATES CABINERY / PRODUCT DATUM  
 - - - - - INDICATES CABINERY CLEARANCES  
 - · - · - INDICATES CUTOUT

IMPORTANT NOTE: Throughout this guide, dimensions may vary by ±2mm (1/16"). Please read the installation manual for detailed information on installing the product. For full installation instructions & specifications visit [fisherpaykel.com](http://fisherpaykel.com)

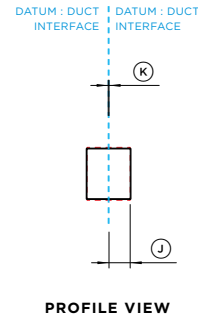
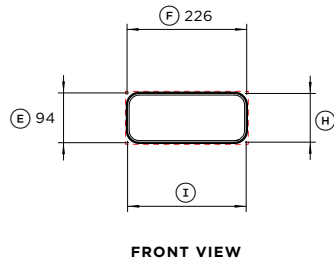
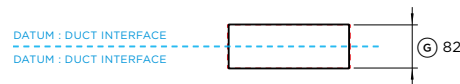
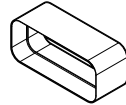
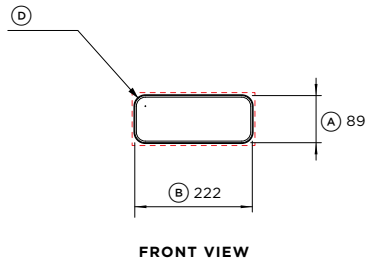
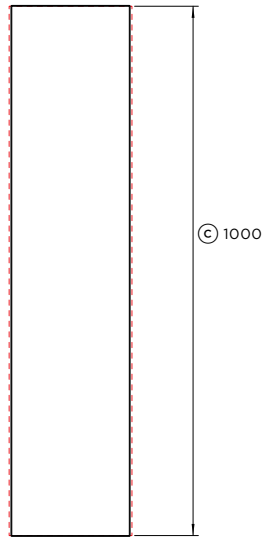
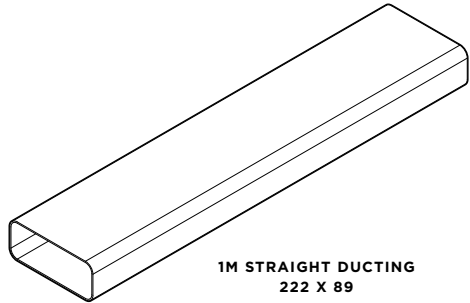

**Optional Part No:**

D1-C-222-89 1M Straight Ducting 222 x 89  
Connector 222 x 89

**1M STRAIGHT DUCTING 222 X 89**

Product Dimensions		mm
(A)	Overall height of ducting	89
(B)	Overall width of ducting	222
(C)	Overall length of ducting	1000
(D)	Corner radii of ducting	20

Clearance Dimensions		mm
	Height	100
	Width	232

**CONNECTOR 222 X 89**

Product Dimensions		mm
(E)	Overall height of connector	94
(F)	Overall width of connector	226
(G)	Overall depth of connector	82
(H)	Internal height of connector	92
(I)	Internal width of connector	224
(J)	Internal depth to shoulder	40
(K)	Thickness of internal shoulder divider	2

Clearance Dimensions		mm
	Height	100
	Width	232

----- INDICATES CABINETRY / PRODUCT DATUM  
 - - - - - INDICATES CABINETRY CLEARANCES  
 - · - · - INDICATES CUTOUT

IMPORTANT NOTE: Throughout this guide, dimensions may vary by ±2mm (1/16"). Please read the installation manual for detailed information on installing the product. For full installation instructions & specifications visit [fisherpaykel.com](http://fisherpaykel.com)

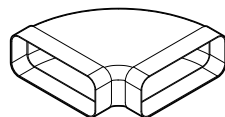

90° HORIZONTAL ELBOW

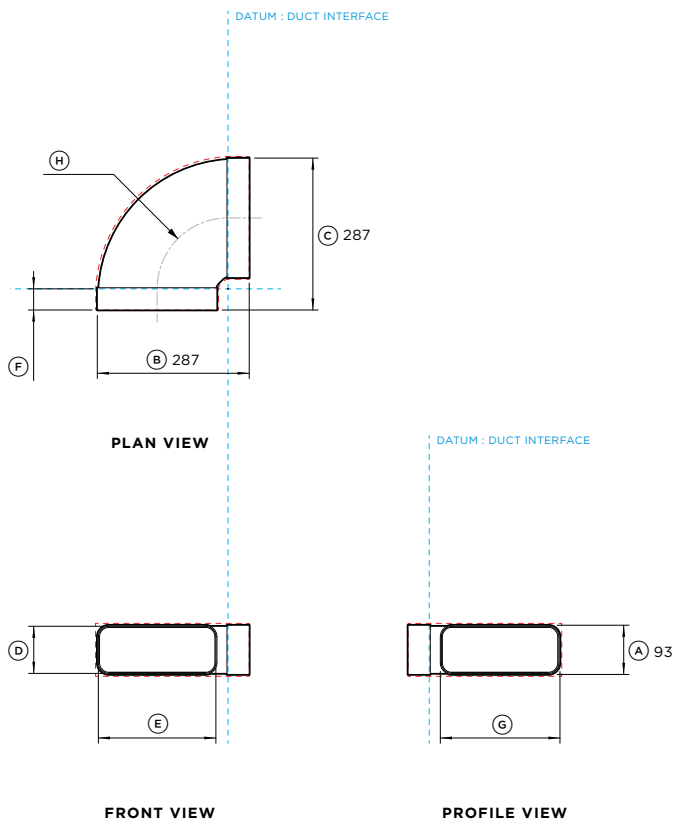

Optional Accessory no:

E90-H-222-89 90° Horizontal Elbow

Product Dimensions

	mm
(A) Overall height of duct	93
(B) Overall width of duct	287
(C) Overall length of duct	287
(D) Internal height of female duct end	89
(E) Internal width of female duct end	222
(F) Internal shoulder depth of female duct end	40
(G) External width of female duct end	226
(H) Centre Radius of bend	134

Clearance Dimensions

	mm
Height	100
Width	232
External radius	267

IMPORTANT NOTE: Throughout this guide, dimensions may vary by ±2mm (1/16"). Please read the installation manual for detailed information on installing the product. For full installation instructions & specifications visit [fisherpaykel.com](http://fisherpaykel.com)

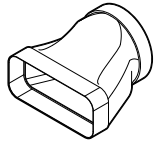

ADAPTER

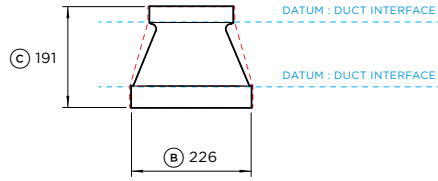

PLAN VIEW

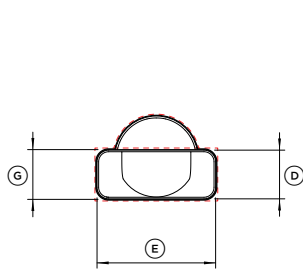
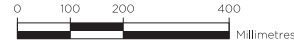

FRONT VIEW

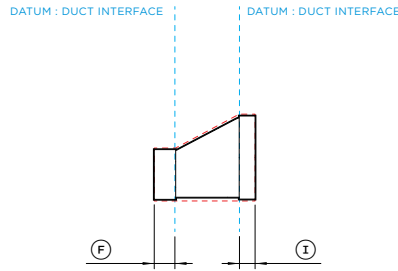

PROFILE VIEW

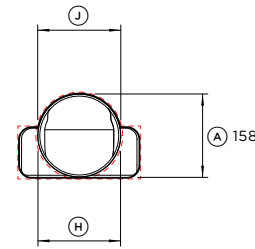

BACK VIEW

Optional Accessory no:

DA-219-98-150 Duct Adapter, 150mm Diameter

Product Dimensions

	mm
(A) Overall height of adapter	158
(B) Overall width of adapter	226
(C) Overall length of adapter	191
(D) Internal height of rectangular female duct end	92
(E) Internal width of rectangular female duct end	224
(F) Internal depth of rectangular female duct end	39
(G) External height of rectangular female duct end	94
(H) Internal diameter of round female duct end	156
(I) Internal depth of round female duct end	30
(J) External diameter of round duct female duct end	158

Optional Accessory no:

DO-G-SS Outlet Grille, Stainless Steel

Product Dimensions

	mm
(A) Overall height of grille	160
(B) Overall width of grille	290
(C) Overall depth of grille	163
(D) Height of male duct end	83
(E) Width of male duct end	215
(F) Length of male duct end	120
(G) Corner radii of male duct end	16
(H) Height from top of spigot to top of frame	32
(I) Height of external frame	150
(J) Depth of external frame	15
(K) Depth of external frame and grille	43
(L) Height of louvres	120
(M) Width of louvres	260

----- INDICATES CABINETRY / PRODUCT DATUM  
 - - - - - INDICATES CABINETRY CLEARANCES  
 - · - · - INDICATES CUTOUT

IMPORTANT NOTE: Throughout this guide, dimensions may vary by ±2mm (1/16"). Please read the installation manual for detailed information on installing the product. For full installation instructions & specifications visit [fisherpaykel.com](http://fisherpaykel.com)

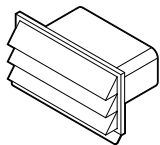

OUTLET GRILLE, STAINLESS STEEL

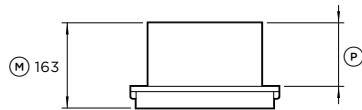

PLAN VIEW

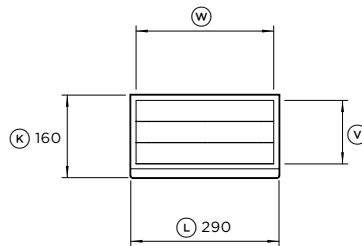

FRONT VIEW

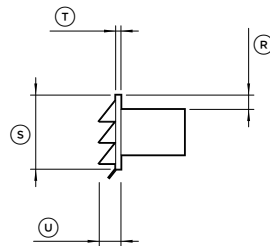

PROFILE VIEW

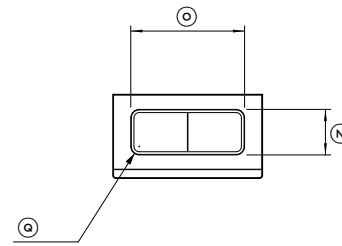

BACK VIEW

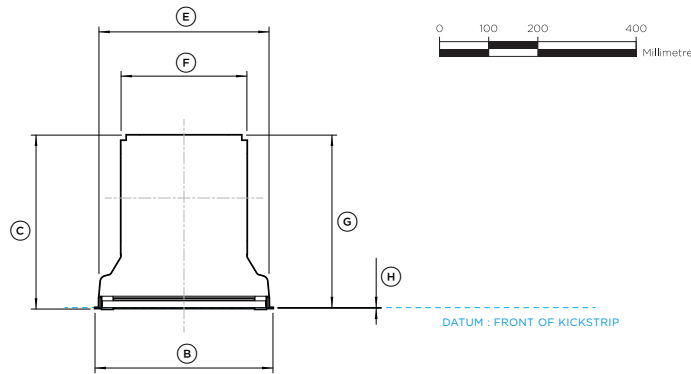
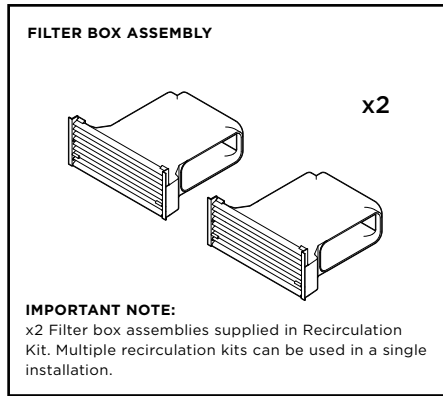

PLAN VIEW

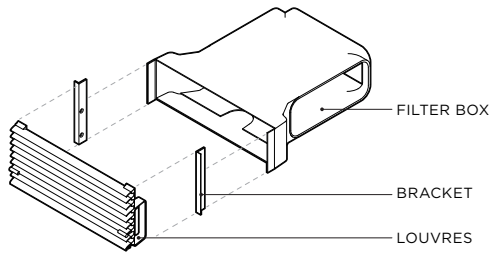

EXPLODED ISOMETRIC VIEW

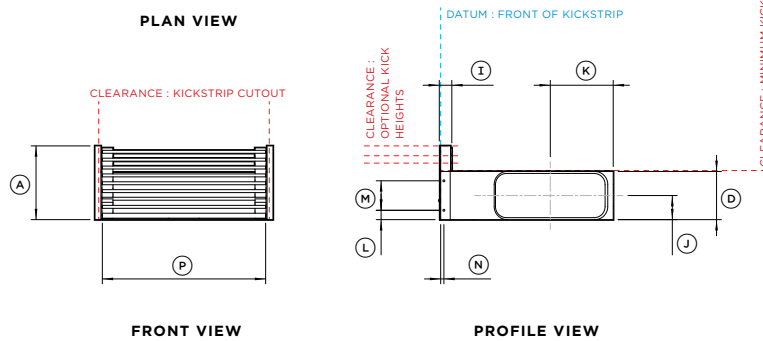

FRONT VIEW

PROFILE VIEW

**Optional Accessory no:**

- KRCID834** Recirculation Kit  
 - x2 Filter box assembly  
 - x4 Cap  
 - x4 Duct adapter  
 - 3m Flexible ducting 227x94

**Product Dimensions**

	mm
(A) Overall height of filter box assembly (louvres can be trimmed to suit kickstrip)	150/130/ 115/100
(B) Overall width of filter box assembly	362
(C) Overall depth of filter box assembly	354
(D) Height of filter box	98
(E) Width of filter box at front	346
(F) Width of filter box at rear	256
(G) Depth of filter box (excludes bracket)	351
(H) Depth of bracket flange	1
(I) Depth of bracket and louvres	26
(J) Height from bottom of filter box to centre of outlets	49
(K) Depth from rear of filter box to centre of side outlets	128
(L) Height from bottom of bracket to lower hole centre	19
(M) Height between hole centres	60
(N) Depth from rear of bracket flange to hole centre	7
(O) Hole diameter	4
(P) Width of louvres	332
(Q) Distance from edge of duct adapter to edge of filter box	46
(R) Internal depth of female end of duct adapter	43
(S) Overall length of duct adapter	227
(T) Internal length of female end of duct adapter	223
(U) Overall height of duct adapter (not shown)	94
(V) Internal height of female end of duct adapter (not shown)	90
(W) Thickness of cap from edge of filter box	2
(X) Length of cap	226
(Y) Height of cap (not shown)	93

**FILTER BOX ASSEMBLY WITH DUCT ADAPTER AND CAPS - X2 SETS SUPPLIED**

Position of caps and adapters can be interchanged to suit ducting layout

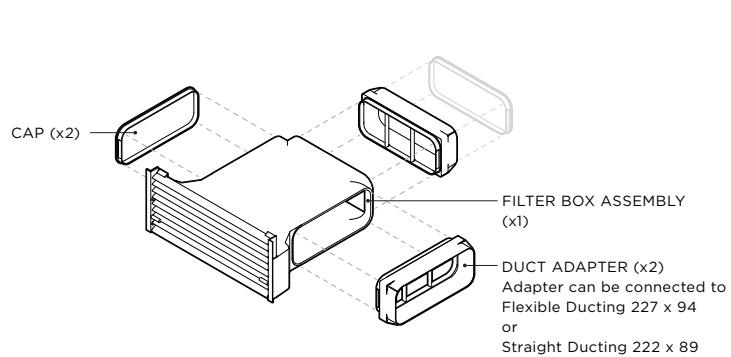

EXPLODED ISOMETRIC VIEW

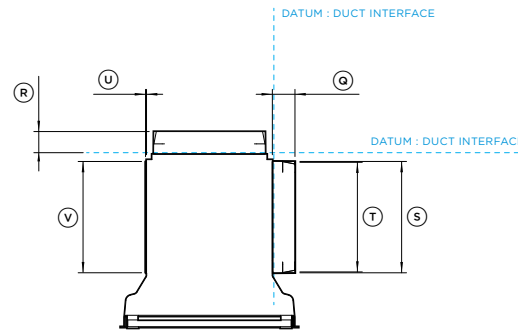

PLAN VIEW

**Kickstrip Dimensions**

	mm
Height of kickstrip (louvres trimmed to suit)	150 / 130 / 115 / 100
Overall width of cutout	347

- INDICATES CABINETRY / PRODUCT DATUM
- INDICATES CABINETRY CLEARANCES
- INDICATES CUTOUT

**IMPORTANT NOTE:** Throughout this guide, dimensions may vary by ±2mm (1/16"). Please read the installation manual for detailed information on installing the product. For full installation instructions & specifications visit [fisherpaykel.com](http://fisherpaykel.com)

## DESIGN CHOICES

POSITION WALL DUCTING TERMINATION INSTALLATION

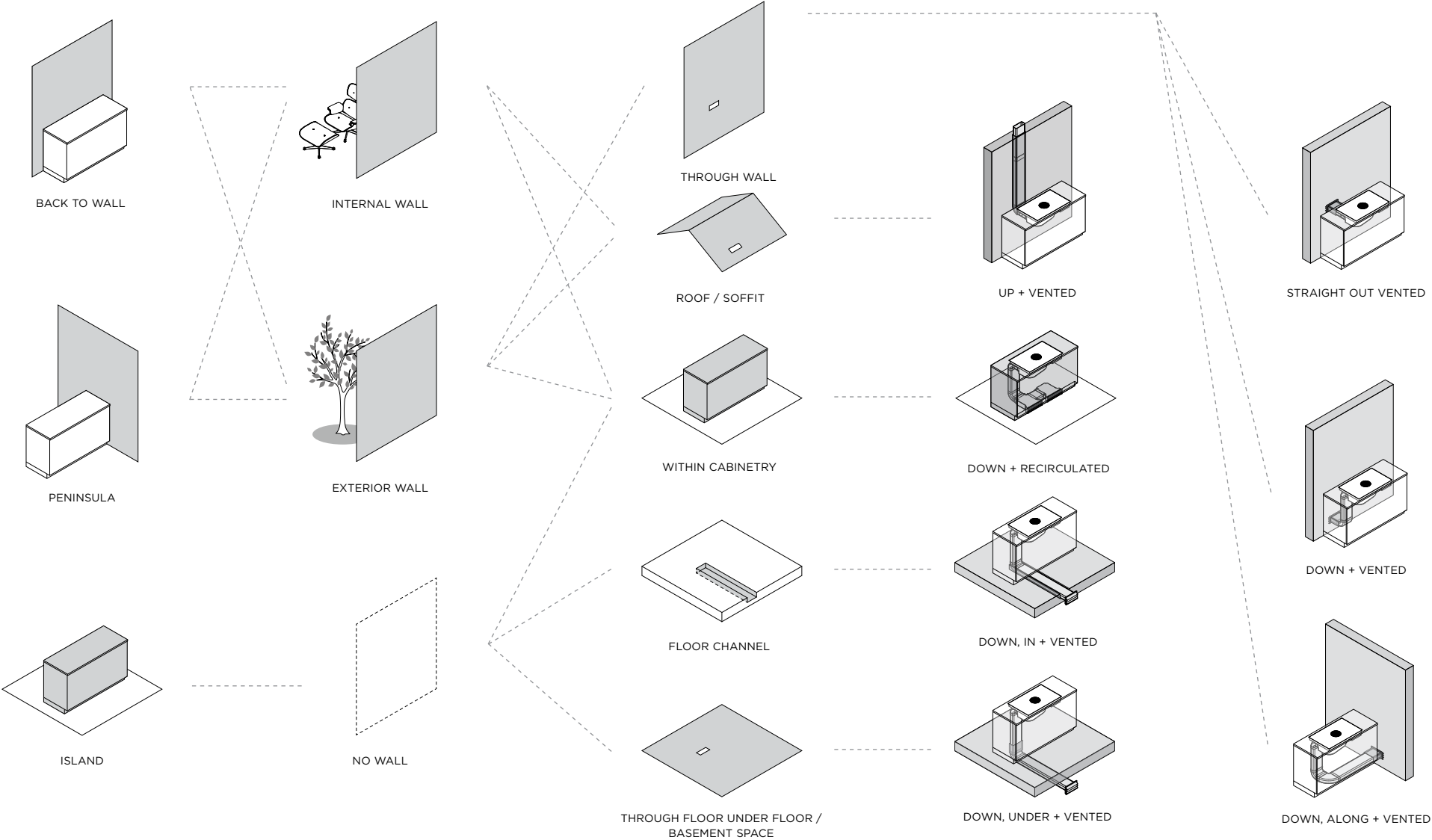

**PLEASE NOTE:**

These are representational illustrations of cabinetry to show ducting options and provide guideline minimum benchtop depths. Benchtop depths are driven by ducting depth requirements within the cabinetry. Refer page 'Bench Depth Overview - Duct Down' for cabinetry overview and generic cabinetry dimensions used for these examples.

Benchtop dimensions and cabinetry design should be adapted to suit requirements specific to location, materials and construction methods.

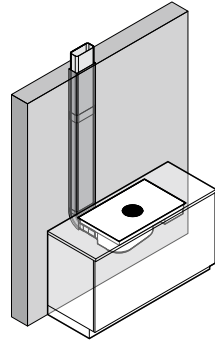

**UP + VENTED**

- Minimal impact on cabinetry
- Optimised cabinetry
- Full depth under bench storage
- Decreased extraction performance due to venting upwards
- 105mm D x 235mm W cavity required in wall to route ducting

Back to Wall

600mm\*

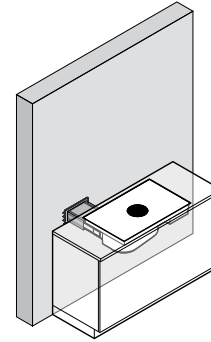

**STRAIGHT OUT VENTED**

- Minimal impact on cabinetry
- Optimised cabinetry
- Full depth under bench storage
- Best extraction performance of all setups
- Height of outlet determined by cooktop
- Visual impact of vent location

Back to Wall

600mm\*

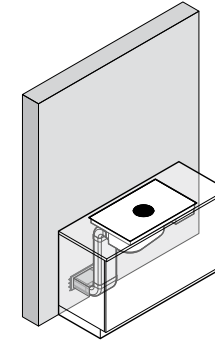

**DOWN + VENTED**

- No minimum kick height
- Height of external outlet adaptable to requirements
- 105mm deep space required down back of cabinet
- Reduced under bench storage depth

Back to Wall

600mm\*

ADVANTAGES

CONSIDERATIONS

BENCH TYPE

MIN BENCH DEPTH\*

\* Refer to page 'Bench Depth' for generic benchtop and cabinetry dimensions  
 \*\* Dimensions relational, refer page 'Cabinetry Clearances' for details

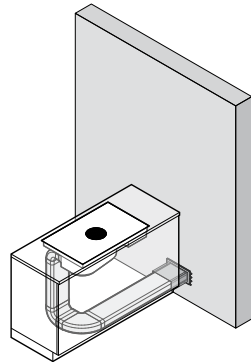

**THRU BASE - DOWN, ALONG + VENTED**

- Confined to cabinetry
- Discreet vent outlet height
- 105mm deep space required down back of cabinet \*\*
- Reduced under bench storage depth
- 100mm minimum toe kick height \*\*
- Cabinetry feet may need relocating

Peninsula - left or right

600mm\*

ADVANTAGES

CONSIDERATIONS

BENCH TYPE

MIN BENCH DEPTH\*

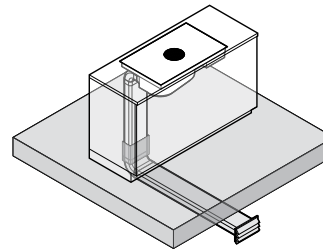

**THRU FLOOR - DOWN, UNDER + VENTED**

- Multi-directional - left, right, front, back
- Allows for Island Bench duct out
- No minimum kick height
- 105mm depth space required down back of cabinet
- Reduced under bench storage depth
- Below floor access required
- Any flooring type

Island, Peninsula, Back to Wall

600mm\*

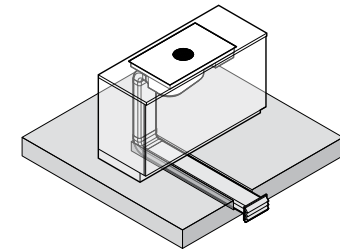

**IN FLOOR - DOWN, IN + VENTED**

- Multi-directional - left, right, front, back
- Allows for Island Bench duct out
- No minimum kick height
- 105mm depth space required down back of cabinet
- Reduced under bench storage depth
- Channel required in floor (DO NOT encase F&P parts in concrete)
- Flooring must be able to cover channel - tiles, timber

Island, Peninsula, Back to Wall

600mm\*

**PLEASE NOTE:**

These are representational illustrations of cabinetry to show ducting options and provide guideline minimum benchtop depths. Benchtop depths are driven by ducting depth requirements within the cabinetry. Benchtop dimensions and cabinetry design should be adapted to suit requirements specific to location, materials and construction methods.

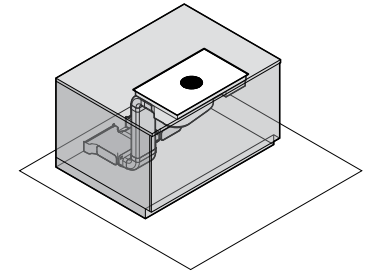
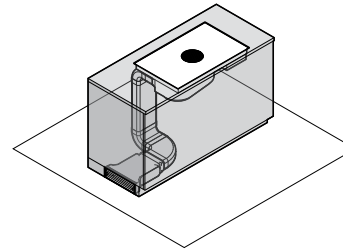
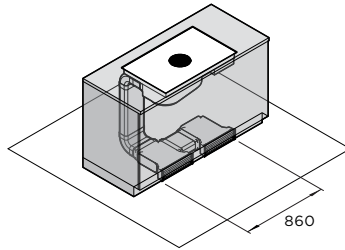

**ADVANTAGES**

**DOWN, RECIRCULATION OUTLET TO FRONT**

- Compact - fits in 900 width cabinet
- No construction allowances required outside cabinetry
- x2 filter boxes provide greater extraction pressure than x1

**DOWN, RECIRCULATION TO SIDE**

- Ducting contained to cabinetry
- No construction allowances required outside cabinetry
- Vents away from feet at work spaces

**DOWN, RECIRCULATION TO REAR**

- Ducting contained to cabinetry
- No construction allowances required outside cabinetry
- Vents away from feet at work spaces

**CONSIDERATIONS**

- 105mm depth space required down back of cabinet \*\*
- Reduced under bench storage depth
- 100mm minimum toe kick height \*\*
- Requires deeper bench top - 685mm minimum depth
- Recirculation filters reduce airspeed compared to vented
- Recirculation outlet is at a persons foot height
- Outlet vent located at feet when using cooktop
- x2 Filters requires cleaning 6-12 monthly
- Cabinetry feet may need relocating

- 105mm depth space required down back of cabinet \*\*
- Reduced under bench storage depth
- 100mm minimum toe kick height \*\*
- Requires deeper bench top - 685mm minimum depth
- Recirculation filters reduce airspeed compared to vented
- Recirculation outlet potentially located below other workspaces
- x1 filter provides less extraction pressure than x2 filters
- x1 filter requires cleaning 3-6 monthly
- Cabinetry feet may need relocating
- Can be routed to the left or right

- 105mm depth space required within cabinets \*\*
- Recirculation outlets may be visible from adjacent living spaces
- 100mm minimum toe kick height \*\*
- Requires deeper bench top - 1050mm minimum depth
- x2 filter boxes provide greater extraction pressure than x1
- Recirculation filters reduce airspeed compared to vented
- x2 filters requires cleaning 6-12 monthly
- Cabinetry feet may need relocating

**BENCH TYPE**

Peninsula, Island, Back to Wall

Peninsula, Island, Back to Wall

Peninsula, Island

**MIN BENCH DEPTH\***

685mm

685mm

1050mm

\* Refer to page 'Bench Depth' for generic benchtop and cabinetry dimensions

\*\* Dimensions relational, refer page 'Cabinetry Clearances' for details

**IMPORTANT NOTE:**

These are representational illustrations of cabinetry to provide guideline minimum benchtop depths. Benchtop depths are driven by clearance requirements above bench and ducting depth requirements within the cabinetry. Benchtop and cabinetry dimensions should be adapted to suit requirements specific to location, materials and construction methods.

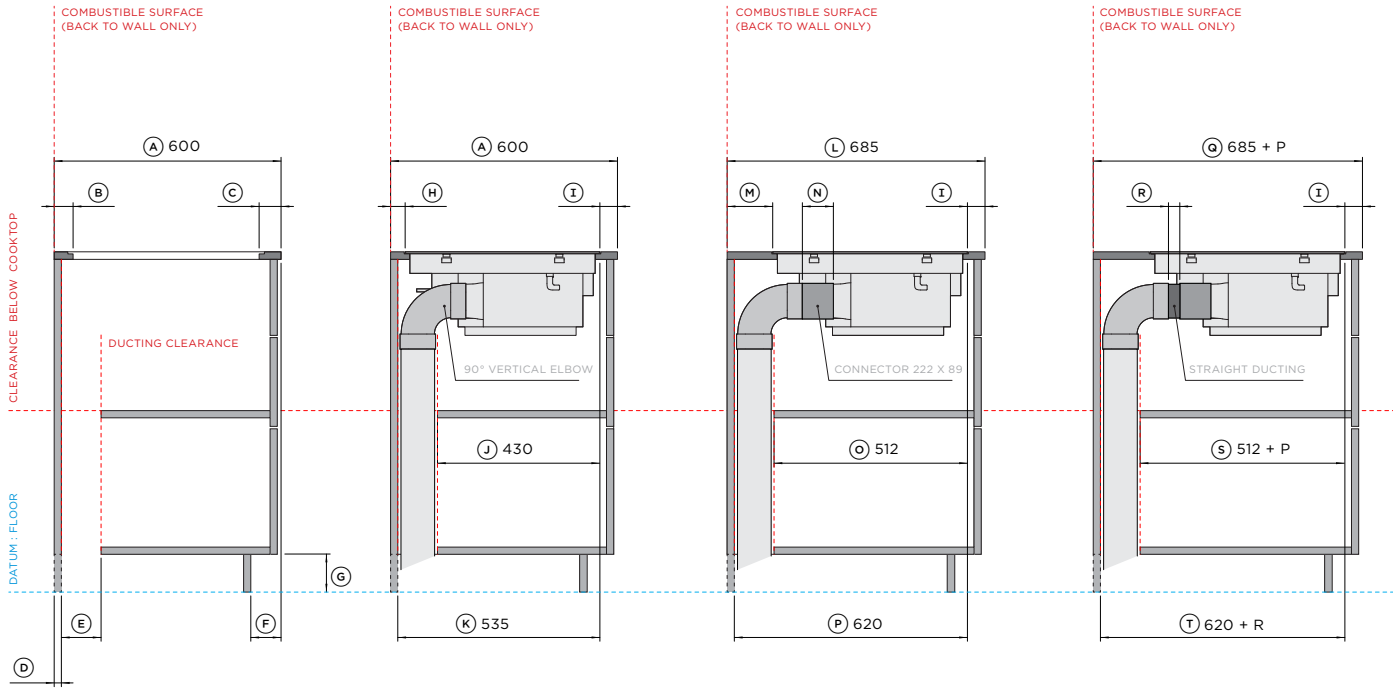
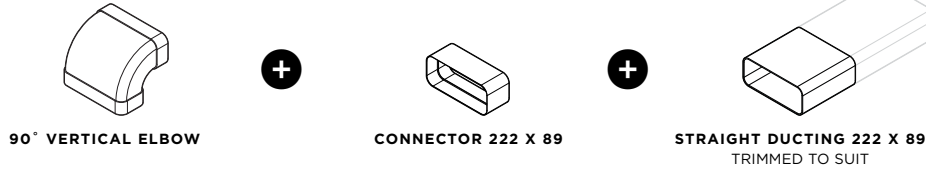

**PROFILE VIEW**  
CABINETRY OVERVIEW

**PROFILE VIEW**  
COOKTOP DUCT DOWN

**PROFILE VIEW**  
COOKTOP DUCT DOWN  
WITH  
CONNECTOR

**PROFILE VIEW**  
COOKTOP DUCT DOWN  
WITH  
CONNECTOR +  
STRAIGHT DUCTING

**Model no:**

**CID834DTB4** 83cm Series 9 4 Zone Induction Cooktop with Integrated Ventilation

**Cabinetry Dimensions**

	<b>mm</b>
(A) Minimum recommended bench depth	600
(B) Minimum clearance to combustible surface from rear of cutout	50
(C) Resulting distance from front of cutout to front of benchtop*	58
(D) Thickness of rear panel	19
(E) Minimum clearance at rear of cabinet for ducting** †	105
(F) Distance from front of benchtop to front of kickstrip	80
(G) Minimum height of kickstrip to accommodate ducting*** †	100
(H) Minimum clearance to combustible surface from rear of glass	39
(I) Resulting distance from front of glass to front of benchtop*	46
(J) Distance from front of glass to ducting clearance	430
(K) Distance from front of glass to rear of cavity	535
(L) Minimum bench depth with connector ****	685
(M) Resulting distance from rear of glass to rear of benchtop to accommodate under bench clearance for ducting.	124
(N) Depth of connector	82
(O) Distance from front of glass to ducting clearance	512
(P) Distance from front of glass to rear of cavity	620
(Q) Minimum bench depth with connector and straight ducting ****	685 + (P)
(R) Length of exposed straight ducting (trimmed to suit cabinetry)	> 1
(S) Distance from front of glass to ducting clearance	512 + (R)
(T) Distance from front of glass to rear of cavity	620 + (R)

\* Dimension based on 600 benchtop, driven by rear clearance requirements. Can be decreased/increased to suit aesthetic, materials and construction.  
 † Minimum rear ducting clearance is relational to minimum kick height in scenarios where ducting is runs within the kick strip. Refer to page 'Cabinetry Scenarios' for further detail.  
 \*\* Applicable to drawers, shelves or a false back. Not required for 'Up + Out' and 'Straight Out' ducting scenarios.  
 \*\*\* No minimum height for 'Straight Out', 'Down + Out', 'Thru Floor' and 'In Floor' ducting scenarios.  
 \*\*\*\* Depth based on generic measurements (C) and (I)\* which can be increased/decreased to suit aesthetic and/or material requirements.

----- INDICATES CABINETRY / PRODUCT DATUM  
 - - - - - INDICATES CABINETRY CLEARANCES  
 - · - · - INDICATES CUTOUT

IMPORTANT NOTE: Throughout this guide, dimensions may vary by ±2mm (1/16"). Please read the installation manual for detailed information on installing the product. For full installation instructions & specifications visit [fisherpaykel.com](http://fisherpaykel.com)

**DUCTED - CABINETY CLEARANCE RELATIONSHIPS**

Use of the 90° Vertical Elbow creates a relationship between the rear clearance for vertical ducting to the kick cavity height for horizontal ducting.

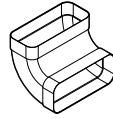

**90° VERTICAL ELBOW**

To minimise the depth of the rear clearance the kick cavity height must be at a maximum. To reduce kick cavity height the rear clearance must increase.

**IMPORTANT**

Only minimum and maximum relationships have been shown. There is a range of depth and heights, between what is shown, that is achievable. For further details and dimensions regarding the 90° Vertical Elbow refer to Data Sheets and 2D CAD files.

----- INDICATES CABINETY / PRODUCT DATUM  
 ----- INDICATES CABINETY CLEARANCES

**REAR CLEARANCE RELATIONSHIP TO KICK HEIGHT**

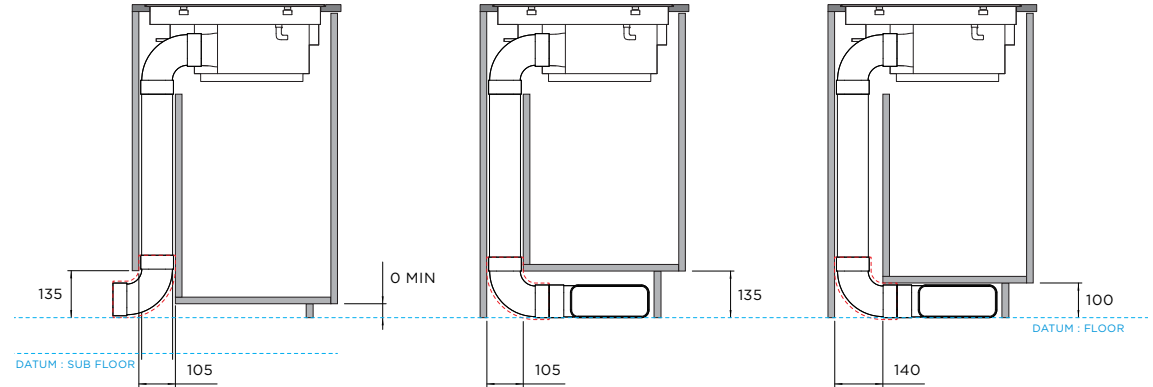

**PROFILE VIEW**  
 DUCT OUT  
 THRU FLOOR OR REAR CABINET  
 Minimum rear clearance,  
 minimum kick height

**PROFILE VIEW**  
 DUCT OUT  
 THRU KICK CAVITY  
 Minimum rear clearance,  
 maximum kick height

**PROFILE VIEW**  
 DUCT OUT  
 THRU KICK CAVITY  
 Maximum rear clearance,  
 minimum kick height

**RECIRCULATED - CABINETY CLEARANCE RELATIONSHIPS**

For recirculated installations the kick height needs to accommodate the filter box assembly. The louvres are designed to be trimmed to set heights of 150, 130, 115 and 100mm, while brackets can be trimmed to suit any kick height between 100-150mm.

Kick height is relational to the rear clearance requirement due to the geometry of the 90° Vertical Elbow. For further details and dimensions regarding the Recirculation Kit and filter box assembly refer to Optional Ducting pages and 2D CAD files.

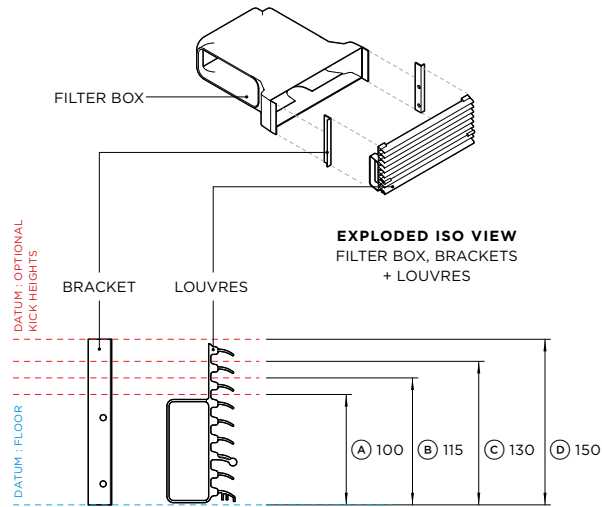

**EXPLODED PROFILE VIEW**  
 BRACKET + LOUVRES

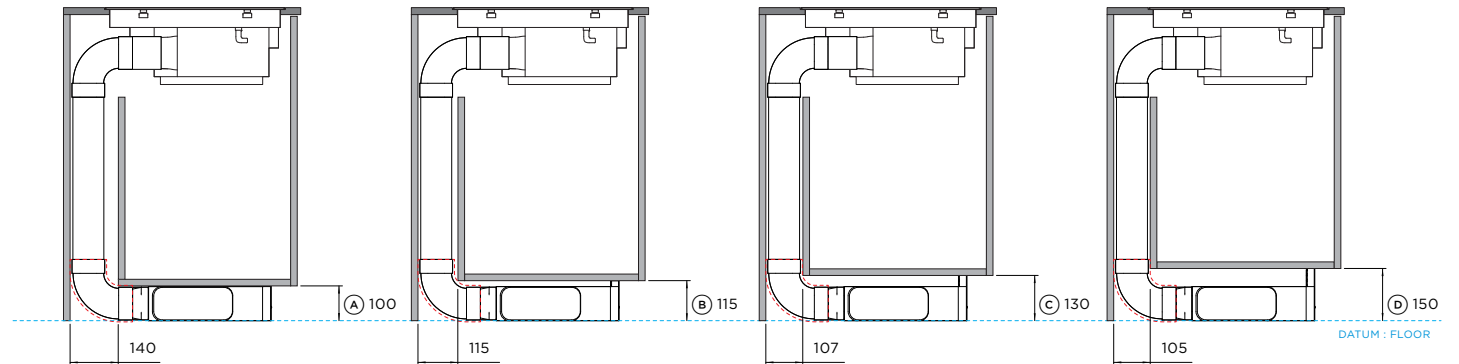

**PROFILE VIEW**  
 BRACKET + LOUVRES  
 TRIMMED TO 100MM

**PROFILE VIEW**  
 BRACKET + LOUVRES  
 TRIMMED TO 115MM

**PROFILE VIEW**  
 BRACKET + LOUVRES  
 TRIMMED TO 130MM

**PROFILE VIEW**  
 BRACKET + LOUVRES  
 NOT TRIMMED

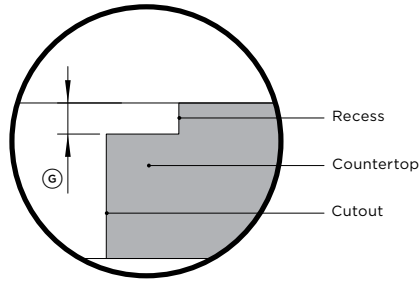
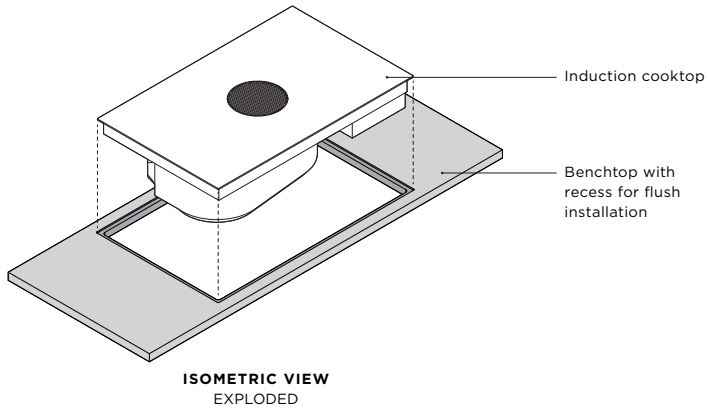

**DETAIL A**  
FRONT VIEW - CROSS SECTION  
Bench top without cooktop,  
recess for flush installation.

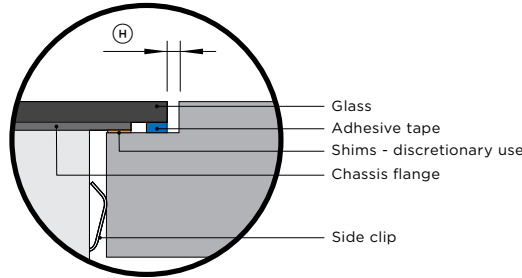
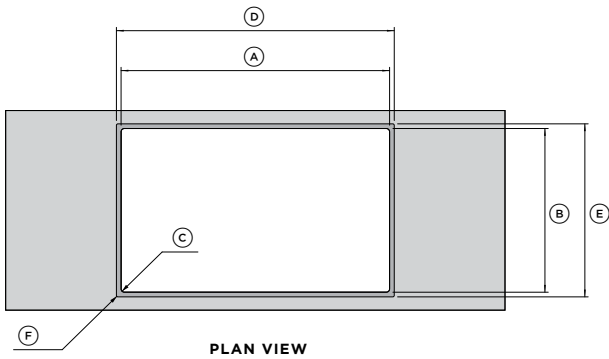

**DETAIL B**  
FRONT VIEW  
Benchtop with cooktop,  
flush installation.

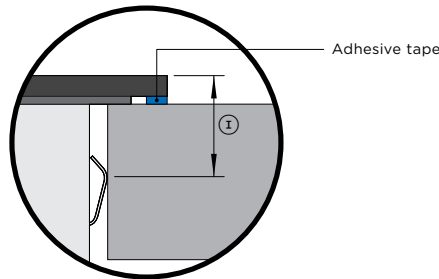
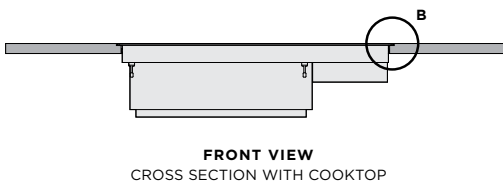
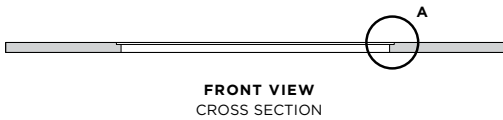

**DETAIL - SUPPLEMENTARY**  
FRONT VIEW  
Benchtop with cooktop,  
proud installation.

**BENCHTOP INSTALLATION OPTIONS**

The cooktop can be installed flush or proud in the countertop. Both installation scenarios require a cutout to accommodate the cooktop chassis. To achieve a flush finish between glass and countertop a recess is required.

Cutout Dimensions	mm
(A) Overall width of cutout	807
(B) Overall depth of cutout	492
(C) Maximum corner radii	10

Recess Dimensions for Flush Installation	mm
(D) Overall width of recess	835
(E) Overall depth of recess	520
(F) Corner radii of recess	4.5
(G) Overall height of recess (shims may be required during install)	6
(H) Distance between edge of recess and edge of glass	2.5

Recess Dimensions for Proud Installation	mm
(I) Distance from top of glass to clip interface	21

----- INDICATES CABINETRY / PRODUCT DATUM  
 - - - - - INDICATES CABINETRY CLEARANCES  
 - · - · - INDICATES CUTOUT

IMPORTANT NOTE: Throughout this guide, dimensions may vary by ±2mm (1/16"). Please read the installation manual for detailed information on installing the product. For full installation instructions & specifications visit [fisherpaykel.com](http://fisherpaykel.com)

**OVERFLOW TRAP REMOVAL**

The overflow trap is located below the cooktop chassis. To allow cleaning, the overflow trap is required to be disconnected and removed.

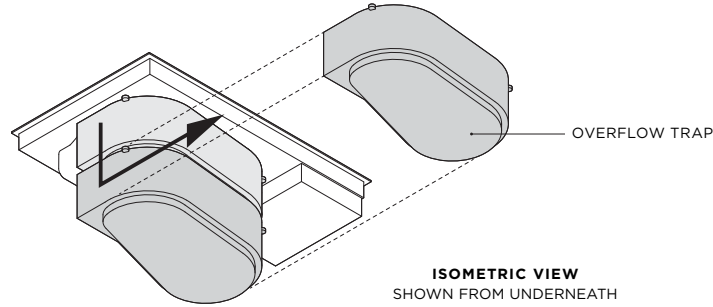

**OVERFLOW TRAP OVERVIEW**

The overflow trap is located below the cooktop chassis. To allow cleaning, the overflow trap is required to be disconnected and removed from cabinetry. Cabinetry needs to provide sufficient clearance space to allow ease of access, removal and replacement of the overflow trap.

Cabinetry shown on this page is to provide a guideline only and will need to be adapted to suit design requirements, specific location, cabinetry materials and construction methods.

**MOTION OF OVERFLOW TRAP REMOVAL**

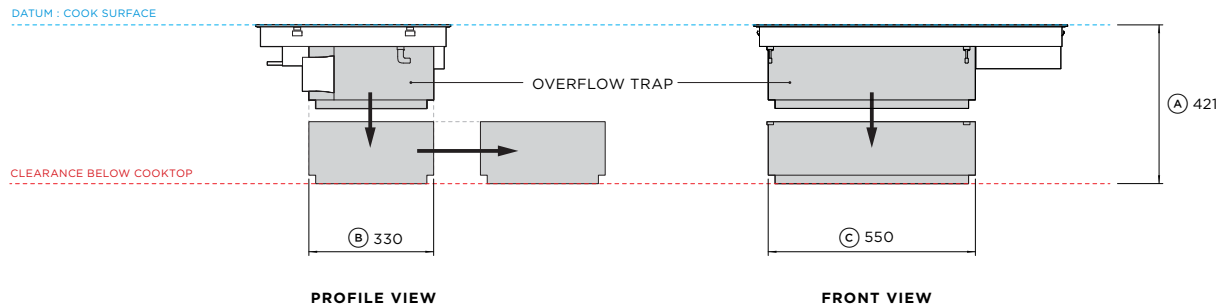

Overflow Trap Specifications	mm
Minimum clearance below cook surface to top of any appliance or obstruction below cooktop to allow removal of overflow trap for cleaning	421
Depth of overflow trap	330
Width of overflow trap	550

**CABINERY EXAMPLE**

Cabinetry needs to provide sufficient space to allow ease of access, removal and replacement of the overflow trap.

Cabinetry depicted is to provide a simplified example only and will need to be adapted to suit design requirements, specific location, cabinetry materials and construction methods.

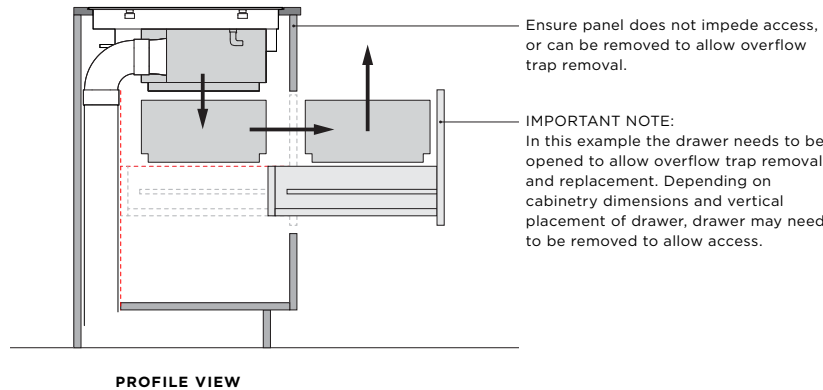

----- INDICATES CABINERY / PRODUCT DATUM  
 - - - - - INDICATES CABINERY CLEARANCES  
 - · - · - INDICATES CUTOUT

IMPORTANT NOTE: Throughout this guide, dimensions may vary by ±2mm (1/16"). Please read the installation manual for detailed information on installing the product. For full installation instructions & specifications visit [fisherpaykel.com](http://fisherpaykel.com)

