COFFEE MAKER INSTALLATION CONSIDERATIONS

Accessing your product specifications	3
Electrical connection	5

FISHER & PAYKEL

NZ AU UK IE SG CN EU

BUILT IN COFFEE MAKER

EB60MSG3, EB60MSB3, EB60CSX3, EB76PSX3

ACCESSING YOUR PRODUCT SPECIFICATIONS



For full product, cabinetry and service specifications, refer to the Planning Guide. To access the Planning Guide, scan the QR code or visit fisherpaykel.com/specify. Search by appliance type, product name or model code.

60CM MODELS

EB60MSG3, EB60MSB3, EB60CSX3, EB76PSX3

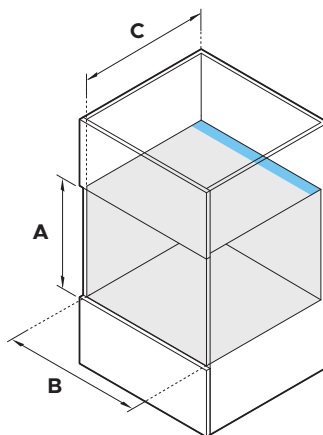
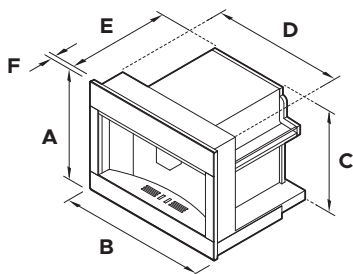

PRODUCT DIMENSIONS	mm
A Overall height	458
B Overall width	596
C Chassis height	445
D Chassis width	560
E Chassis depth	460
F Control panel thickness	20

CAVITY DIMENSIONS	mm
A Minimum inside height of cavity	450
B Minimum inside width of cavity	560
C Minimum inside depth of cavity*	545*

*Minimum total ventilation area of 280cm² is required.

ACCESSING YOUR PRODUCT SPECIFICATIONS



For full product, cabinetry and service specifications, refer to the Planning Guide. To access the Planning Guide, scan the QR code or visit fisherpaykel.com/specify. Search by appliance type, product name or model code.

76CM MODELS

EB76PSX3

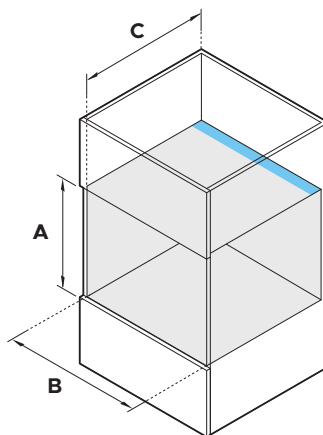
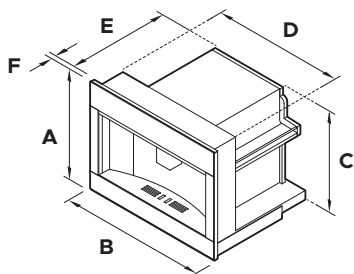

PRODUCT DIMENSIONS	mm
A Overall height	458
B Overall width	758
C Chassis height	445
D Chassis width	560
E Chassis depth	460
F Control panel thickness	24

CAVITY DIMENSIONS	mm
A Minimum inside height of cavity	450
B Minimum inside width of cavity	560
C Minimum inside depth of cavity*	550*

*Minimum total ventilation area of 280cm² is required.

ELECTRICAL CONNECTION

SPECIFICATIONS	EB60, EB76 MODELS
SERVICE (A)	10
SUPPLY (Hz)	50
VOLTAGE (V)	220 – 240V

