

The Haier logo is displayed in white text on a dark grey rectangular background in the top right corner of the page.

Haier

Freestanding Oven with Gas Cooktop

H500

HOR60S11MSX2, HOR90S11MSX2 and HOR90S11MBX2

H300

HOR90S8MSX2, HOR90S8MBX2

⚠ WARNING!

If the information in this manual is not followed exactly, a fire or explosion may result causing property damage, personal injury or death.

Do not store or use gasoline or other flammable vapors and liquids in the vicinity of this or any other appliance.

NEVER use this appliance as a space heater to heat or warm the room. Doing so may result in carbon monoxide poisoning and overheating of the appliance.

WHAT TO DO IF YOU SMELL GAS

- Do not try to light any appliance.
- Do not touch any electrical switch.
- Do not use any phone in your building.
- Immediately call your gas supplier from a neighbor's phone. Follow the gas supplier's instructions.
- If you cannot reach your gas supplier, call the fire department.

Installation and service must be performed by a qualified installer, service agency or the gas supplier.

CONTENTS

Safety and warnings	4
Product overview	9
First use	12
Cooking functions- H300	15
Cooking functions- H500	16
Using grill functions	17
Shelves	18
Care and cleaning	19
Cleaning the oven door	21
Hydro clean	23
Troubleshooting	24
Manufacturer's warranty	25
Customer service	27

SAFETY AND WARNINGS

⚠ WARNING!



Explosion Hazard

Failure to follow this advice may result in death or serious injury.

- Do not store flammable materials such as gasoline near the cooktop.
- Do not use or store flammable materials in the appliance drawer or near this appliance
- Do not spray aerosols on the vicinity of this appliance while it is in operation.

⚠ WARNING!



Electrical Shock Hazard

Failure to follow this advice may result in electrical shock or death.

- Switch the cooker off at the wall before replacing fuses or the oven lamp.

⚠ WARNING!



Poisoning Hazard

Failure to follow this advice may result in poisoning or death.

- Do not use this appliance as a space heater. Doing so may result in carbon monoxide poisoning and overheating of the appliance.

SAFETY AND WARNINGS

⚠ WARNING!



Cut Hazard

Failure to use caution could result in injury or cuts.

- Take care - some edges are sharp.

⚠ WARNING!



Fire Hazard

Failure to follow this advice may result in overheating, burning, and injury.

- Never leave the cooktop unattended when in use. Boilover causes smoking and greasy spillovers that may ignite.
- Do not place aluminium foil, dishes, trays, water or ice on the oven floor during cooking, as doing so will irreversibly damage the enamel; lining the oven with aluminium foil may even cause fire.
- Never use your appliance for warming or heating the room. Persons could be burned or injured or a fire could start.
- Storage in or on appliance: flammable materials should not be stored in an oven or near its surface.

⚠ WARNING!

Hot Surface Hazard

Failure to follow this advice could result in burns and scalds.

- Accessible parts may become hot when this cooker is in use.
- To avoid burns and scalds keep children away.
- Do not touch hot surfaces inside the oven.
- Use oven mitts or other protection when handling hot surfaces such as oven shelves or dishes.
- Take care when opening the oven door.
- Let hot air or steam escape before removing or replacing food.
- Do not touch the cooktop components, burners, trivets/pan supports or the base when hot.
- Before cleaning, turn the cooker off and make sure it is cool.



SAFETY AND WARNINGS

READ AND SAVE THIS GUIDE! IMPORTANT SAFETY INSTRUCTIONS

To reduce the risk of fire, electrical shock, injury to persons or damage when using the oven, follow the important safety instructions listed below. Read all the instructions before using the oven. Use the oven only for its intended purpose as described in these instructions.

General

- Be sure your appliance is properly installed and earthed by a qualified technician.
- Isolating switch: make sure this oven is connected to a circuit which incorporates an isolating switch providing full disconnection from the power supply.
- Household appliances are not intended to be played with by children.
- Do not leave children alone. Children should not be left alone or unattended in the area where the appliance is in use. They should never be allowed to sit or stand on any part of the appliance.
- When heating food in plastic or paper containers, keep an eye on the oven due to the possibility of ignition.
- Children of less than 8 years old must be kept away from the appliance unless continuously supervised.
- This appliance can be used by children aged from 8 years and above, and persons with reduced physical, sensory or mental capabilities or lack of experience and knowledge, if they have been given supervision or instruction concerning the use of the appliance in a safe way and they understand the hazards involved.
- The contents of feeding bottles and baby food jars shall be stirred or shaken and the temperature checked before consumption, in order to avoid burns.
- Do not store things children might want above the oven. Children could be burned or injured while climbing on the oven to retrieve items.
- Cleaning and user maintenance shall not be done by children without supervision.
- Clean only the parts of parts listed in this manual.
- Do not place aluminium foil, dishes, trays, water or ice on the oven floor during cooking as this will irreversibly damage the enamel.
- Do not modify this appliance.
- Always position shelves in the desired location while the oven is cool (before preheating). If a shelf must be removed while the oven is hot, do not let the oven mitts or potholder contact hot heating elements in the oven or the base of the oven.
- Do not place heavy objects on the oven door.
- Do not heat unopened food containers. They can build up pressure that may cause the container to burst and result in injury.
- The cooking chamber must only be cooled with the door closed. Check that nothing is stuck on the door of the appliance. Even if the door is only ajar, nearby cabinets can be damaged over time.
- Do not rest or lean on the open door of the appliance and do not put dishware or accessories on it.
- This appliance is intended to be used in household and similar applications such as:
 - Staff kitchen areas in shops, offices and other working environments;
 - Farm houses;
 - By clients in hotels, motels and other residential environments;
 - Bed and breakfast type environments.
- Always keep oven vents unobstructed.
- Do not use the oven if the door or the seals of the door are damaged. The oven may not be used until it is repaired by a qualified service technician.
- Do not operate your appliance by means of an external timer or separate remote control system.

SAFETY AND WARNINGS

- Do not use harsh abrasive cleaners or sharp metal scrapers to clean the oven door glass, since they can scratch the surface, which may result in shattering of the glass.
- CAUTION: Hot air can blow from the vent at the base of the oven as part of the oven's cooling system.

Installation

- Ensure your appliance is properly installed and earthed by a qualified technician.
- Ensure this oven is connected to a circuit which incorporates an isolating switch providing full disconnection from the power supply.
- Do not install or operate the appliance if it is damaged or not working properly. If you receive a damaged product, contact your dealer or installer immediately.
- Please make this information available to the person installing the appliance—doing so could reduce your installation costs.
- This appliance must be installed and connected to the mains power supply only by a suitably qualified person according to these installation instructions and in compliance with any applicable local building and electricity regulations. Failure to install the appliance correctly could invalidate any warranty or liability claims.
- If the power supply cable is damaged, it must be replaced by the manufacturer, its service agent or similarly qualified person in order to avoid a hazard.
- Isolating switch: make sure this oven is connected to a circuit which incorporates an isolating switch providing full disconnection from the power supply in accordance with the wiring rules.
- The oven must be earthed.
- Do not use adaptors, reducers or branching devices to connect the oven to the mains electricity supply, as they can cause overheating and burning.
- The appliance must not be installed behind a decorative door in order to avoid overheating.
- Please take extra care not to damage the lower trim of the oven during installation. The trim is important for correct air circulation and allows the door to open and close without obstruction. The manufacturer does not accept any responsibility for damage resulting from incorrect installation.

Food safety

- Leave food in the oven for as short a time as possible before and after cooking. This is to avoid contamination by organisms which may cause food poisoning. Take particular care during warm weather.

Servicing

- Do not repair or replace any part of the appliance unless specifically recommended in the user guide. All other servicing should be undertaken by a Fisher & Paykel trained and supported service technician or qualified person.

Fire Hazard

- Do not use water on grease fires. Smother the fire or flame or use a dry chemical or foam type extinguisher.
- Use only dry oven mitts or potholders. Moist or damp potholders on hot surfaces could result in burns from steam. Do not let potholders touch hot areas or heating elements. Do not use a towel or a bulky cloth for a potholder. It could catch fire.
- Do not heat unopened food containers. They can build up pressure that may cause the container to burst and result in injury.

PRODUCT OVERVIEW

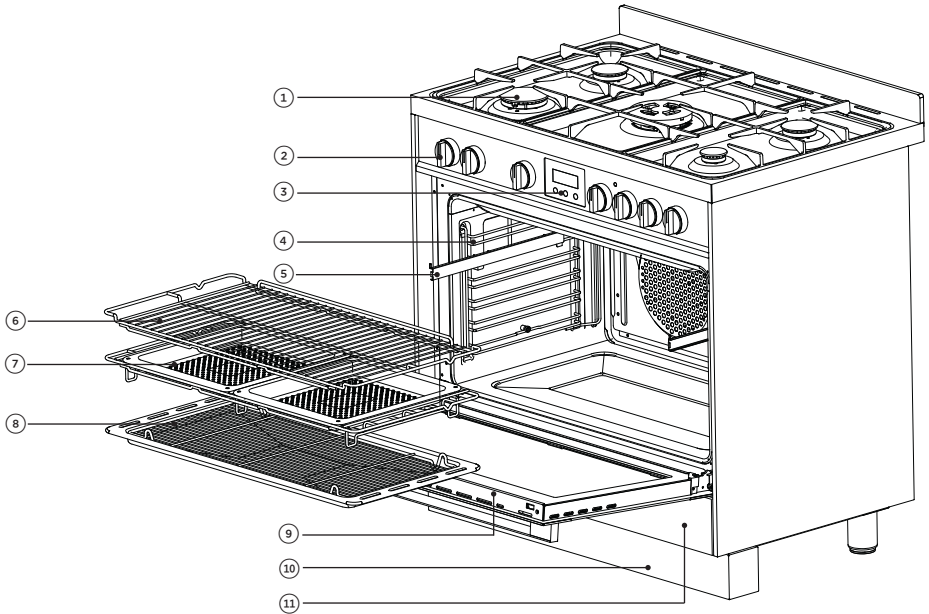

Features and accessories

1	Elements	7	Air fry trays*
2	Control dials	8	Roasting dish + Grill insert
3	Control panel	9	Oven door
4	Side racks	10	Toe kick cover
5	Telescopic sliders*	11	Storage drawer
6	Wire rack		

*Only available with H500 models.

PRODUCT OVERVIEW

Control panel 90cm

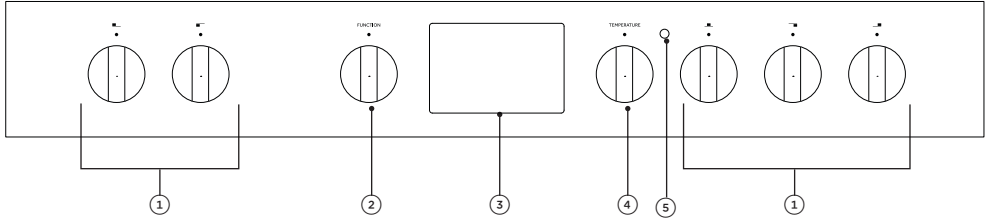

1 Element dials

4 Temperature control dial

2 Function control dial

5 Oven heating light*

3 Control display

*Illuminated only when oven is heating up, light will turn off once set temperature is reached.

Control panel 60cm

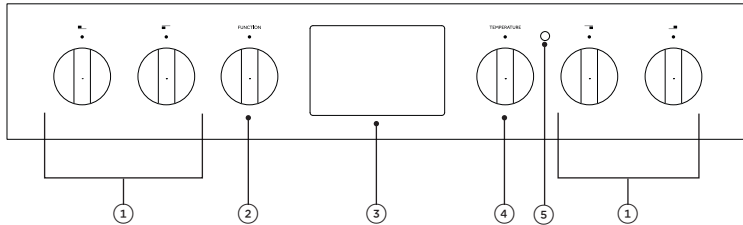

1 Element dials

4 Temperature control dial

2 Function control dial

5 Oven heating light*

3 Control display

*Illuminated only when oven is heating up, light will turn off once set temperature is reached.

PRODUCT OVERVIEW

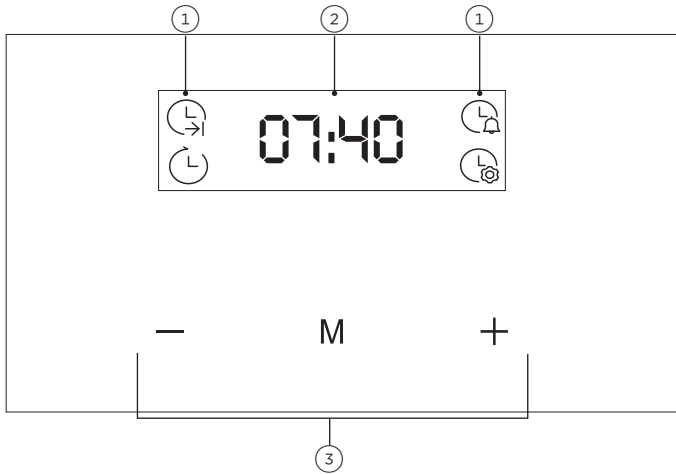

Control display

1	Timer functions		Cook duration
			Delay start
			Timer
			Clock settings
2	Time/ Temperature display	Displays clock, cook duration, delay start, timer and temperature.	
3	Selector buttons	M	Press to cycle through functions.
		- +	Press to increase or decrease time.

FIRST USE

Preparing your oven

The quality of your cookware can affect cooking performance. Choose a pan with a diameter that is at least as large as the heating zone. Do not use pans with a concave and convex base. Always remember to put a proper cover on the pan. We recommend the use of pans with thick even bases.

If the zones and pans are soiled it is impossible to make full use of the heat.

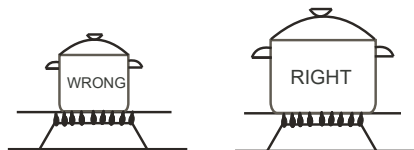

Heat level selection

The heating elements have different levels of heat. The level of heat can be adjusted gradually by turning the appropriate knob to the right or left.

1-2 Maintaining temperature, slow cooking small quantities of food (min power).

3 Slow cooking.

4-5 Slow cooking of large quantities, and slow frying of large portions.

6 Frying and preparing soup basis.

7-8 Frying.

9 Boiling, browning or frying (maximum power).

FIRST USE

Preparing your oven

Before using your oven for the first time, remove and wash all accessories, and clean the inside of the oven with a damp, soft cloth and mild detergent. Wipe the outside with a damp, soft cloth. Dry with a clean cloth.

Run the empty oven at maximum temperature for 60 minutes to remove the newness smell. The oven may smoke slightly during this process. This is normal. Opening a window is recommended to allow air flow during the prep burn.

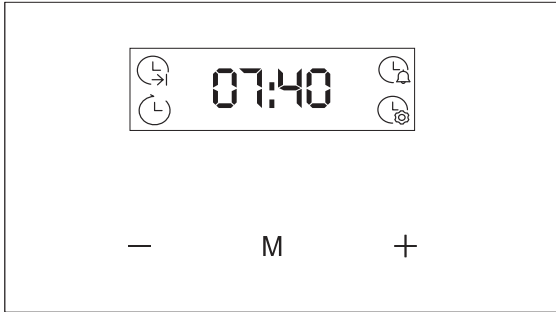

Setting the clock

Following installation or a power reset, the display will flash and show 12:00. Press increase + or decrease - to set time.

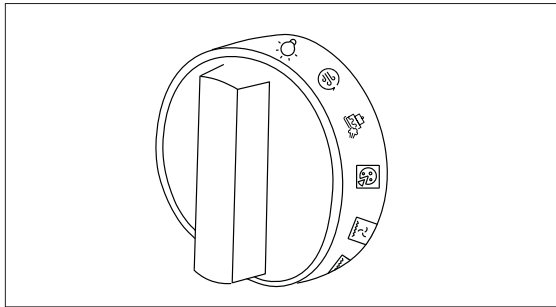

Setting a function

Turn the function selector to the desired function. See 'Cooking functions' for details.

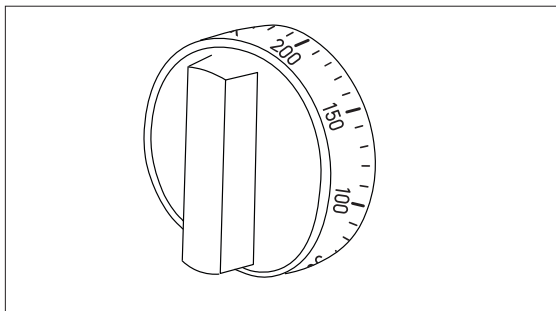

Setting the temperature

Turn the temperature selector to the desired temperature. The oven will start once the time, function and temperature are set. The oven heating light will turn on to indicate that the oven is warming up. It will switch off once the oven has reached the set temperature.

FIRST USE



Setting cook duration

Press M to select , then press increase + or decrease - to set the cook duration.

The cooking function will turn off automatically when the set time has elapsed, and an alarm will sound.

Press any key to stop the alarm.

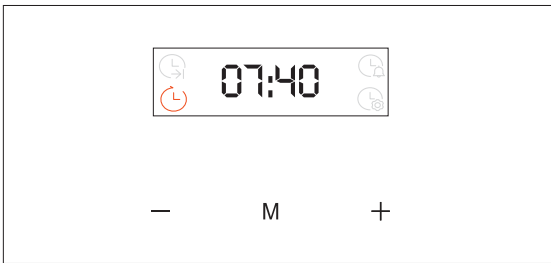

Setting delay cook

Delay cook allows you to schedule a cook up to 24 hours in advance by setting a function, cooking duration and desired cooking start time.

Press M then select , then press increase + or decrease - to set the cooking end time.



Setting the timer

Press M to select , then press increase + or decrease - to set the timer.

Press any key to stop the alarm.

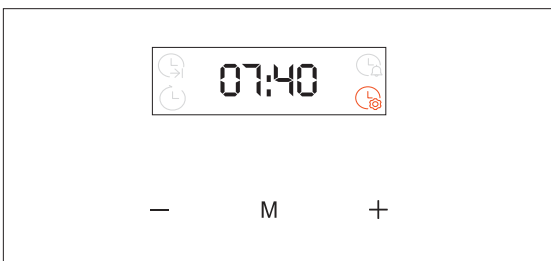

Changing the displayed time

Press M to select , then press increase + or decrease - to set clock.











COOKING FUNCTIONS- H300

Cooking functions for Models: HOR90S8MSX2 & HOR90S8MBX2

FUNCTION	DESCRIPTION
 LIGHT	Turns the oven light ON/OFF.
 DEFROST	Fan circulates air at room temperature around the frozen food to speed up the defrosting process.
 BAKE	Ideal for cakes, breads, biscuits and quiches on one level. Uses both upper and lower heating elements.
 FAN BAKE	Ideal for roasts, casseroles, vegetables and pies on one level and for achieving surface browning.
 TRADITIONAL BAKE	Ideal for traditional recipes and foods that have a pastry base and require delicate baking or minimal surface browning.
 FAN FORCED	Ideal for multilevel cooking. Uses the rear element in conjunction with the fan. Recommended for most applications, including poultry, pastries and vegetables.
 MAXI GRILL	Ideal for sausages, steaks and toast. The entire area below the grill element becomes hot. Use with the door closed. Turn food halfway through cooking (if necessary).
 MAXI GRILL+ FAN	Ideal for larger cuts of meat that require longer cooking with surface browning. Use with the door closed. Slide a tray under the shelf to collect juices. Turn food halfway through cooking (if necessary).
 PASTRY	Ideal for fruit flans, tarts, quiches and pastries. Prevents food from drying and encourages rising in cakes, bread dough and other bottom-cooked food.

COOKING FUNCTIONS- H500

Cooking functions for Models: HOR60S11MSX2, HOR90S11MSX2 & HOR90S11MBX2

FUNCTION	DESCRIPTION
 LIGHT	Turns the oven light ON/OFF.
 DEFROST	Fan circulates air at room temperature around the frozen food to speed up the defrosting process.
 BAKE	Ideal for cakes, breads, biscuits and quiches on one level. Uses both upper and lower heating elements.
 FAN BAKE	Ideal for roasts, casseroles, vegetables and pies on one level and for achieving surface browning.
 TRADITIONAL BAKE	Ideal for traditional recipes and foods that have a pastry base and require delicate baking or minimal surface browning.
 FAN FORCED	Ideal for multilevel cooking. Uses the rear element in conjunction with the fan. Recommended for most applications, including poultry, pastries and vegetables.
 MAXI GRILL	Ideal for sausages, steaks and toast. The entire area below the grill element becomes hot. Use with the door closed. Turn food halfway through cooking (If necessary).
 MAXI GRILL+ FAN	Ideal for larger cuts of meat that require longer cooking with surface browning. Use with the door closed. Slide a tray under the shelf to collect juices. Turn food halfway through cooking (If necessary).
 PIZZA	Ideal for achieving a crispy base on all kinds of pizzas without preheating the oven. We recommend using lower shelf positions and a pizza stone. Set a cook duration time manually.
 BAKERY + STEAM	Ideal for bread, pastries, and cakes, it combines traditional baking with steam to deliver professional bakery results at home. Pour 300ml for 90cm oven and 150ml for 60cm oven of water into the base of the oven cavity when the oven is cold, then preheat oven.
 AIR FRY	Ideal for preparing frozen foods or crumbed par-cooked foods which are usually fried.

USING GRILL FUNCTIONS

IMPORTANT! While using grill, maxi grill, fan grill functions it is recommended to keep oven door closed. Accessible parts can become hot and it is best to keep children away from the oven.

Choice of cookware.

Keep in mind that the pan base diameter should always be larger than the burner flame crown, and the pan should have a lid and the pan height should not exceed its diameter.. The ideal pan size is about 2.5 to 3 times the diameter of the burner:

- Auxiliary burner: 90–150 mm pan diameter
- Medium burner: 160–220 mm pan diameter
- Large burner: 200–240 mm pan diameter

Ignition without an igniter.

- Light a match, than press in the knob to the end and turn it to the left large flame.
- Ignite with a match. Set required flame size then switch off the burner after finishing cooking, turning the knob right the off position.

Knob ignition

Press in the knob to the end and turn it left to the large flame. The hold until the gas is lit. After the flame is lit release the pressure on the knob and set a required flame size.

Select the appropriate flame.

A correctly adjusted burner has a light blue flame with a clearly visible internal cone. Flame size depends on the position of the burner knob which has been set.

Depending on requirements, flame size can be set in a continuous manner.

CAUTION! For models with a surface burner safety valve, press and hold the knob in the large flame position for about 10 seconds to activate the safety device.

If ignition fails (e.g., due to power loss or moisture), light the burner with a match or lighter.

After ignition, keep the knob pressed for 10 seconds to stabilize the flame.

If the burner does not ignite within 15 seconds, turn it off and wait at least one minute before trying again.

Do not place items such as flame tamers or griddle plates between the pan and pan support.

Use only the supplied wok stand, and avoid large or heavy pots that may bend the pan support or deflect the flame.

Ensure the pan is centred and stable without overhanging the appliance.

Avoid using knob positions between settings, as the flame may become unstable or go out.

If the flame goes out, turn the burner off, wait at least one minute, then re-ignite.

Always ignite burners with cookware in place.

Models with a burner protection valve automatically cut off the gas if the flame goes out (e.g., due to spillage).

If this happens, the burner must be manually re-ignited.

SHELVES

Positioning shelves and trays

- Baking pans and accessories to be inserted into the oven in 6 guiding levels.

Important!

- Always position oven shelves before switching the oven on.
Remove any unused shelves or baking utensils from the oven.
- After using the grill, accessible parts of the cooker can become extremely hot.
Keep children away from the appliance to prevent burns.

Inserting a removing the shelves and tray.

- Make sure the guard rail is at the back, facing up.
- Position the shelf so that it rests on the side rack wire.
- Tilt the front up slightly to help the safety stops clear the side racks.
- Lower the shelf back onto the side rack wires and slide all the way into the oven.
- Invert the process above for removing the shelf.

Telescopic Runners

The telescopic sliding shelf supports make it safer and easier to insert and remove oven shelves or trays.

They lock in place when fully extended and can be fitted to any shelf position between levels 2 and 6.

Fitting and Removal

- To remove: Pull along the bottom edge in the direction shown while pivoting from the top edge.
- To fit: Reverse the above process, ensuring all retention brackets on the runner are properly engaged with the wire rack.

Important

- Ensure the slides extend toward the oven door.
- Fit both sides at the same level.
- When positioned, the tray or shelf should sit between the front and rear stoppers on the runners.

Baking pans and accessories (oven grid, baking tray, etc) may be inserted into the oven in 6 guiding levels. Appropriate levels are indicated in the tables that follow. Always count levels from the bottom upwards!

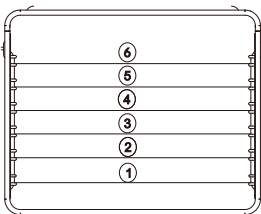

CARE AND CLEANING

The life of your product can be extended through regular cleaning. Ensure oven knobs are turned off and oven is cool before carrying out manual cleaning operations. Never use abrasive detergents, steel wool or sharp objects for cleaning as these may damage enamelled and stainless steel parts. Use only water, soap, or bleach-based detergents (ammonia).

Rubber door seal

Clean the seals with a slightly damp sponge. Abrasive detergents should not be used for these parts.

Baking tray

Allow to cool, then wash the tray in hot, soapy water or in the dishwasher.

Racks

Clean with a solution of mild detergent and hot water. Pre-soak burnt-on stains in a solution of laundry powder and hot water, then remove with a dishwashing brush.

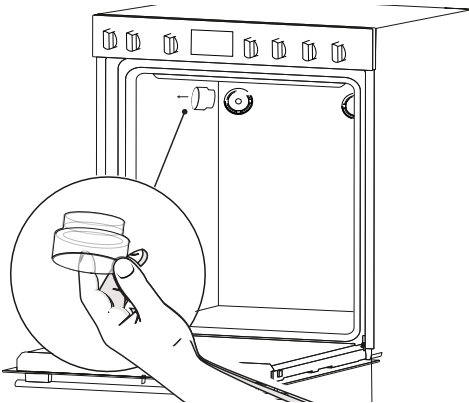

Changing the light bulbs

1. Disconnect the oven from the power supply, then remove the glass light cover.

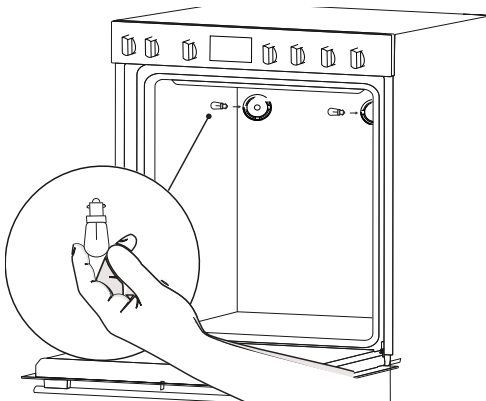

2. Unscrew the light bulb and replace with a new bulb of the same type. Refit the glass light cover.

CARE AND CLEANING

Wipe the supports with a damp cloth and a mild detergent only. Do not wash them in the dishwasher, immerse them in soapy water, or use oven cleaner on them.

Grill element

Gas grid, cooking area and burner components should be cleaned with warm water and mild detergent for manual washing of dishes.

Thermal element and ignition device should be cleaned with soft brush. To ensure perfect operation, these elements must always be thoroughly clean.

Clean the crown and the crown cap. On the burner crown free of dirt. Always keep the gas outlets nozzles.

Side racks

Clean with a solution of mild detergent and hot water.

Storage door

Storage drawer runs on rails, pull from bottom in order to access the compartment. For cleaning the interior painted surface, wipe out with soft cloth using a mixture of warm water and mild detergent.

Oven interior

Pour a small amount of water into the base on the oven, select the steam clean feature to clean. After cleaning the oven chamber wipe it dry.

Front side of the casting

For cleaning of frontal part of the cooker use the usual cleaning agents and follow the manufacturer's instructions.

Never use any aggressive cleaning agents or dish cleaning accessories which might cause scratches.

Enamel coated and plastic surface

Clean the knob and handles with soft cloth and liquid cleaners, intended for use of smooth enamel surfaces.

CLEANING THE OVEN DOOR

Everyday cleaning

It is advisable to clean the glass window with an absorbent kitchen towel after every use of the oven. To remove more stubborn stains, you can use a detergent-soaked sponge, well wrung out, and then rinse with water.

90cm oven.

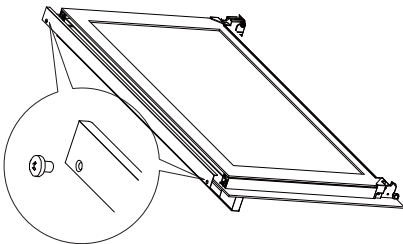
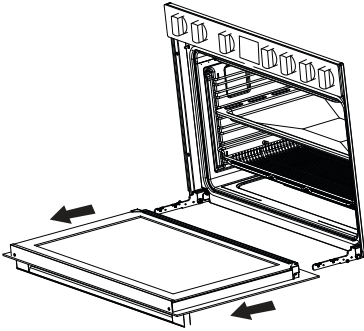
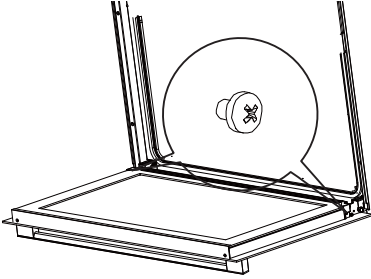

Removal and cleaning of the door glass.

1. Open the oven door fully, then remove the screws that secure the hinges to the body of the oven.

2. Pull the door out towards you and place it on a flat, protected surface.

3. Remove the screws at the top corners of the door, then lift the edge of the inner pane and carefully slide it out.

4. Remove the screws at the top corners of the door, then lift the edge of the inner pane and carefully slide it out.



CLEANING THE OVEN DOOR

60cm oven.

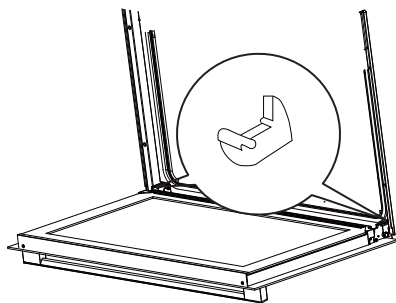

Removal and cleaning of the door glass.

1. Open the oven door fully, then tilt the safety catch on the hinge upwards.

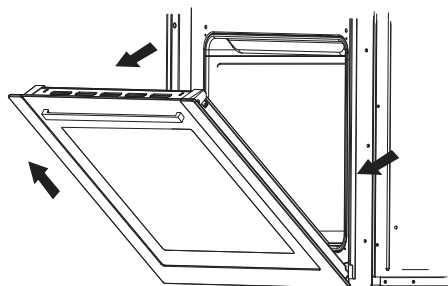

2. Close the door halfway, lift and pull it towards you and place it on a flat, protected surface.

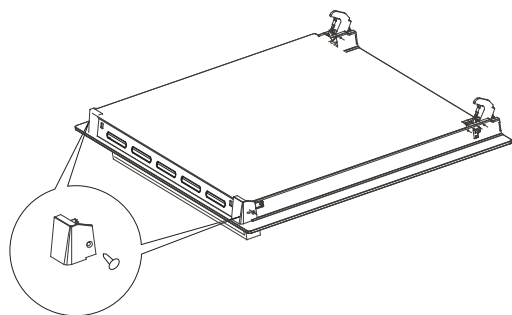

3. Unscrew and detach the plastic end caps that are located at the top corners of the door. Then lift the edge of the inner pane and carefully slide it out.



4. Unscrew the remaining brackets on both sides of the middle panel, then lift the edge of the inner pane and carefully slide it out.

HYDRO CLEAN

Hydro clean

This function uses steam to clean light levels of residue from the oven interior in a quick and eco-friendly way. Always use distilled or drinkable water and for the best performance begin the function when oven is cool.

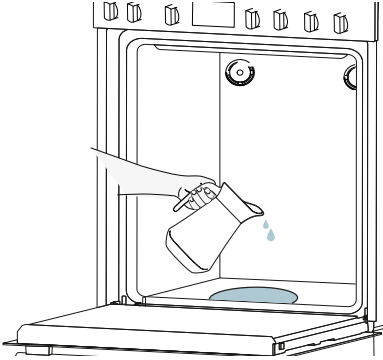

1. Remove all racks, trays and side racks from the oven. Wipe away as much dirt as possible then pour 300ml of water for 90cm oven and 150ml for 60cm oven of water into the base of the oven.

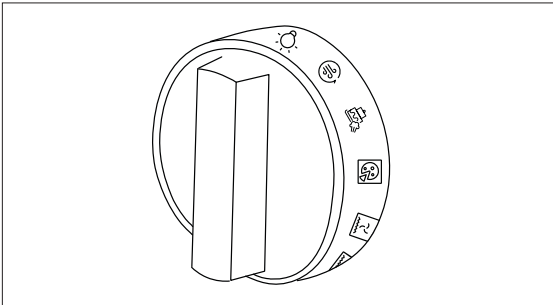

2. Press the traditional bake function and preheat the oven to 100°C. Then set the cook duration to 20 minutes.

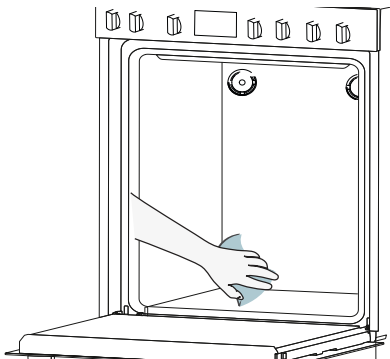

3. Wait for the oven to cool completely before wiping the interior clean with a soft, damp cloth.

TROUBLESHOOTING

PROBLEM	POSSIBLE CAUSES	WHAT TO DO
The oven does not work	No power.	Check that the mains power supply (wall switch) is turned on, the fuse has not tripped and there is no power outage in your area.
	No function has been set.	Ensure a function has been selected and temperature set.
The lights are not operating when I open the oven door	The oven lights have blown.	Replace the lights. See 'Changing the light bulbs' on page 17.
The oven is not heating	The door is not fully closed.	Make sure the door is properly closed.
	The door has been opened too often during cooking.	Avoid opening the door too often during cooking.
A glass pane in the door has cracked, chipped or shattered	The glass has been knocked or cleaned incorrectly.	You must NOT use the oven. Call your Authorised Repairer or Customer Service.
Hot air is coming out of the vents when the oven is off	The cooling fan is running.	This is normal. You do not need to do anything.
The fan comes on when I select a function that does not use a fan	The fan starts automatically while preheating.	This is normal. The fan will turn off when the oven reaches temperature.
00:00 is flashing on the display	The oven was disconnected from the mains or there was a power cut.	The clock needs to be reset. See 'Setting the clock'.
Burner flame is not steady	Wrong setting of gas.	Expert will need to set the gas escape correctly.
Burner flame suddenly changes	Incorrect assembly of burner components.	Assemble the burner components correctly.
The flame goes off after ignition	Early release of the control button. Control button is not pushed in firmly.	Keep the button pressed longer. Before releasing the button, give it one final firm push.
The color of the cooking zone	Normal situation, caused by the high temperature.	Clean the grid with metal cleaning agents.
Oven heating light turning on throughout cooking.	Fluctuating temperature of internal oven.	This is normal. You do not need to do anything.

MANUFACTURER'S WARRANTY

Please read this warranty card carefully. Attach your purchase receipt to this warranty card and keep in a safe place. You must produce both warranty card and proof of purchase in the event of a warranty repair being required.

When you purchase any new Haier Product you automatically receive a two year Manufacturer's Warranty covering parts and labour for servicing.

The Manufacturer undertakes to:

Repair or, at its option, replace without cost to the owner either for material or labour any part of the Product, the serial number of which appears on the Product, which is found to be defective within TWO YEARS from the date of purchase.

This warranty DOES NOT cover:

- Ⓐ Service calls which are not related to any defect in the Product. The cost of a service call will be charged if the problem is not found to be a Product related fault. For example:
 - ① Correct the installation of the product.
 - ② Provide Instruction on use of the product or change the setup of the product.
 - ③ Replace house fuses or correct house wiring.
 - ④ Correcting faults) caused by the user.
 - ⑤ Noise or vibration that is considered normal.
 - ⑥ Water on the floor due to incorrect loading or excessive suds.
 - ⑦ Blocked pumps, removal of foreign objects/substances from the machine, including the pump and inlet house filters.
 - ⑧ Correcting damage caused by pests, eg. Rats, cockroaches etc.
 - ⑨ Correct corrosion or discolouration due to chemical attack.
 - ⑩ Power outages or surges.
- Ⓑ Defects caused by factors other than:
 - ① Normal domestic use or
 - ② Use in accordance with the Product's User Guide.
- Ⓒ Defects to the Product caused by accident, neglect, misuse or 'Act of God'.
- Ⓓ The cost of repairs carried out by non-authorized repairers or the cost of correcting such unauthorised repairs.
- Ⓔ Normal recommended maintenance as set out in the Product's User Guide.
- Ⓕ Repairs when the appliance has been dismantled, repaired or serviced by other than an AUTHORISED CUSTOMER SERVICE CENTRE or the selling dealer.
- Ⓖ Pick up and delivery.
- Ⓖ Transportation or travelling costs involved in the repair when the product is installed outside the AUTHORISED CUSTOMER SERVICE CENTRE'S normal service area.

This product has been designed for use in a normal domestic environment. It is not intended for commercial use. Doing so may affect product warranty.

Service under this warranty must be provided by an Authorised Service Repairer (refer to the Customer Care section for contact details). Such service shall be provided during normal business hours. This warranty certificate should be shown when making any claim.

MANUFACTURER'S WARRANTY

Note:

This Warranty is an extra benefit and does not affect your legal rights and applies only to product purchased in New Zealand and Australia. Please keep this Warranty Card in a safe place.

For Australian customers:

Our goods come with guarantees that cannot be excluded under the Australian Consumer Law. You are entitled to a replacement or refund for a major failure and for compensation for any other reasonably foreseeable loss or damage. You are also entitled to have the goods repaired or replaced if the goods fail to be of acceptable quality and the failure does not amount to a major failure.

CUSTOMER SERVICE

We recommend our Haier Customer Service and the use of original spare parts.

If you have a problem with your appliance, please first check TROUBLESHOOTING. If you cannot find a solution there, please contact:

- Your local dealer
- The Service & Support area at
www.haier.com.au or
www.haier.co.nz

Where you can activate the service claim and also find FAQs.

To contact our Service, ensure that you have the following data available.
The information can be found on the rating plate at the door.

Model _____

Serial No. _____

Complete and keep for safe reference:

Model _____

Serial No. _____

Purchase Date _____

Purchaser _____

Dealer _____

Suburb _____

Town _____

Country _____

Haier

WWW.HAIER.COM.AU
WWW.HAIER.CO.NZ

□□□□40*8mm□□□□□□