

FISHER & PAYKEL

BLACK INDUCTION COOKTOP



CI302DTB, CI603DTB, CI604DTB,
CI764DTB, CI905DTB models

INSTALLATION GUIDE

NZ AU UK IE SG HK

⚠ WARNING!



Electric Shock Hazard

Failure to follow this advice may result in electric shock or death.

- Disconnect the appliance from the mains electricity supply before carrying out any work or maintenance.
- Connection to a good earth wiring system is essential and mandatory.
- Alterations to the domestic wiring system must only be made by a qualified electrician.

⚠ WARNING!



Cut Hazard

Failure to use caution could result in injury.

- Take care: some edges are sharp.

READ AND SAVE THIS GUIDE

General Use

- Read these instructions carefully before installing this product.
- Save these instructions for the local electrical inspector's use.
- Installation must comply with your local building and local electricity regulations.
- This appliance is to be installed and serviced only by Fisher & Paykel trained and supported service technician or qualified person.
- The manufacturer accepts no responsibility for the incorrect installation of appliances. Incorrect installation may result in personal injury, damage to property and may invalidate any warranty or liability claims.
- Do not modify this appliance.
- Do not use or store flammable materials on or near this appliance.
- Packing elements (eg plastic bags, polystyrene foam, staples, packing straps etc) and tools should not be left around during and after installation, especially if they are within easy reach of children, as these may cause serious injuries.
- Make sure you recycle the packaging material.
- Before disposing of any appliance, make sure that it can no longer be used and that all hazardous parts are removed or made harmless, so that children playing with the old appliance cannot harm themselves.
- Only genuine replacement parts may be used for servicing the appliance. These are available from your nearest Fisher & Paykel Service Center.
- This cooktop must be connected to the mains power supply only by a suitably qualified person.
- DO NOT use adapters, reducers, or branching devices when connecting the cooktop to the mains power supply to prevent overheating and fire.
- The power supply cable must not touch any hot parts and must be positioned so that its temperature will not exceed 75°C at any point.
- This cooktop requires adequate supply of cool air to fully function. The base of the cooktop must have direct unrestricted ventilation to the room where the cooktop is installed. There must be a 4mm air gap at the front of the cooktop. (See 'Venting Clearances' page)

INSTALLATION CONSIDERATIONS

BEFORE INSTALLATION

Before installation, please ensure the following:

- A suitable disconnection switch is incorporated in the permanent wiring, mounted and positioned to comply with the local wiring rules and regulations. A means of disconnection with at least a 3 mm air gap contact separation in all poles must be incorporated into the fixed wiring in accordance with the wiring rules, unless the local wiring rules allow for alternative means.
- The benchtop is made of a heat resistant material.
- The power supply cable is not accessible through cupboard doors or drawers.
- There is adequate flow of cool air from the cabinetry to the base of the cooktop. You may ventilate from adjacent cupboards, but ensure that the available air supply will not be restricted.
- The ventilation area must be at least 50mm diameter holes or of equivalent area.
- The isolating switch is easily accessible by the customer.
- Use heat-resistant and easy-to-clean finishes (such as ceramic tiles) for the wall surfaces surrounding the cooktop.
- The cooktop will not be installed directly above a dishwasher, fridge, freezer, washing machine or clothes dryer, as the humidity may damage the cooktop electronics.
- DO NOT install the cooktop directly above a dishwasher, fridge, freezer, washing machine or clothes dryer, as the humidity may damage the cooktop electronics.
- If the cooktop is installed above an oven, ensure the oven has a built-in cooling fan.
- Ensure the installation complies with all clearance requirements and applicable standards and regulations.
- Consult your local building authorities and by-laws if in doubt regarding the installation.
- To eliminate the risk of burns or fire by reaching over heated surface units, cabinet storage space located above the surface units should be avoided. If cabinet storage is to be provided, the risk can be reduced by installing a rangehood that projects horizontally a minimum of 127mm beyond the bottom of the overhead cabinets.

During installation, please ensure the following:

- Seal the exposed bare edges of the cutout with an oil-based paint or moisture-proof polyurethane to prevent possible moisture creeping between the cooktop trim and the benchtop.
- Take extreme care not to chip, crack, or break the top glass surfaces during installation. A heavy metal tool or part accidentally dropped on the glass could damage it.
- If, after following the instructions given, correct performance cannot be achieved, please contact your nearest Fisher & Paykel Service Centre, Customer Care, or contact us through our local website listed at the end of this document.

WARNING!

The owner carries all risk for flush mounting the cooktop. The owner must ensure the cooktop has been cut out from the countertop before servicing can be carried out. Fisher & Paykel will not be liable for any costs associated with removing or replacing a flush-mounted and/or sealed-in product, nor for repairing any damage that may be incurred by doing this.

PARTS SUPPLIED

MULTIPLE PRODUCT INSTALLATION

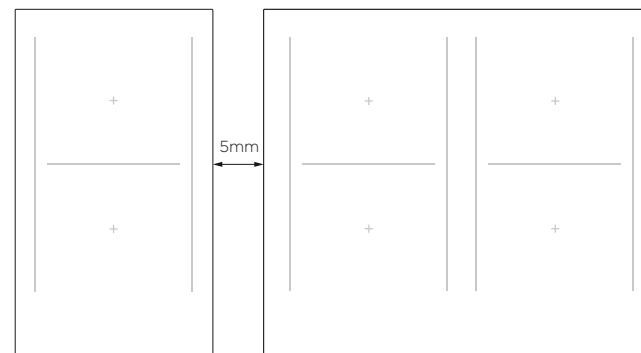

We recommend installing products in separate cutouts with a minimum distance of 5mm between the glass edges. If installing multiple products adjacent to each other within the same cutout, a separate joining strip kit is required for installation. The kit is available from the nearest Fisher & Paykel Authorised Service Centre or our website www.fisherpaykel.com.

If installing different products adjacent to each other (eg a wok burner next to an induction cooktop), the minimum clearance measurements for the different products may vary. Always use the greater distance.

COMPONENTS REQUIRED

PARTS SUPPLIED

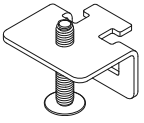

Clamping brackets
(4) and screws (4)
For CI302DTB only



Foam tape (1)

TOOLS REQUIRED

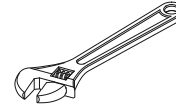

Wrench

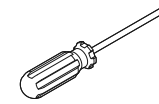

Crosshead
screwdriver



Silicone

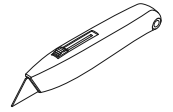

Cutter



Hex key

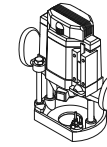

Router

PRODUCT DIMENSIONS – 300MM MODELS

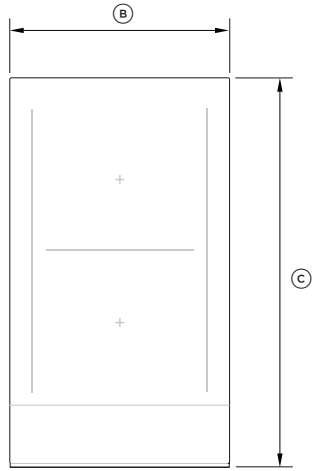

PLAN

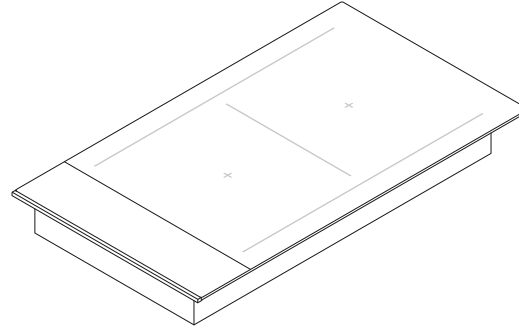

ISOMETRIC

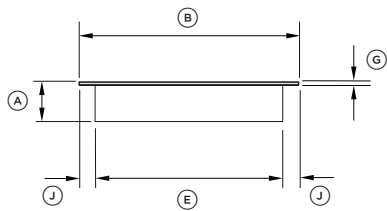

FRONT

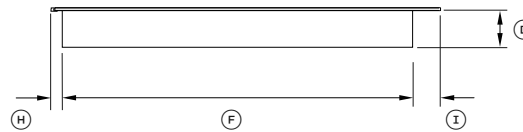

PROFILE

PRODUCT DIMENSIONS	CI302DTB
	MM
Ⓐ Overall height of cooktop	54
Ⓑ Overall width of cooktop	300
Ⓒ Overall depth of cooktop	530
Ⓓ Height of chassis	48
Ⓔ Width of chassis	260
Ⓕ Depth of chassis	480
Ⓖ Height of cooktop glass*	6
Ⓗ Depth of front overhang of cooktop glass**	13
Ⓘ Depth of rear overhang of cooktop glass	37
Ⓙ Depth of side overhang of cooktop glass	20

* Includes flange and tape

** Includes front trim

PRODUCT DIMENSIONS — 600MM MODEL

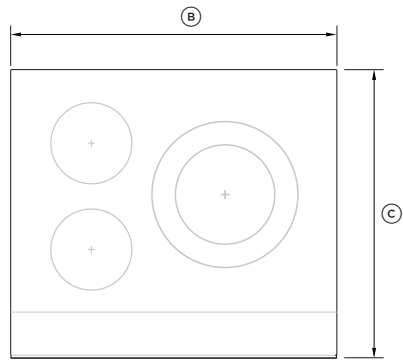

PLAN

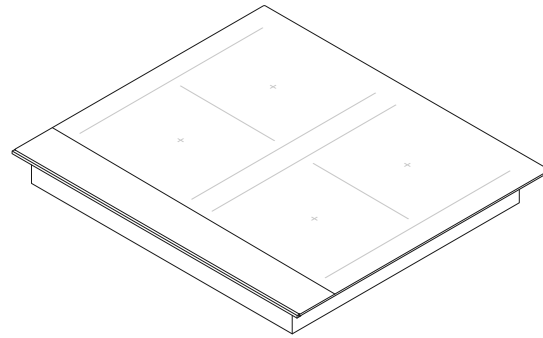

ISOMETRIC



FRONT

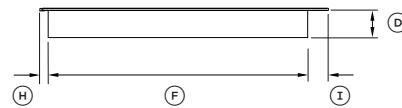

PROFILE

PRODUCT DIMENSIONS	CI603DTB	CI604DTB
	MM	MM
Ⓐ Overall height of cooktop	54	54
Ⓑ Overall width of cooktop	600	600
Ⓒ Overall depth of cooktop	530	530
Ⓓ Height of chassis	48	48
Ⓔ Width of chassis	552	552
Ⓕ Depth of chassis	480	480
Ⓖ Height of cooktop glass*	6	6
Ⓗ Depth of front overhang of cooktop glass**	13	13
Ⓘ Depth of rear overhang of cooktop glass	37	37
Ⓙ Depth of side overhang of cooktop glass	24	24

Illustrations show CI603DTB model cooktop.

* Includes flange and tape

** Includes front trim

PRODUCT DIMENSIONS — 760MM MODEL

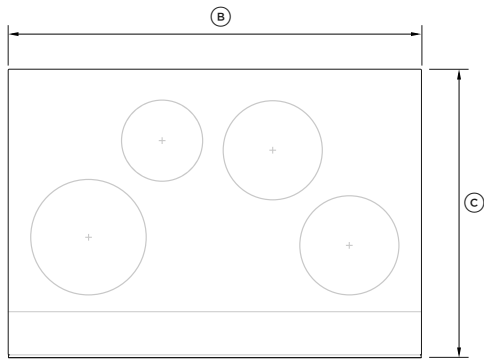

PLAN

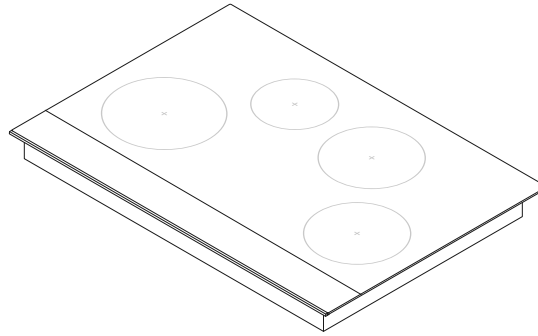

ISOMETRIC

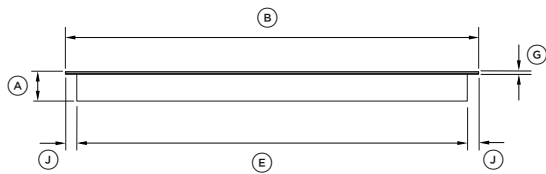

FRONT

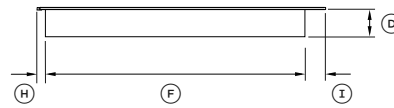

PROFILE

PRODUCT DIMENSIONS	CI764DTB
	MM
Ⓐ Overall height of cooktop	54
Ⓑ Overall width of cooktop	760
Ⓒ Overall depth of cooktop	530
Ⓓ Height of chassis	48
Ⓔ Width of chassis	722
Ⓕ Depth of chassis	480
Ⓖ Height of cooktop glass*	6
Ⓗ Depth of front overhang of cooktop glass**	13
Ⓘ Depth of rear overhang of cooktop glass	37
Ⓙ Depth of side overhang of cooktop glass	19

* Includes flange and tape

** Includes front trim

PRODUCT DIMENSIONS — 900MM MODEL

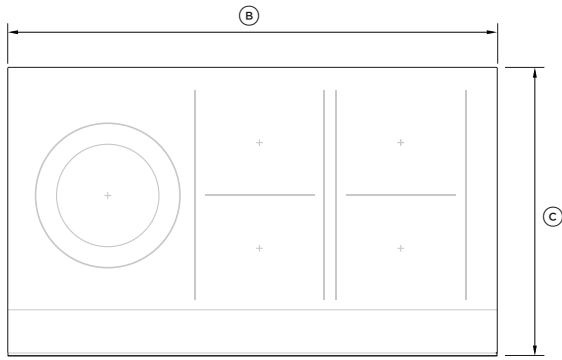

PLAN

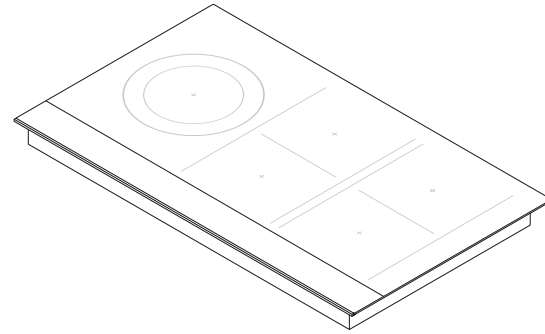

ISOMETRIC



FRONT

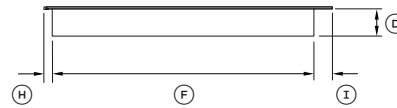

PROFILE

PRODUCT DIMENSIONS	C1905DTB
	MM
Ⓐ Overall height of cooktop	54
Ⓑ Overall width of cooktop	900
Ⓒ Overall depth of cooktop	530
Ⓓ Height of chassis	48
Ⓔ Width of chassis	858
Ⓕ Depth of chassis	484
Ⓖ Height of cooktop glass*	6
Ⓗ Depth of front overhang of cooktop glass**	13
Ⓘ Depth of rear overhang of cooktop glass	33
Ⓙ Depth of side overhang of cooktop glass	21

* Includes flange and tape

** Includes front trim

Actual product dimension may vary by ± 2 mm.

CUTOUT DIMENSIONS – 300MM MODEL

PROUD INSTALLATION

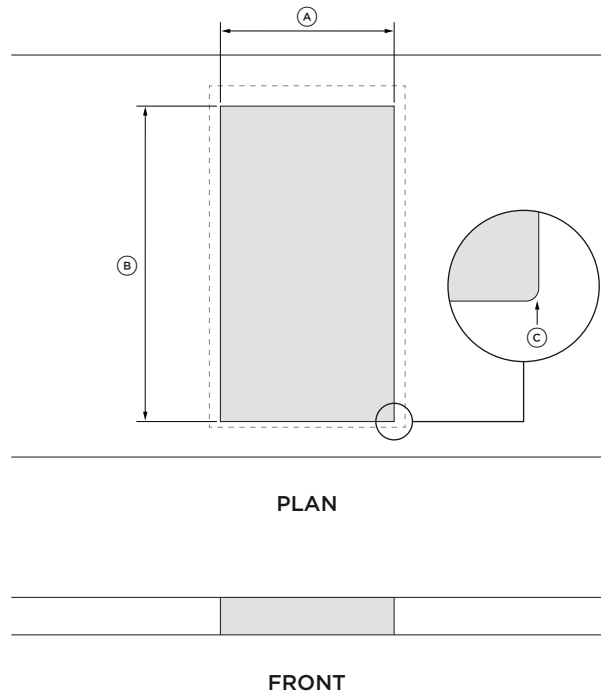

CI302DTB

MM

CUTOUT DIMENSIONS

Ⓐ Overall width of cutout	265
Ⓑ Overall depth of cutout	490
Ⓒ Corner radius of cutout	max 10

FLUSH INSTALLATION

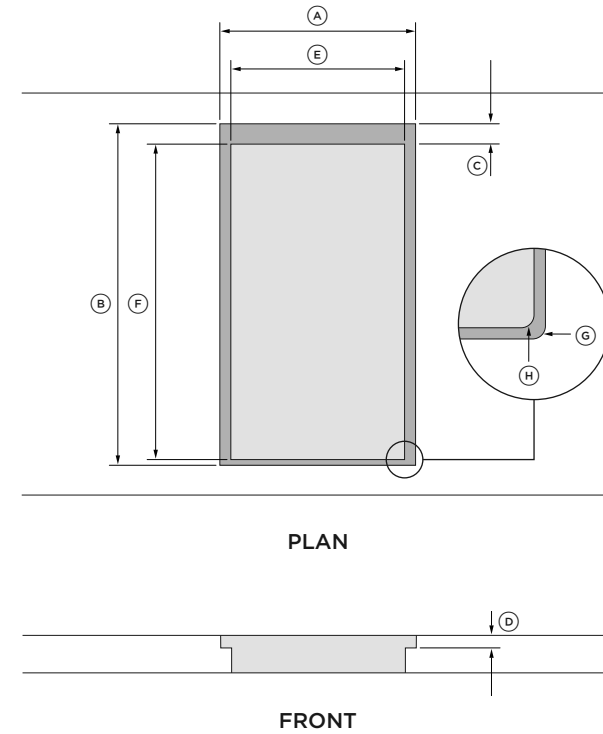

CI302DTB

MM

CUTOUT DIMENSIONS

Ⓐ Overall width of routed recess	305
Ⓑ Overall depth of routed recess	535
Ⓒ Offset overhang allowance	34
Ⓓ Height of routed recess	5
Ⓔ Width of cutout	265
Ⓕ Depth of cutout	490
Ⓖ Corner radius of routed recess	max 2
Ⓗ Corner radius of cutout	max 10

CUTOUT DIMENSIONS – 600MM MODEL

PROUD INSTALLATION

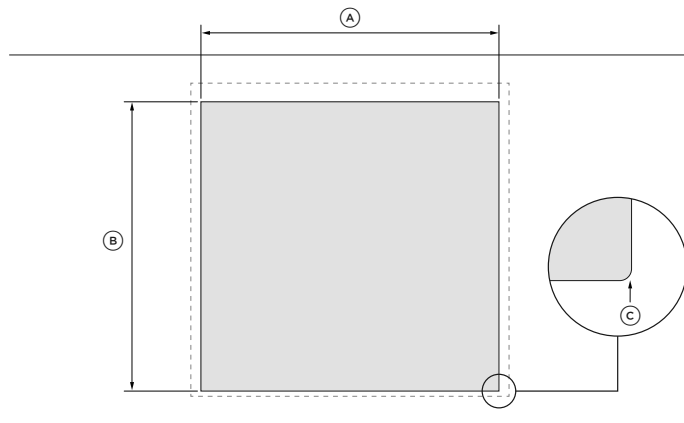

PLAN



FRONT

CUTOUT DIMENSIONS	C1603DTB	C1604DTB
	MM	MM
Ⓐ Overall width of cutout	560	560
Ⓑ Overall depth of cutout	490	490
Ⓒ Corner radius of cutout	max 10	max 10

FLUSH INSTALLATION

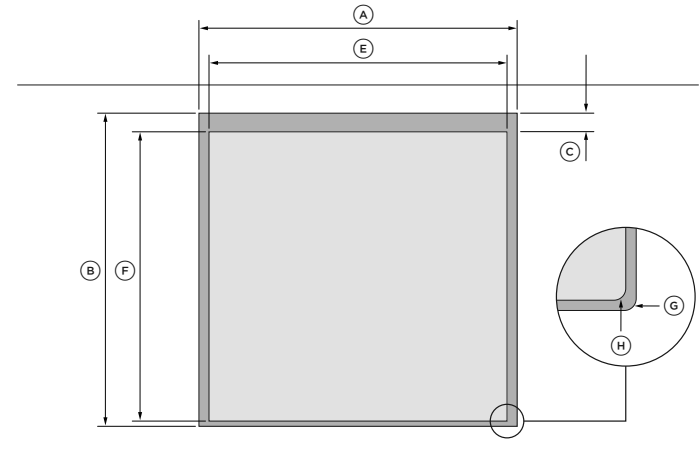

PLAN

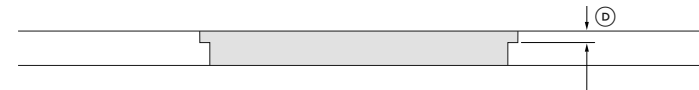

FRONT

CUTOUT DIMENSIONS	C1603DTB	C1604DTB
	MM	MM
Ⓐ Overall width of routed recess	605	605
Ⓑ Overall depth of routed recess	535	535
Ⓒ Offset overhang allowance	34	34
Ⓓ Height of routed recess	5	5
Ⓔ Width of cutout	560	560
Ⓕ Depth of cutout	490	490
Ⓖ Corner radius of routed recess	max 2	max 2
Ⓗ Corner radius of cutout	max 10	max 10

CUTOUT DIMENSIONS – 760MM MODEL

PROUD INSTALLATION

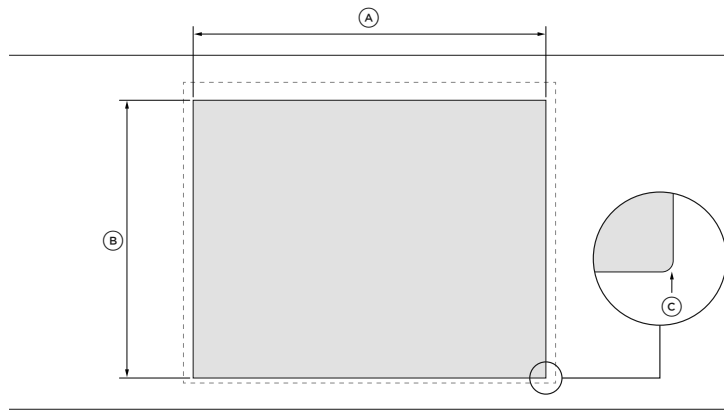

PLAN



FRONT

CUTOUT DIMENSIONS	CI764DTB
	MM
Ⓐ Overall width of cutout	725
Ⓑ Overall depth of cutout	490
Ⓒ Corner radius of cutout	max 10

FLUSH INSTALLATION

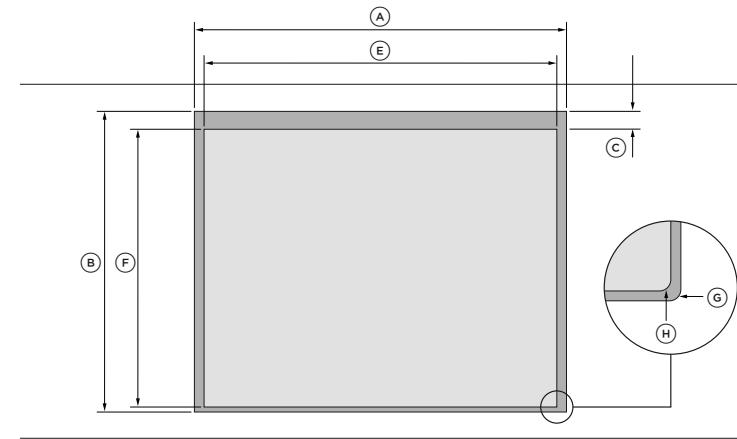

PLAN

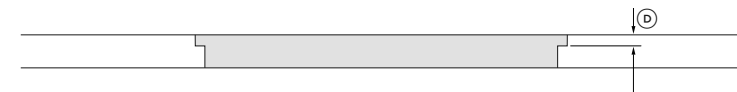

FRONT

CUTOUT DIMENSIONS	CI764DTB
	MM
Ⓐ Overall width of routed recess	765
Ⓑ Overall depth of routed recess	535
Ⓒ Offset overhang allowance	34
Ⓓ Height of routed recess	5
Ⓔ Width of cutout	725
Ⓕ Depth of cutout	490
Ⓖ Corner radius of routed recess	max 2
Ⓗ Corner radius of cutout	max 10

CUTOUT DIMENSIONS – 900MM MODEL

PROUD INSTALLATION

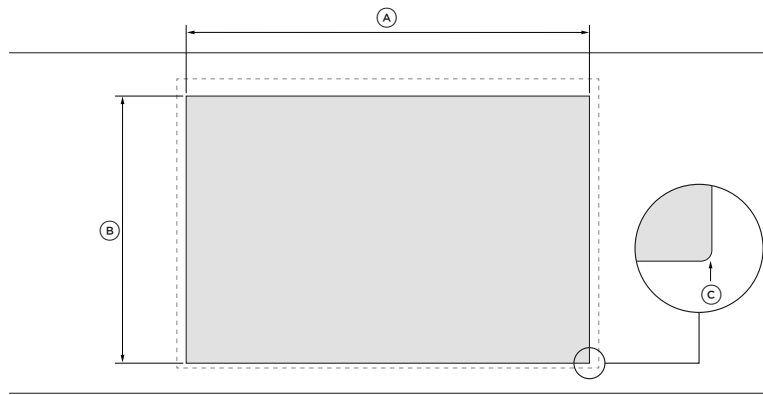

PLAN

FRONT

CUTOUT DIMENSIONS

CI905DTB

MM

Ⓐ Overall width of cutout	870
Ⓑ Overall depth of cutout	494
Ⓒ Corner radius of cutout	max 10

FLUSH INSTALLATION

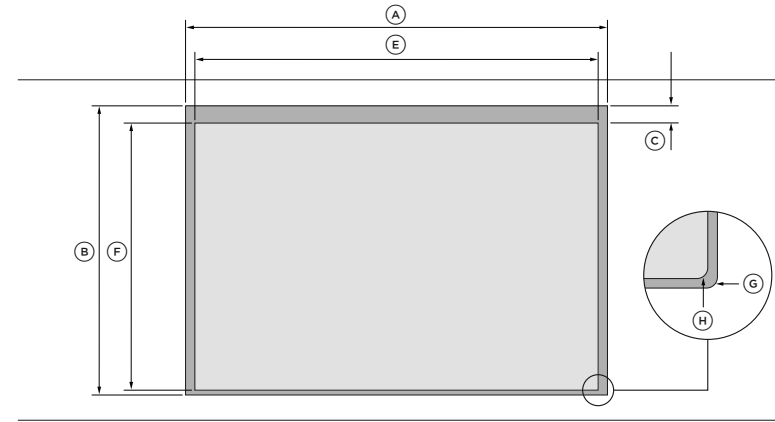

PLAN

FRONT

CUTOUT DIMENSIONS

CI905DTB

MM

Ⓐ Overall width of routed recess	905
Ⓑ Overall depth of routed recess	535
Ⓒ Offset overhang allowance	30
Ⓓ Height of routed recess	5
Ⓔ Width of cutout	870
Ⓕ Depth of cutout	494
Ⓖ Corner radius of routed recess	max 2
Ⓗ Corner radius of cutout	max 10

CLEARANCE DIMENSIONS – 300MM MODEL

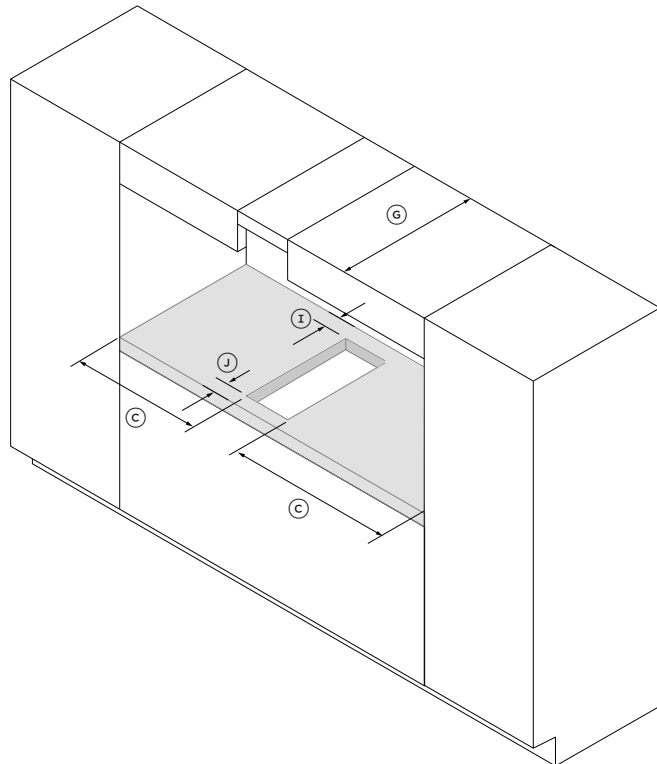
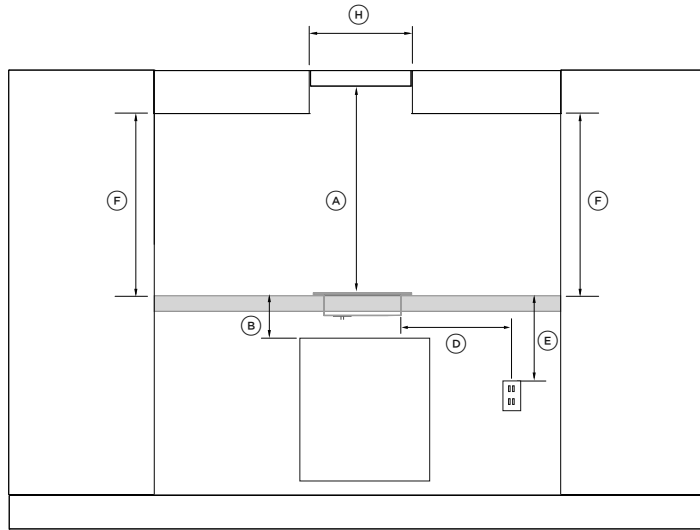

CLEARANCE DIMENSIONS	CI302DTB
	MM
Ⓐ Minimum clearance from glass surface to rangehood	650
Ⓑ Minimum clearance below top of countertop to top of any appliance, companion product or obstruction below cooktop	65
Ⓒ Minimum clearance from side edges of cutout to nearest combustible surface	30
Ⓓ Maximum distance from right edge of cutout to center of junction box	762
Ⓔ Minimum clearance below top of countertop to junction box	230
Ⓕ Minimum clearance from countertop to overhead cabinet (not directly above the cooktop)	450
Ⓖ Maximum depth of overhead cabinetry	330
Ⓗ Minimum distance between overhead cabinets (centered above the cooktop)	300
Ⓘ Minimum clearance from rear edge of cutout to nearest combustible surface	39
⓵ Minimum clearance from front edge of cutout to front edge of counter	35

CLEARANCE DIMENSIONS – 600MM MODEL

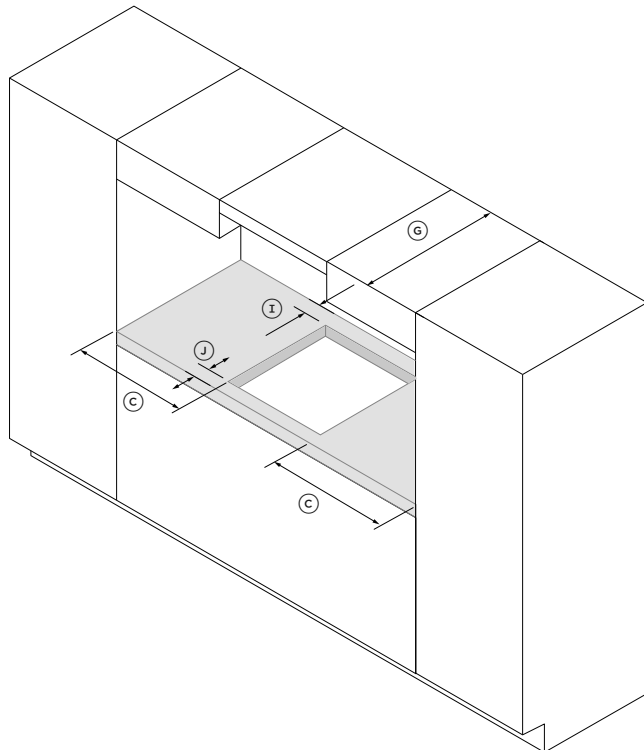
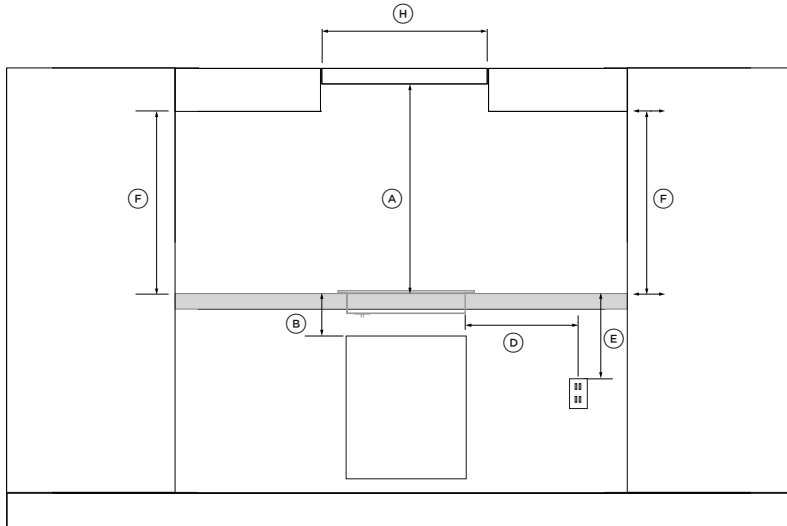

CLEARANCE DIMENSIONS	CI603DTB	CI604DTB
	MM	MM
Ⓐ Minimum clearance from glass surface to rangehood	650	650
Ⓑ Minimum clearance below top of countertop to top of any appliance, companion product or obstruction below cooktop	65	65
Ⓒ Minimum clearance from side edges of cutout to nearest combustible surface	30	30
Ⓓ Maximum distance from right edge of cutout to center of junction box	762	762
Ⓔ Minimum clearance below top of countertop to junction box	230	230
Ⓕ Minimum clearance from countertop to overhead cabinet (not directly above the cooktop)	450	450
Ⓖ Maximum depth of overhead cabinetry	330	330
Ⓗ Minimum distance between overhead cabinets (centered above the cooktop)	600	600
Ⓘ Minimum clearance from rear edge of cutout to nearest combustible surface	39	39
⓵ Minimum clearance from front edge of cutout to front edge of counter	35	35

CLEARANCE DIMENSIONS – 760MM MODEL

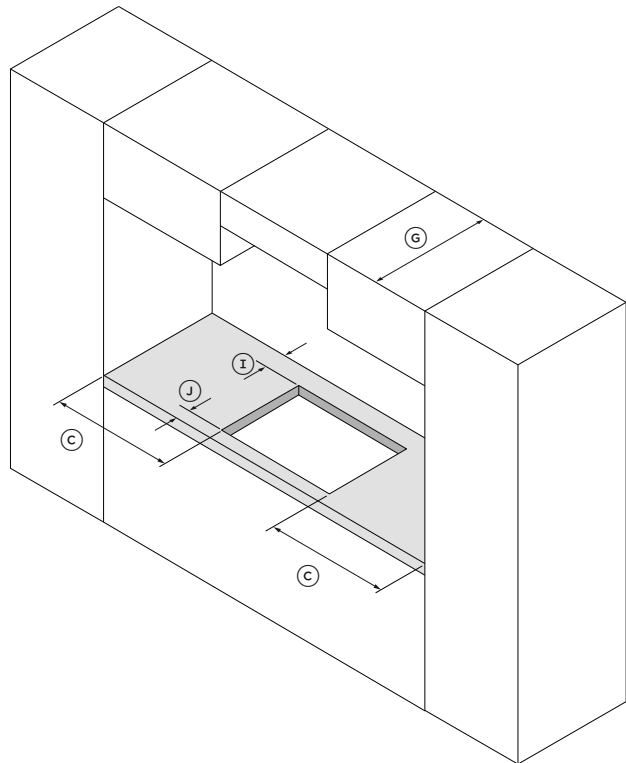
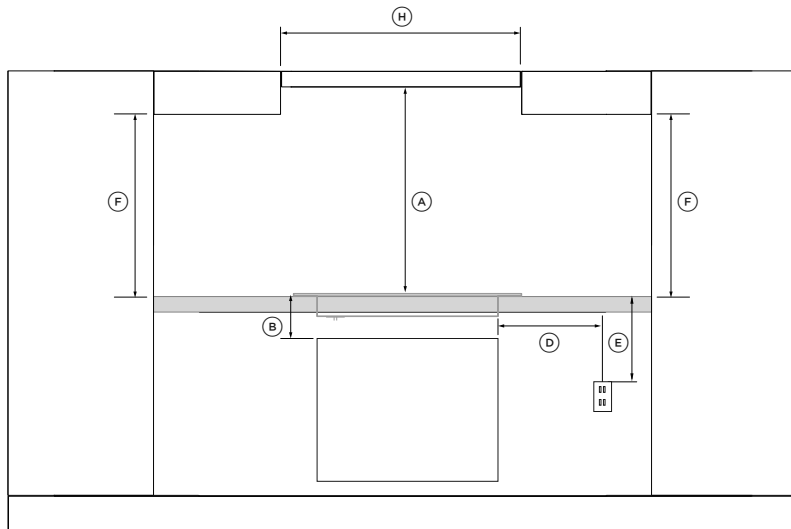

CLEARANCE DIMENSIONS	CI764DTB
	MM
Ⓐ Minimum clearance from glass surface to rangehood	650
Ⓑ Minimum clearance below top of countertop to top of any appliance, companion product or obstruction below cooktop	65
Ⓒ Minimum clearance from side edges of cutout to nearest combustible surface	30
Ⓓ Maximum distance from right edge of cutout to center of junction box	762
Ⓔ Minimum clearance below top of countertop to junction box	230
Ⓕ Minimum clearance from countertop to overhead cabinet (not directly above the cooktop)	450
Ⓖ Maximum depth of overhead cabinetry	330
Ⓗ Minimum distance between overhead cabinets (centered above the cooktop)	760
Ⓘ Minimum clearance from rear edge of cutout to nearest combustible surface	39
⓵ Minimum clearance from front edge of cutout to front edge of counter	35

CLEARANCE DIMENSIONS – 900MM MODEL

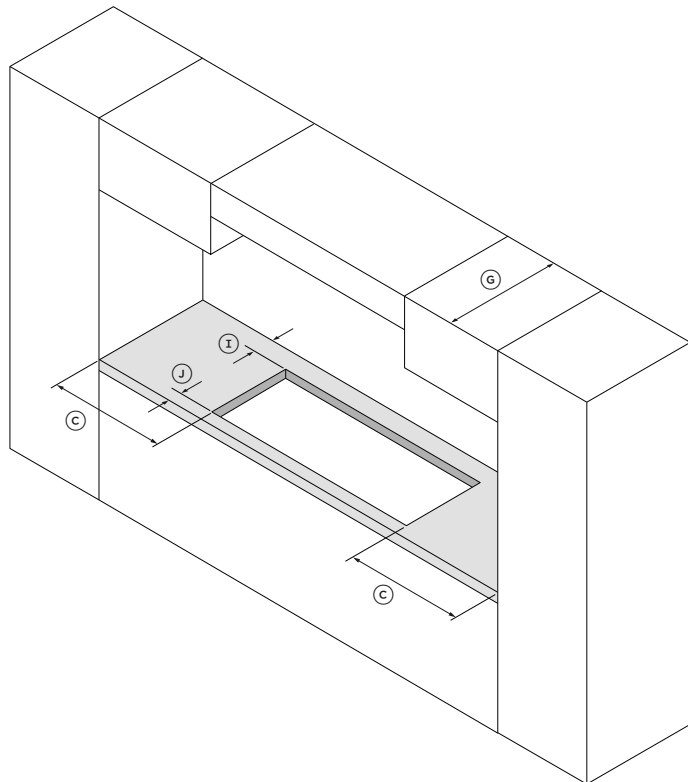
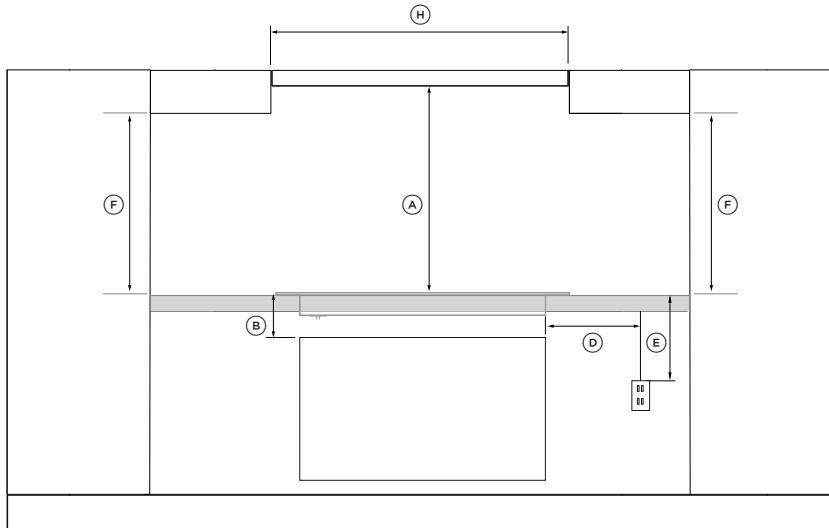

CLEARANCE DIMENSIONS	C1905DTB
	MM
Ⓐ Minimum clearance from glass surface to rangehood	650
Ⓑ Minimum clearance below top of countertop to top of any appliance, companion product or obstruction below cooktop	65
Ⓒ Minimum clearance from side edges of cutout to nearest combustible surface	30
Ⓓ Maximum distance from right edge of cutout to center of junction box	762
Ⓔ Minimum clearance below top of countertop to junction box	230
Ⓕ Minimum clearance from countertop to overhead cabinet (not directly above wwtthe cooktop)	450
Ⓖ Maximum depth of overhead cabinetry	330
Ⓗ Minimum distance between overhead cabinets (centered above the cooktop)	900
Ⓘ Minimum clearance from rear edge of cutout to nearest combustible surface	35
⓵ Minimum clearance from front edge of cutout to front edge of counter	35

VENTING CLEARANCES

DRAWER OR OTHER OBSTRUCTION

This cooktop requires adequate supply of cool air to fully function. The base of the cooktop must have direct unrestricted ventilation to the room where the cooktop is installed. There must be a 4mm air gap at the front of the cooktop.

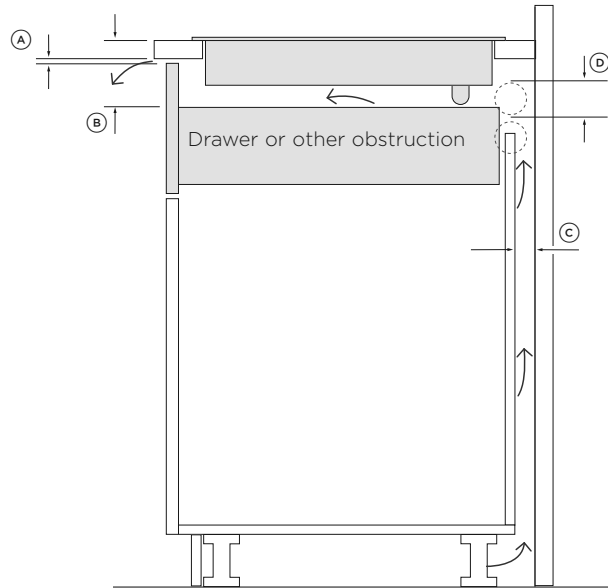

CLEARANCE DIMENSIONS	MM
Ⓐ Minimum ventilation gap at the front of the cooktop	4
Ⓑ Minimum clearance from cooktop to drawer or other obstruction	65
Ⓒ Minimum ventilation gap at the rear of the cooktop	20
Ⓓ Minimum diameter of cooling air hole	50

OVEN WITH COOLING FAN

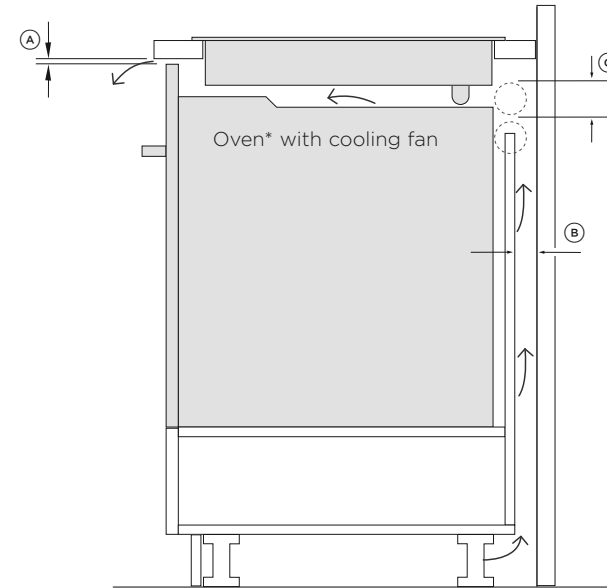

CLEARANCE DIMENSIONS	MM
Ⓐ Minimum ventilation gap at the front of the cooktop	4
Ⓑ Minimum ventilation gap at the rear of the cooktop	20
Ⓒ Minimum diameter of cooling air hole	50

*Some ovens require installation in a sealed box. Please refer you oven installation guide for more information.

PROUD INSTALLATION

1

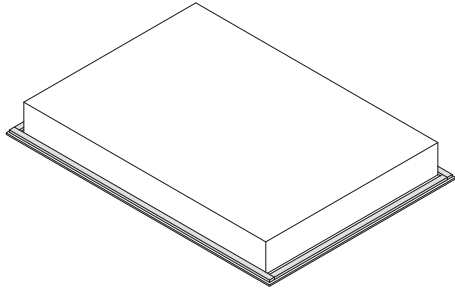

Turn the cooktop upside down on a protective cover.

2

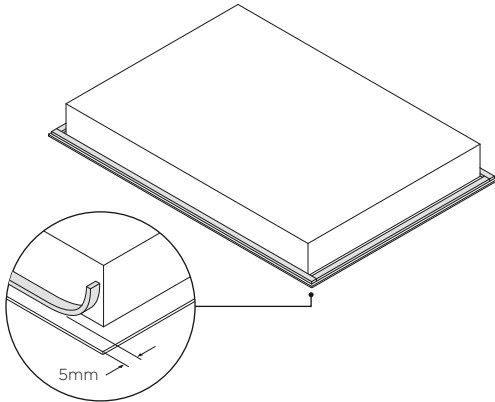

Apply adhesive foam seal around the glass overhang, 5mm from the edge of the glass.
Ensure the adhesive side facing is down to form a continuous seal around the cooktop.

3

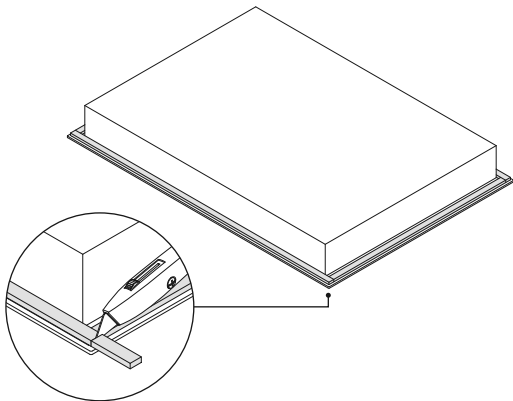

Trim the excess sealing material using a sharp cutter or trimmer knife.
Take care not to damage the benchtop.

4

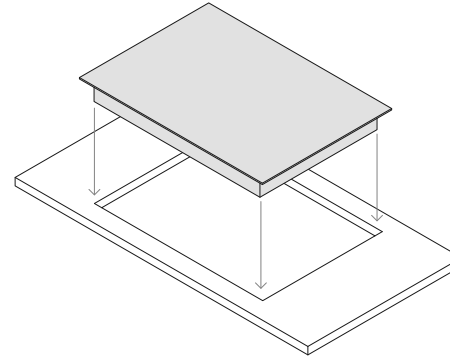

Gently lower the cooktop into the cutout ensuring you have access below the countertop to fit and secure the brackets.

5

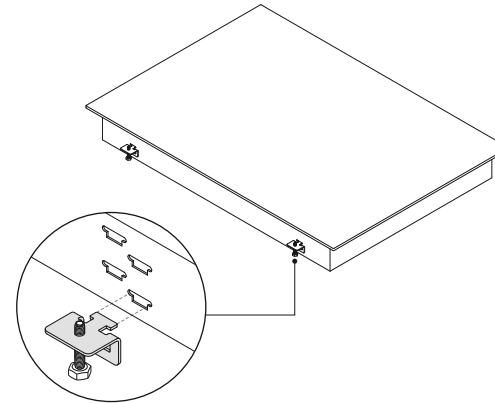

Locate the side brackets* to the appropriate slots on the cooktop chassis. The correct slot height is determined by the thickness of your countertop.

6

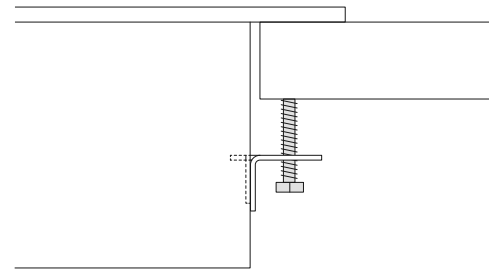

Tighten all screws to secure the cooktop to the countertop.
Ensure cooktop is level.

*The number of brackets varies based on your cooktop model.

FLUSH INSTALLATION

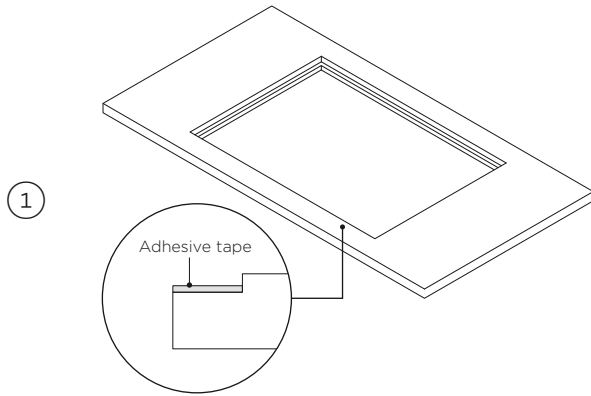

Prepare the countertop for flush installation. Use a router to cut out the edges of the countertop to specified depth (5mm). Attach an adhesive tape along the edges of the routed recess.

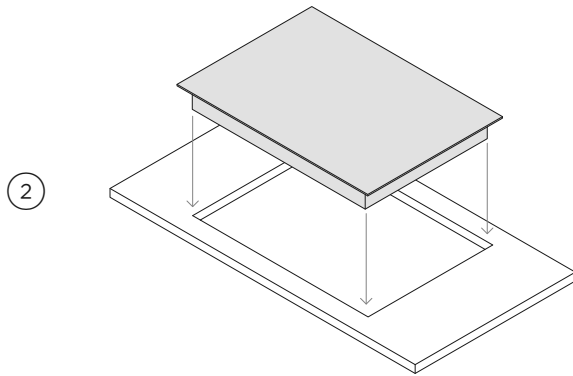

Gently lower the cooktop into the cutout ensuring you have access below the countertop to fit and secure the brackets.

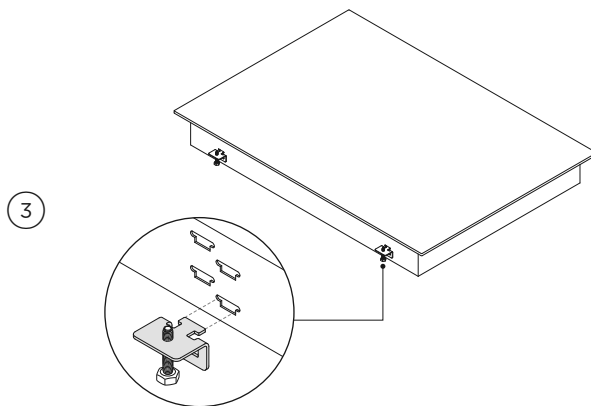

Locate the side brackets* to the appropriate slots on the cooktop chassis. The correct slot height is determined by the thickness of your countertop.

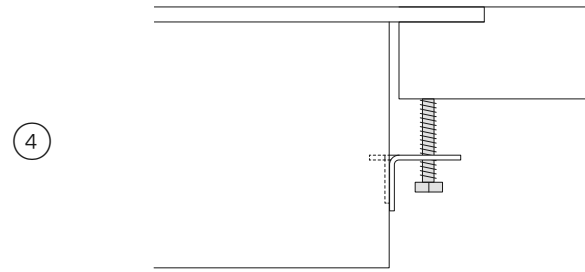

Tighten all screws to secure the cooktop to the countertop. Ensure cooktop is level.

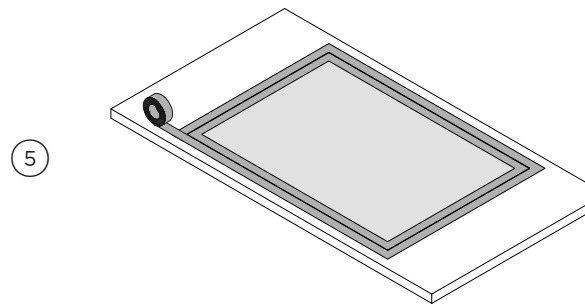

Mask off the area to be siliconed ensuring both the cooktop and countertop are protected.

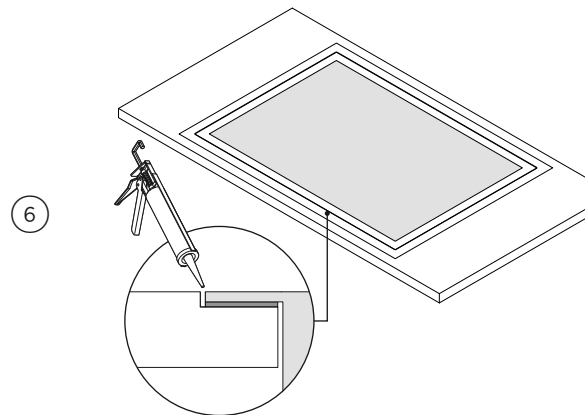

Apply silicone in the gap between benchtop and cooktop. Wipe off excess silicone.

ELECTRICAL CONNECTION

Before connecting the cooktop to the mains power supply check that:

- The domestic wiring system is suitable for the power drawn by the cooktop.
- The voltage corresponds to the value given in the rating plate.
- The power supply cable sections can withstand the load specified on the rating plate.

MODEL	MAX. CURRENT DRAW	MAX. LOAD	VOLTAGE
CI302DTB*	16A	3700W	220-240V ~
CI603DTB	32A	7050W	220-240V 2N ~ 380-415V 2N ~
CI604DTB	32A	7050W	220-240V 2N ~ 380-415V 2N ~
CI764DTB	32A	7400W	220-240V 2N ~ 380-415V 2N ~
CI905DTB	43A	9800W	220-240V 3N ~ 380-415V 3N ~

*The CI302DTB is supplied with a cable. This must be wired into a suitably rated plug, permanent connection outlet or power isolator.

..... CI302DTB, CI603DTB, CI604DTB, CI754DTB & CI764DTB MODELS

Single-phase connection
220-240V~

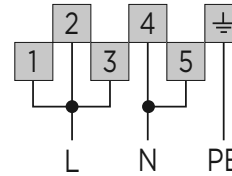

Two-phase connection
380-415V 2N~

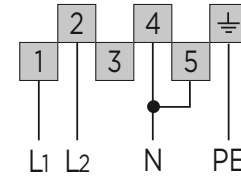

Three-phase connection
380-415V 3N~

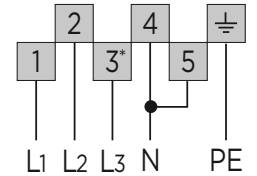

*Not Internally connected

..... CI905DTB MODELS

Single-phase connection
220-240V~

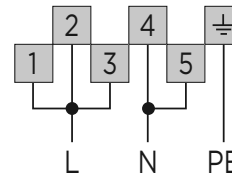

Two-phase connection
380-415V 2N~

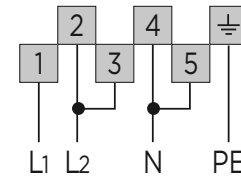

Three-phase connection
380-415V 3N~

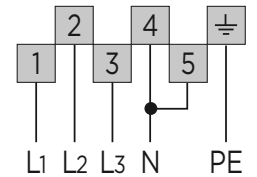

INSTALLER CHECKLIST

TO BE COMPLETED BY THE INSTALLER

GENERAL

- Read safety and warnings in the user guide before operating the cooktop.
- Specified clearance maintained.
- Unit is level – front to back and side to side.
- All packaging materials have been removed.
- There is constant flow of cool air from the cabinetry to the base of the cooktop.
- Cooktop is securely clamped.
- Basic operation has been demonstrated to the customer.
- Cooking zones are functioning correctly. Turn on all of them to a high setting and leave them on for at least one minute.
- Touch controls and displays are functioning.

ELECTRICAL

- Receptacle with correctly rated over-current protection is provided for service cord connection.
- Adequate ground connection.
- Power supply cable is accessible and is not touching the cooktop.

Complete and keep for safe reference:

Model _____

Serial No. _____

Purchase Date _____

Purchaser _____

Dealer Address _____

Installer's Name _____

Installer's Signature _____

Installation Company _____

Installation Date _____

FISHERPAYKEL.COM

© Fisher & Paykel Appliances 2023. All rights reserved.

The models shown in this guide may not be available in all markets
and are subject to change at any time.

The product specifications in this guide apply to the specific products and
models described at the date of issue. Under our policy of continuous product
improvement, these specifications may change at any time.

For current details about model and specification availability in your country,
please go to our website or contact your local Fisher & Paykel dealer.

592132D 02.23