

FABRIC CARE

PLANNING GUIDE

Series 7 Front Loader Washer | WH1260R5

Series 7 Heat Pump Dryer | DH1060R5

Stacking Kit with Tray | ASKS60W5

FISHER & PAYKEL

INTRODUCTION

This comprehensive planning guide provides you with the framework and tools to achieve your desired design outcome with Fisher & Paykel appliances. In this guide, you will find a range of conceptual, detailed, and dimensional product information to bring your ideas to life and create spaces that truly reflect your vision.

SUPPORT

For additional design planning and installation support please contact the Fisher & Paykel design support team.
designsupport@fisherpaykel.com

NOTES

The models shown in this Planning Guide may not be available in all markets and are subject to change at any time. For the latest version of this document, please visit our website at fisherpaykel.com. Product specifications may vary from those shown.

This Planning Guide is not intended to be used as installation guidance for any product. Detailed installation instructions are available on our website.

CONTENTS

CONCEPT DESIGN

PAGE

PRODUCT OVERVIEW

Product Overview **4**

SPECIFICATION GUIDE

Fabric Care - All Models **6**

Front Loader Washer **7**

Heat Pump Dryer **8**

DEVELOPED AND DETAILED DESIGN

PAGE

DATA SHEETS

WH1260R5 **10**

DH1060R5 **11**

ASKS60W5 **12**

CONFIGURATIONS

Side by side **14**

Stacked **15**

DEVELOPED AND DETAILED DESIGN

PAGE

SERVICES

Front loader washer **17**

Heat pump dryer **18**

Side by side - washer and dryer **19**

Stacked - washer and dryer **20**

PRODUCT OVERVIEW

PRODUCT OVERVIEW

Series 7 Front Loader Washers

| | | | |
|----------|----------|------|-----------------------------|
| 1 | WH1260R5 | 12kg | White with black glass door |
|----------|----------|------|-----------------------------|

Series 7 Front Loader Heat Pump Dryer

| | | | |
|----------|----------|------|-----------------------------|
| 2 | DH1060R5 | 10kg | White with black glass door |
|----------|----------|------|-----------------------------|

Accessories overview

| | | |
|----------|----------|---------------------|
| 3 | ASKS60W5 | Stacking Kit, White |
|----------|----------|---------------------|

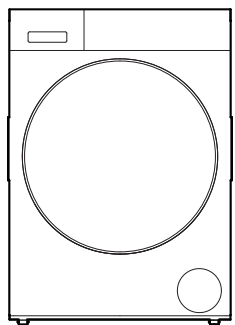

①

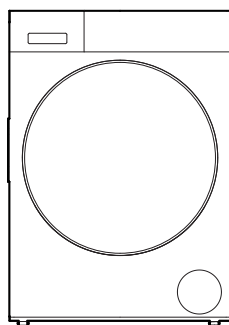

②

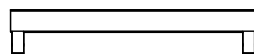

③

The models shown in this Planning Guide may not be available in all markets and are subject to change at any time. For the latest version of this document, please visit our website at fisherpaykel.com. Product specifications may vary from those shown. The Planning Guide is not intended to be used as installation guidance for any product. Detailed installation instructions are available on our website.

SPECIFICATION GUIDE



OVERVIEW

Elevating beyond the utility space, our Fabric Care Solutions pair sleek design and refined materials with advanced technology. Front Loader Washing Machines powered by SmartDrive™ deliver quieter operation, while Heat Pump Dryers with intelligent compressor control and moisture sensing provide efficient, gentle drying. With a vivid display, intuitive controls make caring for fibres effortless. Installed side-by-side, or stacked with a Stacking Kit, their aligned proportions and pared-back interfaces bring a cohesive, considered aesthetic to the laundry space or create harmony in wardrobes, mudrooms, and entryways.

FEATURES

- 1 The sleek modern design, large glass door and carefully selected materials elevate our Fabric Care Solutions beyond the utility space. Thoughtfully designed to harmonise with surrounding finishes, they enhance wardrobes, mudrooms, and entryways with a refined, considered presence.
- 2 Front Loader Washing Machines and Heat Pump Dryers are designed as a true pair, with aligned proportions, finishes, and controls. Install them side-by-side or stacked with the Stacking Kit.
- 3 Interfaces and detailing are paired back to achieve a clean, minimal presentation. This reduction in visual noise helps appliances blend into design-led environments, supporting calm and considered interiors.
- 4 Powered by SmartDrive™ and ActiveIntelligence™ technology, Front Loader Washing Machines deliver quiet operation with few moving parts, plus clever load size and soil sensing for perfect results. This makes them well suited to placement in open-plan areas or wardrobes, where a low-noise environment is important.
- 5 Heat Pump Dryer technology with precise temperature control and moisture sensing delivers efficient yet gentle drying. Intelligent compressor technology adjusts drying temperatures to suit each fibre's durability, while specialised tumble patterns ensure optimal care and cycle times.
- 6 The 5" colour touchscreen display provides a clear, modern interface to guide users through cycle selection with ease. This intuitive control makes it simple to care for fibres from soft Silk and delicate Down to Woolmark Black certified Wool.
- 7 Steam Refresh and Sanitise reduce reliance on dry-cleaning by refreshing garments quickly and safely at home.
- 8 FlexiDose Auto-Dosing protects fibres and prevents waste by dispensing the perfect amount of detergent and softer for every load. With two reservoirs, one for detergent and the other for softener, which can also hold extra detergent if required.
- 9 Designed to reduce running costs and environmental impact with highly efficient energy and water ratings, delivering an effective and sustainable fabric care routine.
- 10 Haier Smart Home app compatibility enables remote monitoring, notifications when cycles are complete, and software updates when new cycles and feature enhancements are available.

The models shown in this Planning Guide may not be available in all markets and are subject to change at any time. For the latest version of this document, please visit our website at fisherpaykel.com. Product specifications may vary from those shown. The Planning Guide is not intended to be used as installation guidance for any product. Detailed installation instructions are available on our website.

SPECIFICATIONS

Model Number

WH1260R5 12kg Front Loader Washer, White

Product Dimensions

H 850mm W 602mm D 661mm

Electrical

Supply 220 VAC, 50 Hz

Service 10 A

Connection 3-pole plug with grounding

Plumbing

Supply Hose set provided

Service Max. 1MPa; Min. 30KPa
Min 6 litres/min

PRODUCT DIMENSIONS

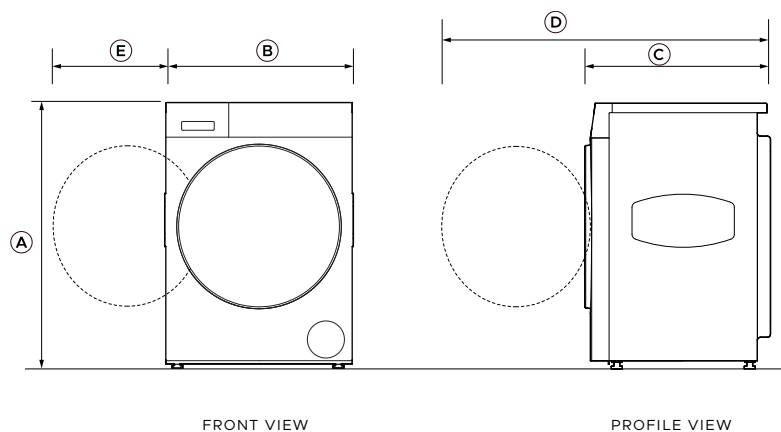

CAVITY DIMENSIONS

| | mm | | mm |
|--|---------|--|-----|
| A Overall height | 850 | A Minimum height | 865 |
| Height of adjustable mounted feet | max +10 | B Minimum width | 622 |
| B Overall width including chassis form | 602 | C Minimum depth | 668 |
| Overall width front panel | 592 | Minimum visual gap to adjacent cabinetry from product* | 15 |
| C Overall depth* | 661 | | |
| D Depth with the door open | 1146 | | |
| E Door clearance to adjacent wall | 267 | | |

*Includes door when closed

*Applies to sides and top

The models shown in this Planning Guide may not be available in all markets and are subject to change at any time. For the latest version of this document, please visit our website at fisherpaykel.com. Product specifications may vary from those shown. The Planning Guide is not intended to be used as installation guidance for any product. Detailed installation instructions are available on our website.

SPECIFICATIONS

Model Number

DH1060R5 10kg Heat Pump Dryer, White

Product Dimensions

H 850mm W 602mm D 682mm

Electrical

Supply 220 VAC, 50 Hz

Service 10 A

Connection 3-pole plug with grounding

Plumbing

Supply Hose set provided

Service Max. 1MPa; Min. 30KPa
Min 6 litres/min

PRODUCT DIMENSIONS

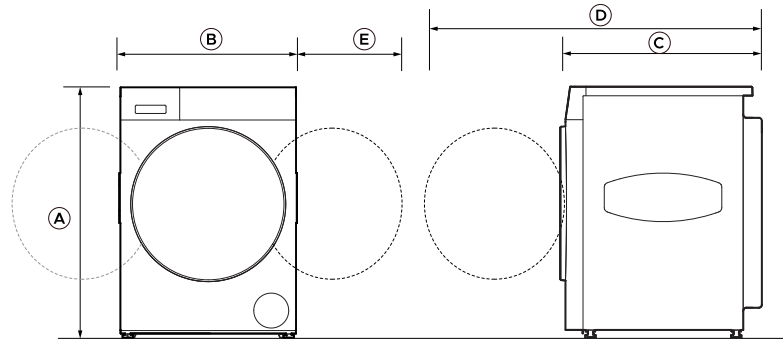

FRONT VIEW

PROFILE VIEW

CAVITY DIMENSIONS

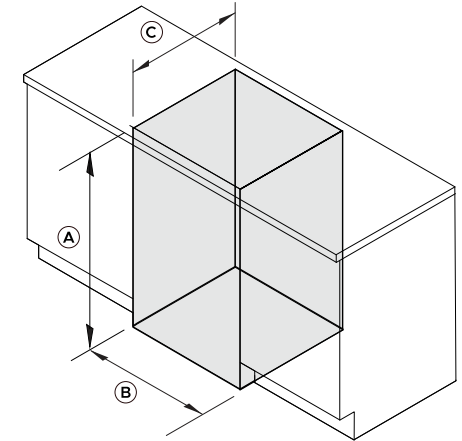

ISOMETRIC VIEW

| | mm | | mm |
|--|------------------|--|-----|
| A Overall height | 850 | A Minimum height | 865 |
| Height of adjustable mounted feet | min -5 max +5 | B Minimum width | 622 |
| B Overall width including chassis form | 602 | C Minimum depth | 688 |
| Overall width front panel | 592 | Minimum visual gap to adjacent cabinetry from product* | 15 |
| C Overall depth* | 682 | *Applies to sides and top | |
| D Depth with the door open | 1167 | | |
| E Door clearance to adjacent wall | 267 | | |

*Includes door when closed

The models shown in this Planning Guide may not be available in all markets and are subject to change at any time. For the latest version of this document, please visit our website at fisherpaykel.com. Product specifications may vary from those shown. The Planning Guide is not intended to be used as installation guidance for any product. Detailed installation instructions are available on our website.

DATA SHEETS

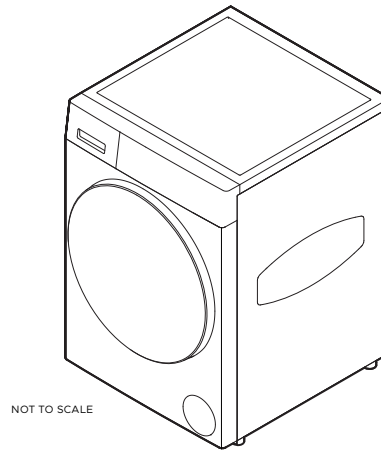
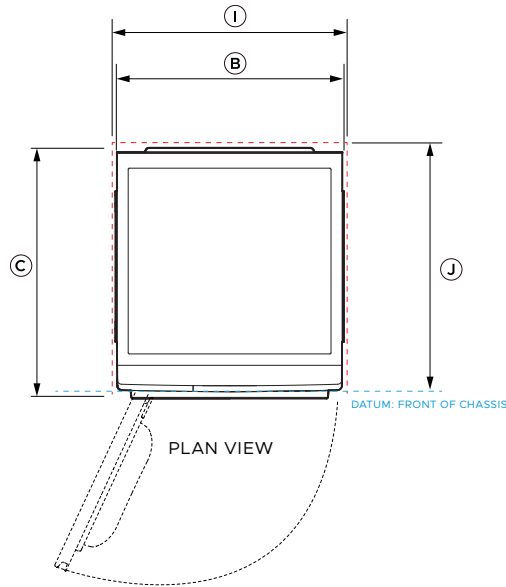

ISOMETRIC VIEW

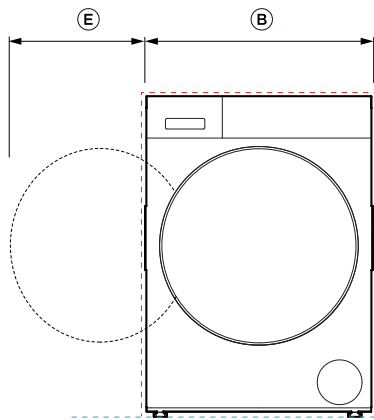

FRONT VIEW

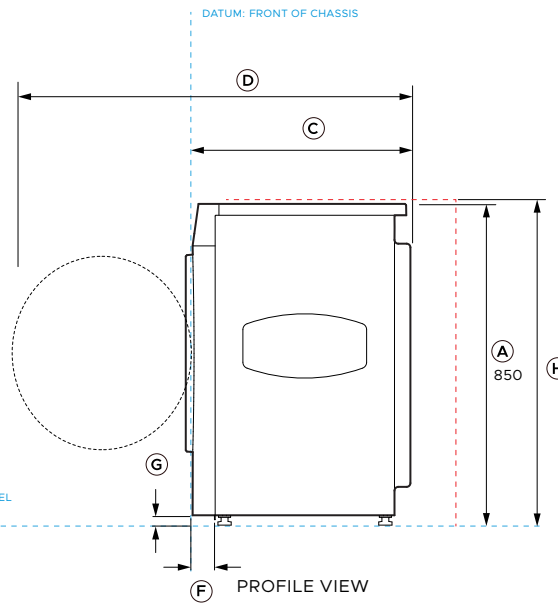

PROFILE VIEW



Model no:
WH1260R5

| Product Dimensions | | mm |
|--------------------|---------------------------------------|-------------------|
| A | Overall height | 850 |
| B | Overall width including chassis form | 602 |
| | Overall width excluding chassis form | 595 |
| | Overall width front panel | 592 |
| C | Overall depth | 661 |
| D | Depth with the door open | 1146 |
| E | Door clearance to adjacent wall | min 267 |
| F | Overall depth of finished front panel | 55 |
| G | Height of adjustable mounted feet | min -5 max +10 |

| Cavity Dimensions: Standard Installation | | mm |
|--|---|-----|
| H | Minimum height of cavity* | 865 |
| I | Minimum width of cavity | 622 |
| J | Minimum overall cavity depth Flush with front panel of the chassis | 668 |
| | Minimum gap clearance to adjacent product or cabinetry** | 10 |
| | Minimum visual gap to adjacent cabinetry and product | 15 |

* Depends on feet adjustment
** Applies to sides and top

----- INDICATES CABINETY / PRODUCT DATUM
- - - - - INDICATES CABINETY CLEARANCES
- - - - - INDICATES CUTOUT

IMPORTANT NOTE: Throughout this guide, dimensions may vary by +/- 2mm (1/16"). Please read the installation manual for detailed information on installing the product. For full installation instructions & specifications visit fisherpaykel.com

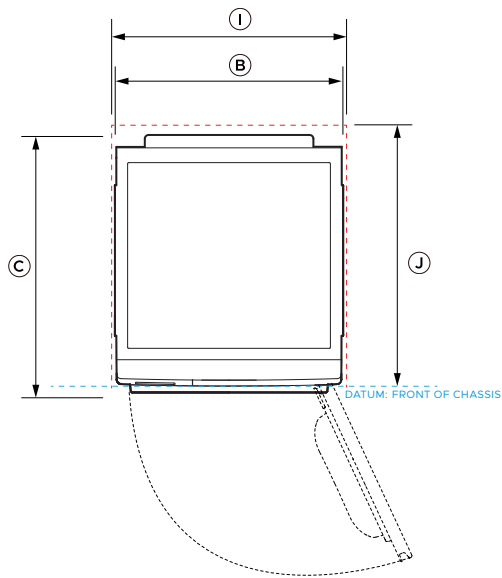

PLAN VIEW

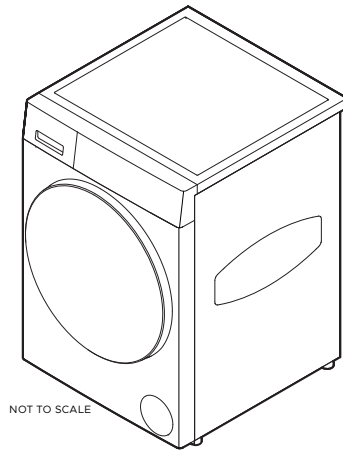

ISOMETRIC VIEW

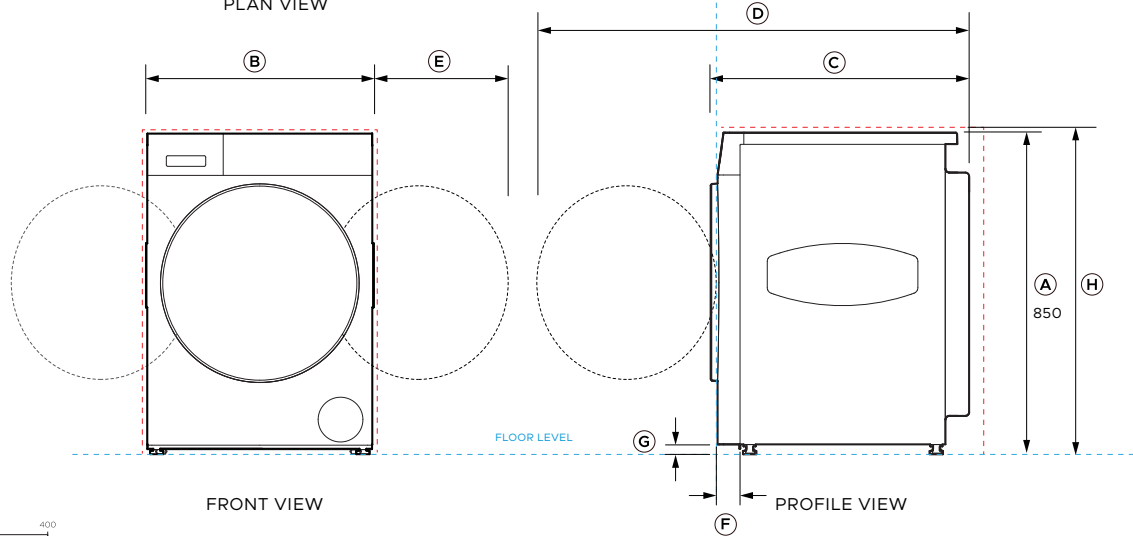

FRONT VIEW

PROFILE VIEW



Model no:

DH1060R5

Product Dimensions

| | mm |
|---|------------------|
| A Overall height | 850 |
| B Overall width including chassis form | 602 |
| Overall width excluding chassis form | 595 |
| Overall width front panel | 592 |
| C Overall depth | 682 |
| D Depth with the door open*** | 1167 |
| E Door clearance to adjacent wall | min 267 |
| F Overall depth of finished front panel | 55 |
| G Height of adjustable mounted feet | min -5 max +5 |

Cavity Dimensions: Standard Installation

| | mm |
|--|-----|
| H Minimum height of cavity* | 865 |
| I Minimum width of cavity | 622 |
| J Minimum overall cavity depth | 688 |
| Minimum gap clearance to adjacent product or cabinetry** | 10 |
| Minimum visual gap to adjacent cabinetry and product | 15 |

* Depends on feet adjustment

** Applies to sides and top

***Dryer door hinge is reversible

----- INDICATES CABINETRY / PRODUCT DATUM

----- INDICATES CABINETRY CLEARANCES

----- INDICATES CUTOUT

IMPORTANT NOTE: Throughout this guide, dimensions may vary by +/- 2mm (1/16"). Please read the installation manual for detailed information on installing the product. For full installation instructions & specifications visit fisherpaykel.com

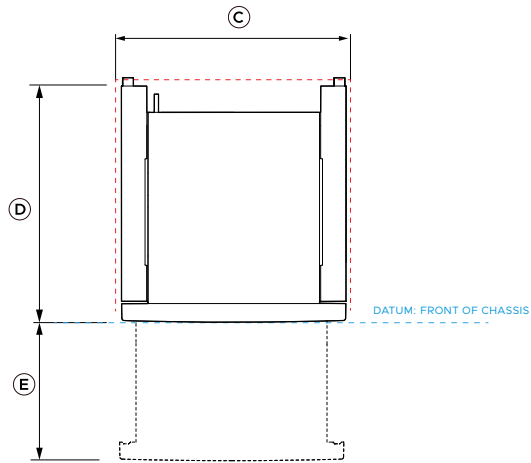

PLAN VIEW

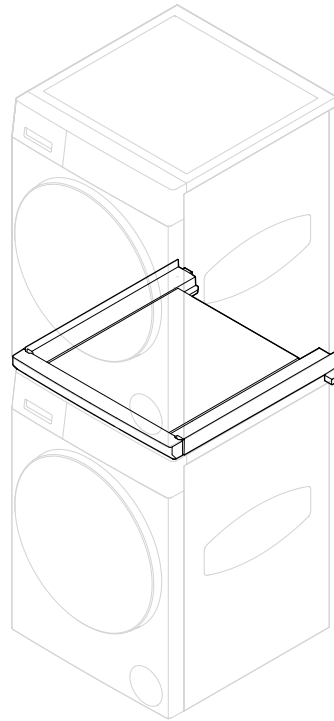

ISOMETRIC VIEW

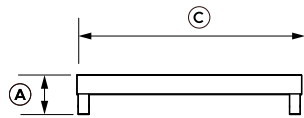

FRONT VIEW

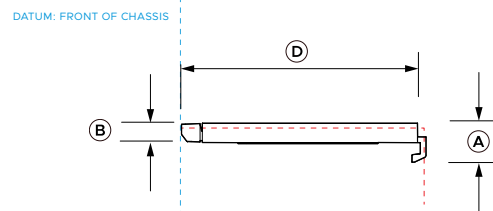

PROFILE VIEW



Model no:

Stacking kit ASKS60W5

Product Dimensions

| | mm |
|------------------|-----------|
| A Overall height | 104 |
| B Shelf height | 52 |
| C Overall width | 595 |
| D Overall depth | 648 |
| E Tray extension | 405 |

----- INDICATES CABINETY / PRODUCT DATUM
 - - - - - INDICATES CABINETY CLEARANCES
 - - - - - INDICATES CUTOUT

IMPORTANT NOTE: Throughout this guide, dimensions may vary by +/- 2mm (1/16"). Please read the installation manual for detailed information on installing the product. For full installation instructions & specifications visit fisherpaykel.com

CONFIGURATIONS

Washing Machine

WH1260R5* White

Heat Pump Dryer

DH1060R5** White

*Left Hand Hinge

**Right Hand Hinge (Dryer hinges can be reversed)

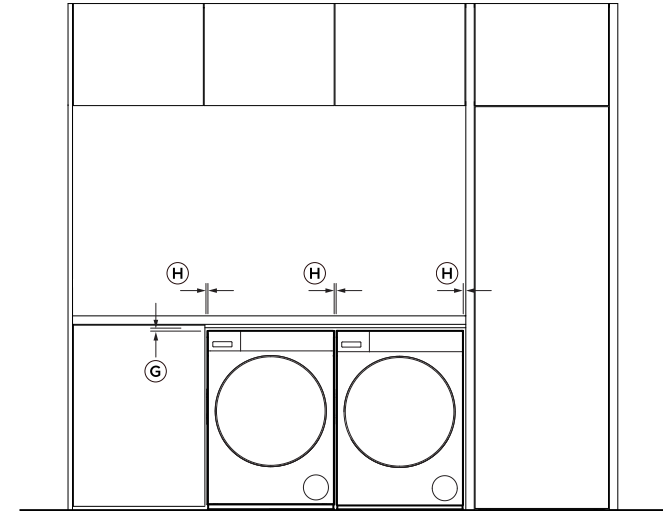
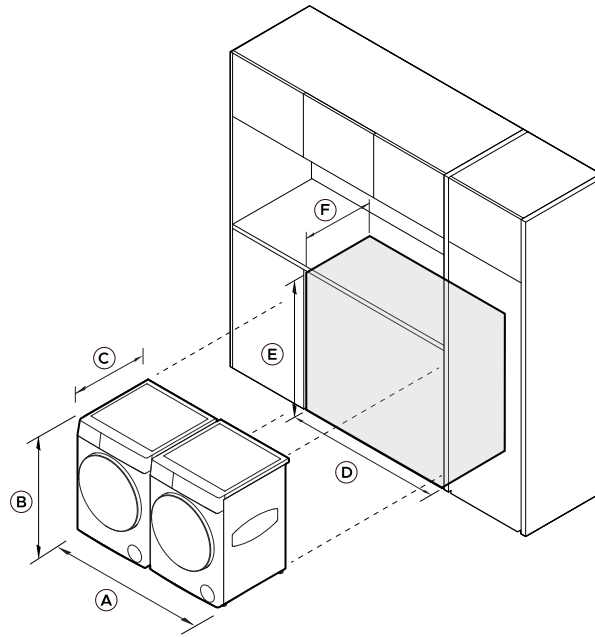

| PRODUCT DIMENSIONS | |
|---|------|
| | mm |
| A Overall products width Washer and Dryer* | 1200 |
| B Overall product height Washer and Dryer | 850 |
| C Overall product depth Washer and Dryer | 682 |
| * Washer and Dryer width exclude the chassis form | |

| CAVITY DIMENSIONS | |
|-------------------------|------|
| | mm |
| D Overall cavity width | 1234 |
| E Overall cavity height | 865 |
| F Overall cavity depth | 688 |

| GAPS | |
|-----------------------------|----|
| | mm |
| G Minimum chassis clearance | 10 |
| Minimum visual gap | 15 |
| H Minimum chassis clearance | 10 |
| Minimum visual gap | 15 |

The models shown in this Planning Guide may not be available in all markets and are subject to change at any time. For the latest version of this document, please visit our website at fisherpaykel.com. Product specifications may vary from those shown. The Planning Guide is not intended to be used as installation guidance for any product. Detailed installation instructions are available on our website.

Washing Machine

WH126OR5* White

Heat Pump Dryer

DH106OR5** White

Stacking Kit with Tray

ASKS60W5 White

*Left Hand Hinge
 **Right Hand Hinge (Dryer hinges can be reversed)

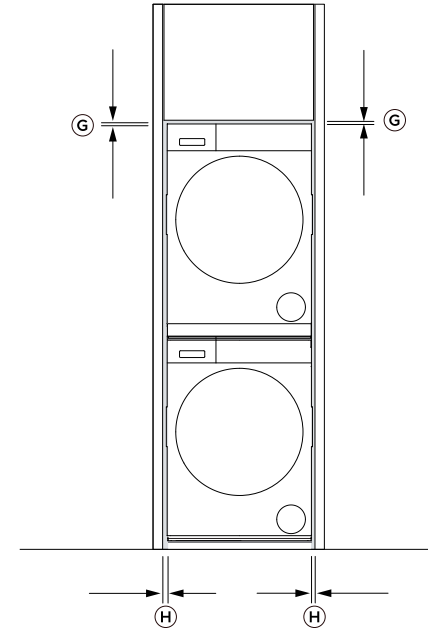
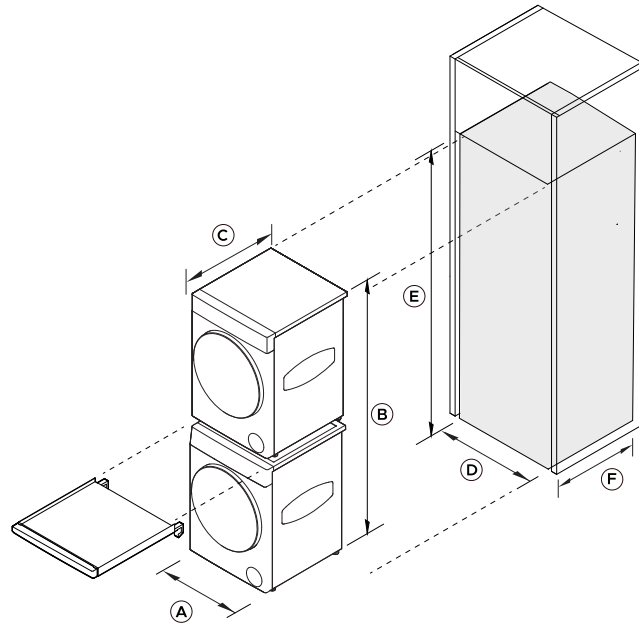

| PRODUCT DIMENSIONS | |
|---|------|
| | mm |
| A Overall products width Washer, Dryer, and Stacking Kit* | 595 |
| B Overall product height Washer, Dryer, and Stacking Kit | 1722 |
| C Overall product depth Washer, Dryer, and Stacking Kit | 682 |
| * Washer and Dryer width exclude the chassis form | |

| CAVITY DIMENSIONS | |
|-------------------------|------|
| | mm |
| D Overall cavity width | 624 |
| E Overall cavity height | 1734 |
| F Overall cavity depth | 688 |

| GAPS | |
|-----------------------------|----|
| | mm |
| G Minimum chassis clearance | 10 |
| Minimum visual gap | 15 |
| H Minimum chassis clearance | 10 |
| Minimum visual gap | 15 |

The models shown in this Planning Guide may not be available in all markets and are subject to change at any time. For the latest version of this document, please visit our website at fisherpaykel.com. Product specifications may vary from those shown. The Planning Guide is not intended to be used as installation guidance for any product. Detailed installation instructions are available on our website.

SERVICES

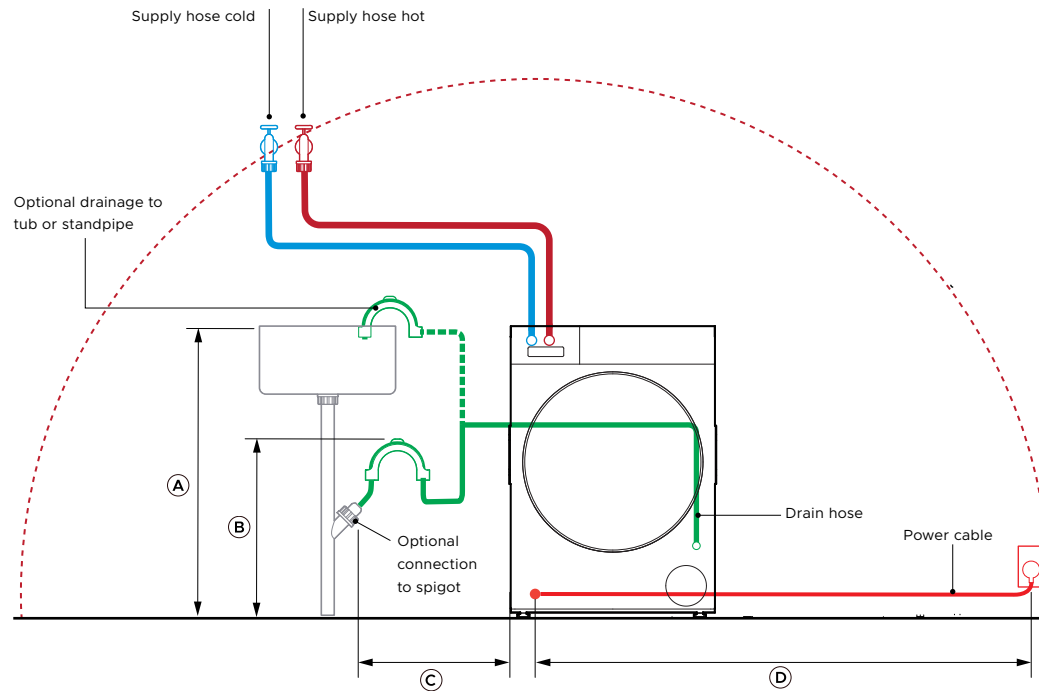

Model nos:

Front Loader Washing Machine - WH1260R5

Product Dimensions

| | mm |
|---|-------------|
| A Maximum standpipe or tub height | 1000 |
| B Minimum standpipe or tub height | 600 |
| C Maximum distance to standpipe when located on the left Maximum distance to standpipe when located on the right | 400 1000 |
| D Maximum power cord length to power outlet | 1400 |

Specifications

Electrical

| | |
|---------|----------------------------|
| Supply | 220 VAC, 50 Hz |
| Service | 10 Amps |
| Outlet | 3-pole plug with grounding |

Plumbing

| | |
|----------|--|
| Supply | Hose set provided |
| Pressure | Max. 1MPa Min. 30KPa; Min 6 litres/min |

NOTES: Connections may be located in an adjacent cabinet to either side of the washer.
Ensure power will remain accessible following install to allow access for any future product maintenance.
A washer and dryer without separate cold-water inlets shall be no more than 900mm apart in order to use steam cycles on the dryer.
Multiple product installation requires the design of water and power outlets according to local regulations.

----- INDICATES CABINETRY / PRODUCT DATUM

----- INDICATES CABINETRY CLEARANCES

----- INDICATES CUTOUT

IMPORTANT NOTE: Throughout this guide, dimensions may vary by +/- 2mm (1/16"). Please read the installation manual for detailed information on installing the product. For full installation instructions & specifications visit fisherpaykel.com

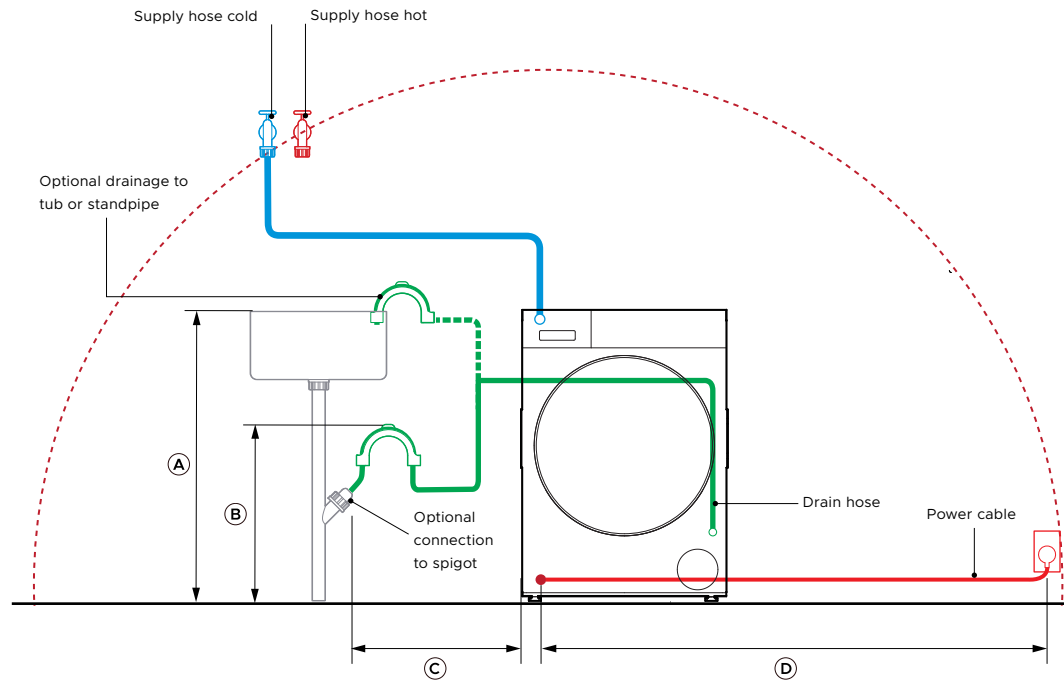

Model nos:

Front Loader Dryer - DH1060R5

Product Dimensions

| | mm |
|--|------|
| A Maximum standpipe or tub height | 1000 |
| B Minimum standpipe or tub height | 600 |
| C Maximum distance to standpipe when located on the left | 400 |
| Maximum distance to standpipe when located on the right | 1000 |
| D Maximum power cord length to power outlet | 1400 |

Specifications

Electrical

| | |
|---------|----------------------------|
| Supply | 220 VAC, 50 Hz |
| Service | 10 Amps |
| Outlet | 3-pole plug with grounding |

Plumbing

| | |
|----------|--|
| Supply | Hose set provided |
| Pressure | Max. 1MPa Min. 30KPa; Min 6 litres/min |

NOTES:

Connections may be located in an adjacent cabinet to either side of the washer. Ensure power will remain accessible following install to allow access for any future product maintenance.

A washer and dryer without separate cold-water inlets shall be no more than 900mm apart in order to use steam cycles on the dryer.

Multiple product installation requires the design of water and power outlets according to local regulations.

----- INDICATES CABINETRY / PRODUCT DATUM

----- INDICATES CABINETRY CLEARANCES

----- INDICATES CUTOUT

IMPORTANT NOTE: Throughout this guide, dimensions may vary by +/- 2mm (1/16"). Please read the installation manual for detailed information on installing the product. For full installation instructions & specifications visit fisherpaykel.com

DATA SHEET | SIDE BY SIDE WASHER AND HEAT PUMP DRYER

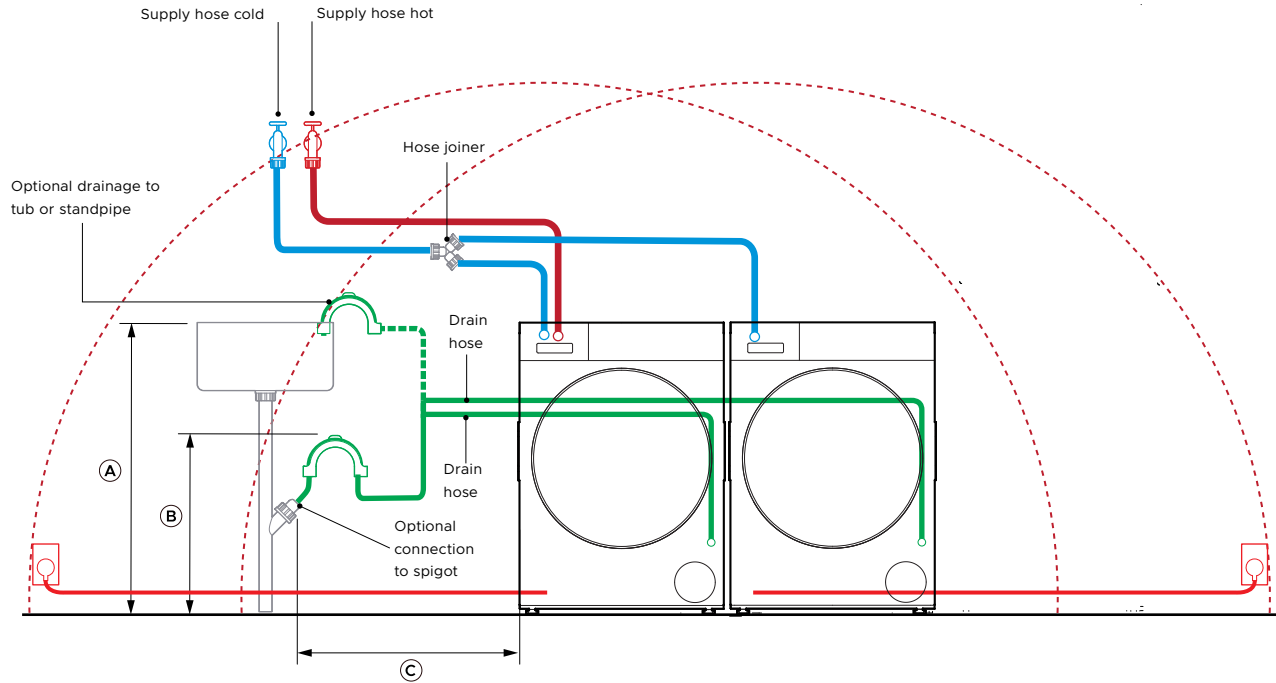

Model nos:

Front Loader Washing Machine - WH1260R5
Front Loader Dryer - DH1060R5

Product Dimensions

| | mm | |
|---|---|------|
| A | Maximum standpipe or tub height | 1000 |
| B | Minimum standpipe or tub height | 600 |
| C | Maximum distance to standpipe from washer and dryer | 400 |
| | Maximum distance to standpipe when located on the right | 1000 |

Specifications (per product)

Electrical

| | |
|---------|----------------------------|
| Supply | 220 VAC, 50 Hz |
| Service | 10 Amps |
| Outlet | 3-pole plug with grounding |

Plumbing

| | |
|----------|--|
| Supply | Hose set provided |
| Pressure | Max. 1MPa Min. 30KPa; Min 6 litres/min |

NOTES:

Connections may be located in an adjacent cabinet to either side of dryer

A washer and dryer without separate cold-water inlets shall be no more than 900mm apart.

Multiple product installation requires the design of water and power outlets according to local regulations.

----- INDICATES CABINETRY / PRODUCT DATUM

----- INDICATES CABINETRY CLEARANCES

----- INDICATES CUTOUT

IMPORTANT NOTE: Throughout this guide, dimensions may vary by +/- 2mm (1/16"). Please read the installation manual for detailed information on installing the product. For full installation instructions & specifications visit fisherpaykel.com

DATA SHEET | STACKED WASHER AND HEAT PUMP DRYER

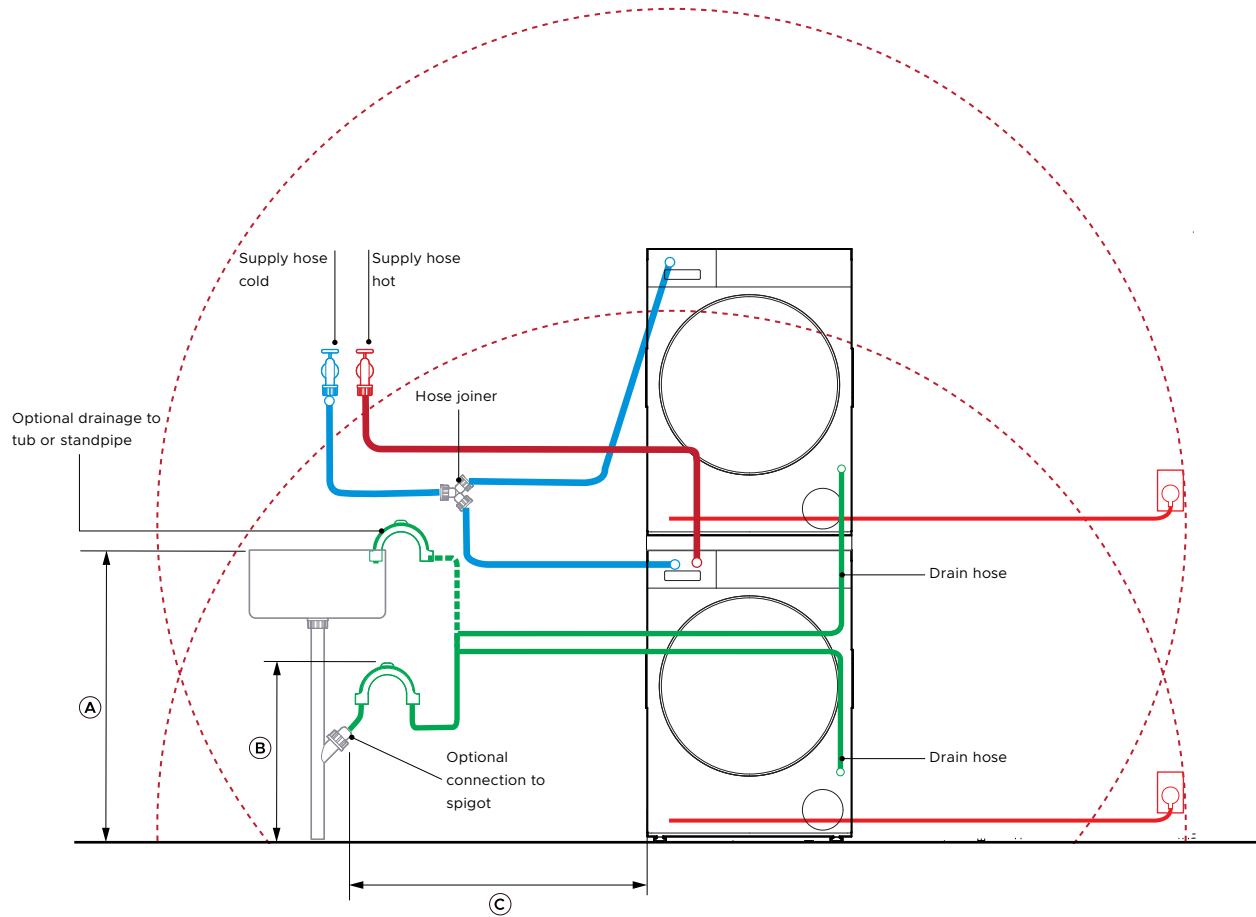

Model nos:

Front Loader Washing Machine - WH1260R5
 Front Loader Dryer - DH1060R5
 Stacking kit: ASKS60W5

Product Dimensions

| | mm |
|---|--|
| A | Maximum standpipe or tub height 1000 |
| B | Minimum standpipe or tub height 600 |
| C | Maximum distance to standpipe from washer and dryer 400 |
| | Maximum distance to standpipe when located on the right 1000 |

Specifications (per product)

Electrical

| | |
|---------|----------------------------|
| Supply | 220 VAC, 50 Hz |
| Service | 10 Amps |
| Outlet | 3-pole plug with grounding |

Plumbing

| | |
|----------|--|
| Supply | Hose set provided |
| Pressure | Max. 1MPa Min. 30KPa; Min 6 litres/min |

NOTES:

Connections may be located in an adjacent cabinet to either side of dryer

A washer and dryer without separate cold-water inlets shall be no more than 900mm apart.

Multiple product installation requires the design of water and power outlets according to local regulations.

----- INDICATES CABINETRY / PRODUCT DATUM

----- INDICATES CABINETRY CLEARANCES

----- INDICATES CUTOUT

IMPORTANT NOTE: Throughout this guide, dimensions may vary by +/- 2mm (1/16"). Please read the installation manual for detailed information on installing the product. For full installation instructions & specifications visit fisherpaykel.com

