

# **FISHER & PAYKEL**

## **INDUCTION COOKTOP**



CI302CTB1 , CI604CTB1, CI704CTB1,  
CI804CTB1, CI904CTB1 models

**INSTALLATION GUIDE**

**NZ AU GB IE HK SG**



## SAFETY AND WARNINGS

### ⚠ WARNING!



#### Electric Shock Hazard

Failure to follow this advice may result in electric shock or death.

- Disconnect the appliance from the mains electricity supply before carrying out any work or maintenance.
- Connection to a good earth wiring system is essential and mandatory.
- Alterations to the domestic wiring system must only be made by a qualified electrician.

### ⚠ WARNING!



#### Cut Hazard

Failure to use caution could result in injury.

- Take care: some edges are sharp.

### READ AND SAVE THIS GUIDE

#### General Use

- Read these instructions carefully before installing this product.
- Save these instructions for the local electrical inspector's use.
- Installation must comply with your local building and local electricity regulations.
- This appliance is to be installed and serviced only by Fisher & Paykel trained and supported service technician or qualified person.
- The manufacturer accepts no responsibility for the incorrect installation of appliances. Incorrect installation may result in personal injury, damage to property and may invalidate any warranty or liability claims.
- Do not modify this appliance.
- Do not use or store flammable materials on or near this appliance.
- Packing elements (eg plastic bags, polystyrene foam, staples, packing straps etc) and tools should not be left around during and after installation, especially if they are within easy reach of children, as these may cause serious injuries.
- Make sure you recycle the packaging material.
- Before disposing of any appliance, make sure that it can no longer be used and that all hazardous parts are removed or made harmless, so that children playing with the old appliance cannot harm themselves.
- Only genuine replacement parts may be used for servicing the appliance. These are available from your nearest Fisher & Paykel Service Center.
- This cooktop must be connected to the mains power supply only by a suitably qualified person.
- DO NOT use adapters, reducers, or branching devices when connecting the cooktop to the mains power supply to prevent overheating and fire.
- The power supply cable must not touch any hot parts and must be positioned so that its temperature will not exceed 75 °C at any point.

### WARNING!

**This cooktop requires adequate supply of cool air to fully function. The base of the cooktop must have direct unrestricted ventilation to the room where the cooktop is installed. There must be a 4mm air gap at the front of the cooktop (refer to section 'Venting clearances').**

### SAVE THESE INSTRUCTIONS

The models shown in this installation guide may not be available in all markets and are subject to change at any time. For current details about model and specification availability in your country, please go to our website [www.fisherpaykel.com](http://www.fisherpaykel.com) or contact your local Fisher & Paykel dealer.

## INITIAL CONSIDERATIONS

### BEFORE INSTALLATION

#### Before installation, please ensure the following:

- A suitable disconnection switch is incorporated in the permanent wiring, mounted and positioned to comply with the local wiring rules and regulations. A means of disconnection with at least a 3 mm air gap contact separation in all poles must be incorporated into the fixed wiring in accordance with the wiring rules, unless the local wiring rules allow for alternative means.
- The benchtop is made of a heat resistant material.
- The power supply cable is not accessible through cupboard doors or drawers.
- There is adequate flow of cool air from the cabinetry to the base of the cooktop. You may ventilate from adjacent cupboards, but ensure that the available air supply will not be restricted.
- The ventilation area must be at least two 50mm diameter holes or of an equivalent area.
- the isolating switch is easily accessible by the customer.
- You use heat-resistant and easy-to-clean finishes (such as ceramic tiles) for the wall surfaces surrounding the cooktop.
- The cooktop will not be installed directly above a dishwasher, fridge, freezer, washing machine or clothes dryer, as the humidity may damage the cooktop electronics.
- If the cooktop is installed above an oven, the oven has a built-in cooling fan.
- The installation will comply with all clearance requirements and applicable standards and regulations.
- You consult local building authorities and by-laws if in doubt regarding installation.

#### During installation, please ensure the following:

- Flush mounting or sealing this appliance into the bench with silicone or glue may make future servicing difficult. Fisher & Paykel will not be liable for any costs associated with removing or replacing a sealed-in appliance, nor for repairing any damage that may be incurred by doing this.
- Seal exposed bare edges of the cutout with an oil-based paint or moisture-proof polyurethane to prevent possible moisture creeping between the cooktop trim and the benchtop.
- Take extreme care not to chip, crack, or break the top glass surfaces during installation. A heavy metal tool or part accidentally dropped on the glass could damage it.
- If, after following the instructions given, correct performance cannot be achieved, please contact your nearest Fisher & Paykel Authorised Service Centre, Customer Care, or contact us through our local website listed at the end of this document.

### WARNING!

**The owner carries all risk for flush mounting the cooktop. The owner must ensure the cooktop has been cut out from the countertop before servicing can be carried out. Fisher & Paykel will not be liable for any costs associated with removing or replacing a flush-mounted and/or sealed-in product, nor for repairing any damage that may be incurred by doing this.**

### MULTIPLE PRODUCT INSTALLATION

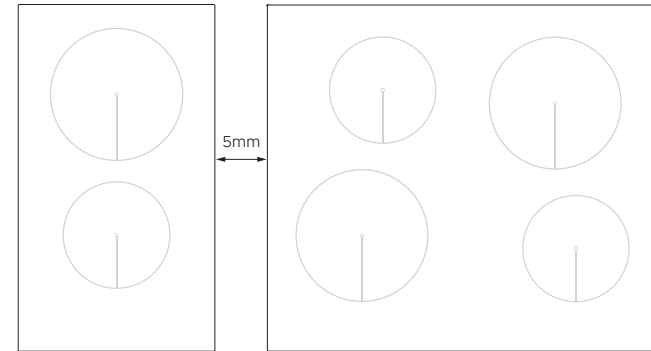

We recommend installing products in separate cutouts with a minimum distance of 5mm between the glass edges. If installing multiple products adjacent to each other within the same cutout, a separate under-bench joining strip kit is required for installation (part number 534731). The kit is available from the nearest Fisher & Paykel Authorised Service Centre or our website [www.fisherpaykel.com](http://www.fisherpaykel.com).

If installing different products adjacent to each other (eg a wok burner next to an induction cooktop), the minimum clearance measurements and cutout dimensions for the different products may vary. Always use the greater distance.

## SUPPLIED PARTS

- Keep all packing materials until the unit has been inspected.
- Inspect the product to ensure there is no shipping damage. If any damage is detected contact the dealer or retailer you bought the product from to report the damage.
- Fisher & Paykel is not responsible for shipping damage.

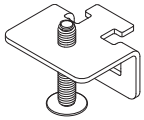

Clamping brackets  
(4) and screws (4)



Foam tape (1)

### CI302CTB only

Clamping brackets  
(2) and screws (2)

## TOOLS REQUIRED

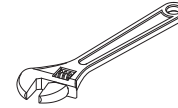

Wrench

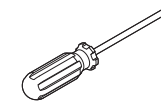

Crosshead  
screwdriver



Silicone

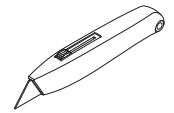

Cutter



Hex key

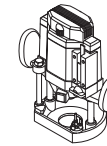

Router

## PRODUCT DIMENSIONS – 300MM MODELS

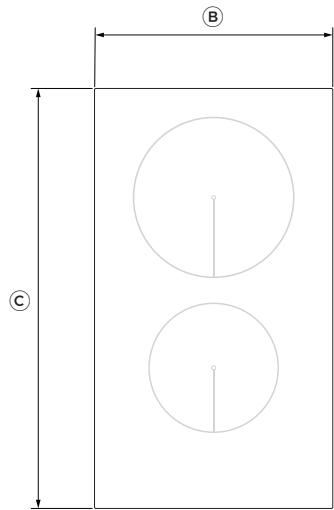

PLAN

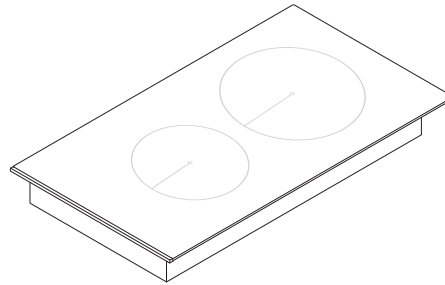

ISOMETRIC

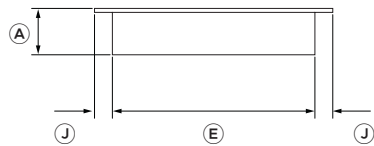

FRONT



PROFILE

PRODUCT DIMENSIONS	C1302CTB MM
Ⓐ Overall height of cooktop	59
Ⓑ Overall width of cooktop	300
Ⓒ Overall depth of cooktop	530
Ⓓ Height of chassis	54
Ⓔ Width of chassis	255
Ⓕ Depth of chassis	497
Ⓖ Height of cooktop surface	5
Ⓗ Depth of front overhang of cooktop surface	16
Ⓘ Depth of rear overhang of cooktop surface	16
Ⓙ Depth of side overhang of cooktop surface	23

Actual product dimension may vary by ± 2 mm

## PRODUCT DIMENSIONS — 600MM MODEL

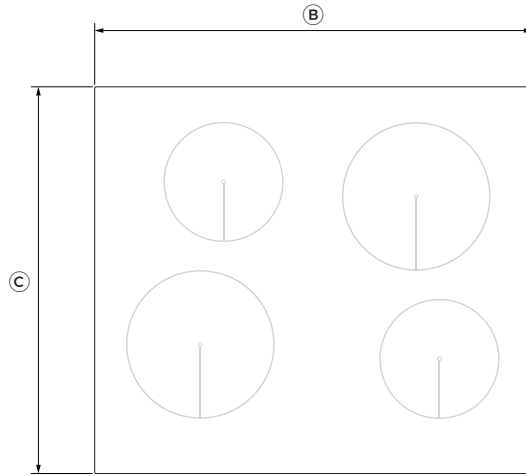

PLAN

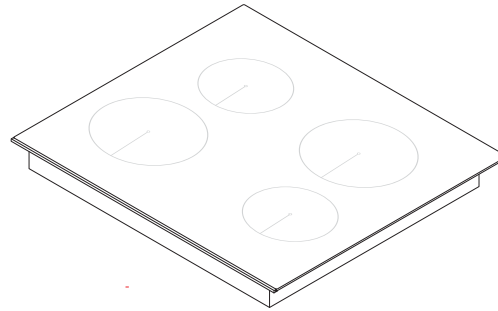

ISOMETRIC

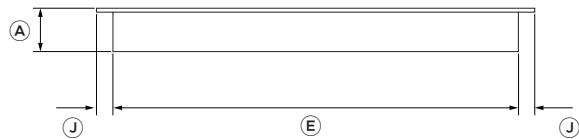

FRONT

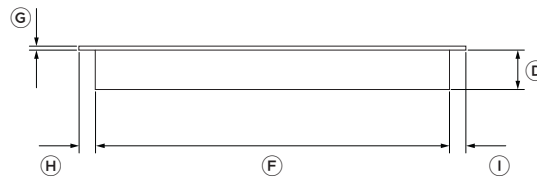

PROFILE

PRODUCT DIMENSIONS	C1604CTB
	MM
Ⓐ Overall height of cooktop	61
Ⓑ Overall width of cooktop	600
Ⓒ Overall depth of cooktop	530
Ⓓ Height of chassis	56
Ⓔ Width of chassis	555
Ⓕ Depth of chassis	485
Ⓖ Height of cooktop surface	5
Ⓗ Depth of front overhang of cooktop surface	23
Ⓘ Depth of rear overhang of cooktop surface	23
Ⓙ Depth of side overhang of cooktop surface	23

Actual product dimension may vary by ± 2 mm.

## PRODUCT DIMENSIONS – 700MM MODEL

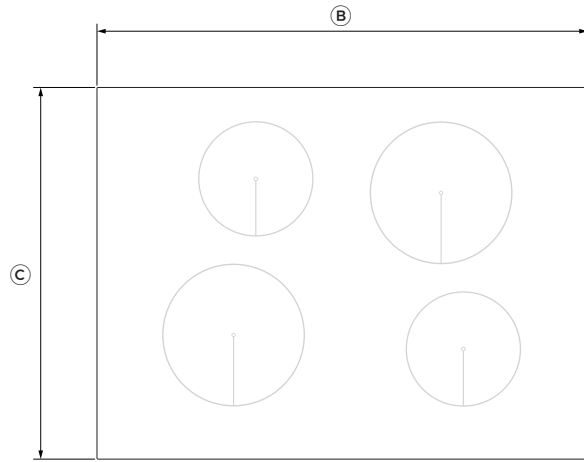

PLAN

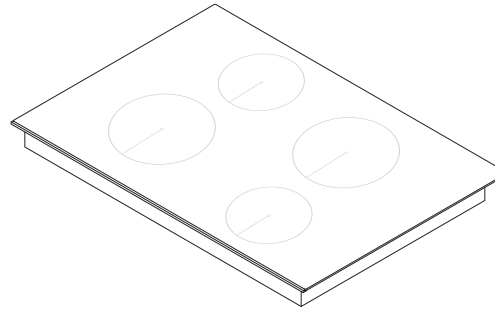

ISOMETRIC

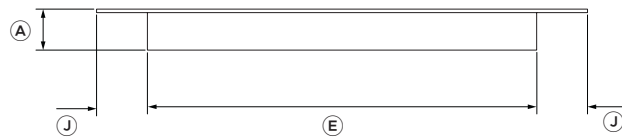

FRONT

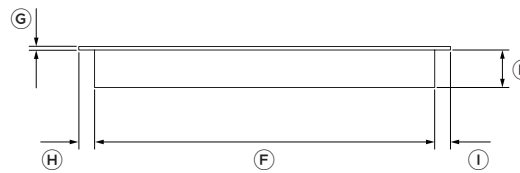

PROFILE

PRODUCT DIMENSIONS	C1704CTB
	MM
Ⓐ Overall height of cooktop	61
Ⓑ Overall width of cooktop	700
Ⓒ Overall depth of cooktop	530
Ⓓ Height of chassis	56
Ⓔ Width of chassis	555
Ⓕ Depth of chassis	485
Ⓖ Height of cooktop surface	5
Ⓗ Depth of front overhang of cooktop surface	23
Ⓘ Depth of rear overhang of cooktop surface	23
Ⓙ Depth of side overhang of cooktop surface	73

Actual product dimension may vary by ± 2 mm

## PRODUCT DIMENSIONS — 800MM MODEL

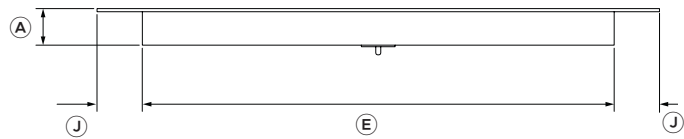
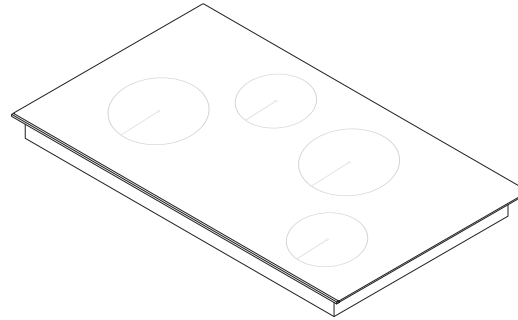
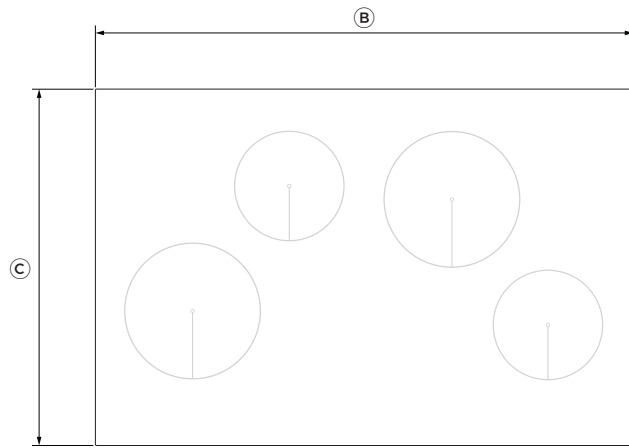

PRODUCT DIMENSIONS	C1804CTB
	MM
Ⓐ Overall height of cooktop	61
Ⓑ Overall width of cooktop	800
Ⓒ Overall depth of cooktop	530
Ⓓ Height of chassis	56
Ⓔ Width of chassis	754
Ⓕ Depth of chassis	485
Ⓖ Height of cooktop surface	5
Ⓗ Depth of front overhang of cooktop surface	23
Ⓘ Depth of rear overhang of cooktop surface	23
Ⓙ Depth of side overhang of cooktop surface	23

Actual product dimension may vary by ± 2 mm

## PRODUCT DIMENSIONS — 900MM MODEL

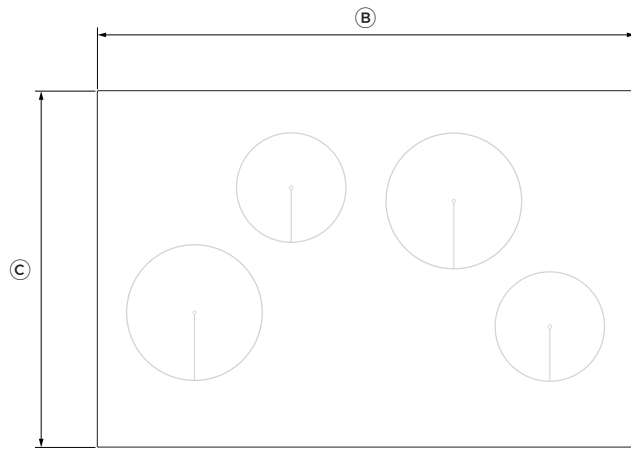

PLAN

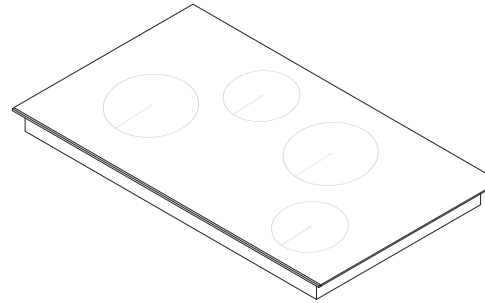

ISOMETRIC

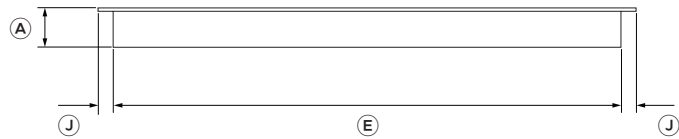

FRONT

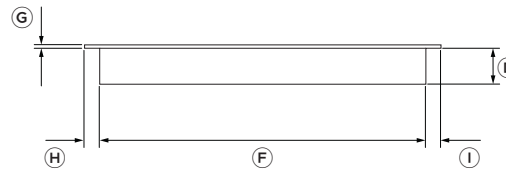

PROFILE

PRODUCT DIMENSIONS	C1904CTB
	MM
Ⓐ Overall height of cooktop	61
Ⓑ Overall width of cooktop	900
Ⓒ Overall depth of cooktop	530
Ⓓ Height of chassis	56
Ⓔ Width of chassis	755
Ⓕ Depth of chassis	485
Ⓖ Height of cooktop surface	5
Ⓗ Depth of front overhang of cooktop surface	23
Ⓘ Depth of rear overhang of cooktop surface	23
Ⓙ Depth of side overhang of cooktop surface	73

Actual product dimension may vary by ± 2 mm

## CUTOUT DIMENSIONS – 300MM MODEL

### PROUD INSTALLATION

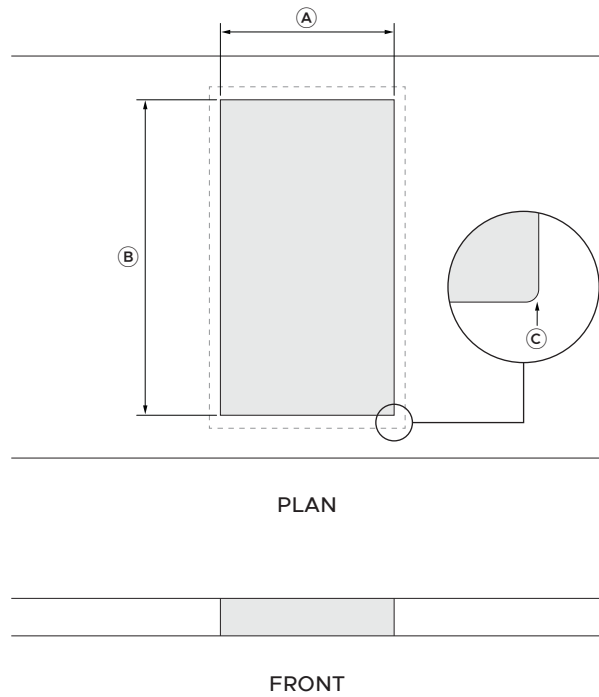

#### CUTOUT DIMENSIONS

**CI302CTB**

**MM**

Ⓐ Overall width of cutout	260
Ⓑ Overall depth of cutout	505
Ⓒ Corner radius of cutout	max 10

Cutout position is centred to the cooktop

### FLUSH INSTALLATION

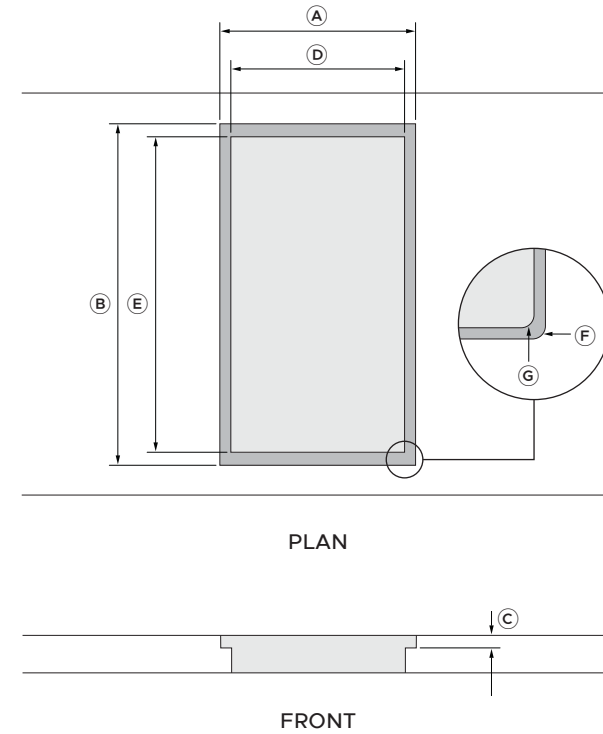

#### CUTOUT DIMENSIONS

**CI302CTB**

**MM**

Ⓐ Overall width of routed recess	305
Ⓑ Overall depth of routed recess	535
Ⓒ Height of routed recess	4
Ⓓ Width of cutout	260
Ⓔ Depth of cutout	505
Ⓕ Corner radius of routed recess	max 4
Ⓖ Corner radius of cutout	max 10

Cutout position is centred to the cooktop

## CUTOUT DIMENSIONS – 600MM MODEL

### PROUD INSTALLATION

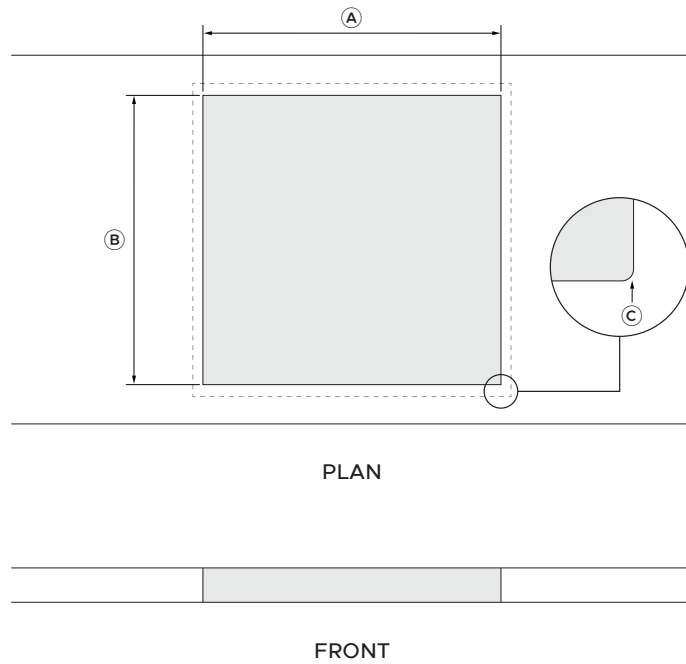

CUTOUT DIMENSIONS	C1604CTB
	MM
Ⓐ Overall width of cutout	560
Ⓑ Overall depth of cutout	490
Ⓒ Corner radius of cutout	max 10

Cutout position is centred to the cooktop

### FLUSH INSTALLATION

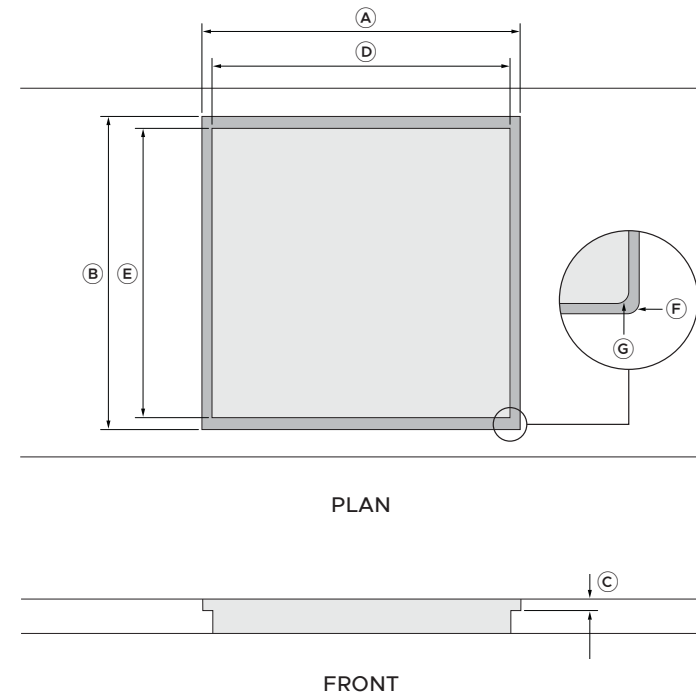

CUTOUT DIMENSIONS	C1604CTB
	MM
Ⓐ Overall width of routed recess	605
Ⓑ Overall depth of routed recess	535
Ⓒ Height of routed recess	4
Ⓓ Width of cutout	560
Ⓔ Depth of cutout	490
Ⓕ Corner radius of routed recess	max 4
Ⓖ Corner radius of cutout	max 10

Cutout position is centred to the cooktop

## CUTOUT DIMENSIONS – 700MM MODEL

### PROUD INSTALLATION

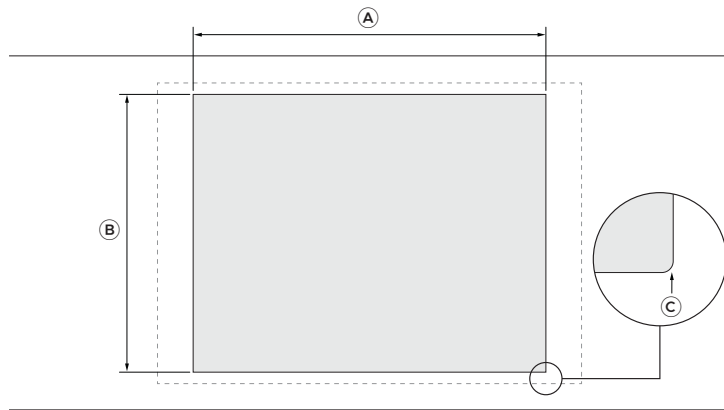

PLAN



FRONT

#### CUTOUT DIMENSIONS

**CI704CTB**

**MM**

Ⓐ Overall width of cutout	560
Ⓑ Overall depth of cutout	490
Ⓒ Corner radius of cutout	max 10

Cutout position is centred to the cooktop

### FLUSH INSTALLATION

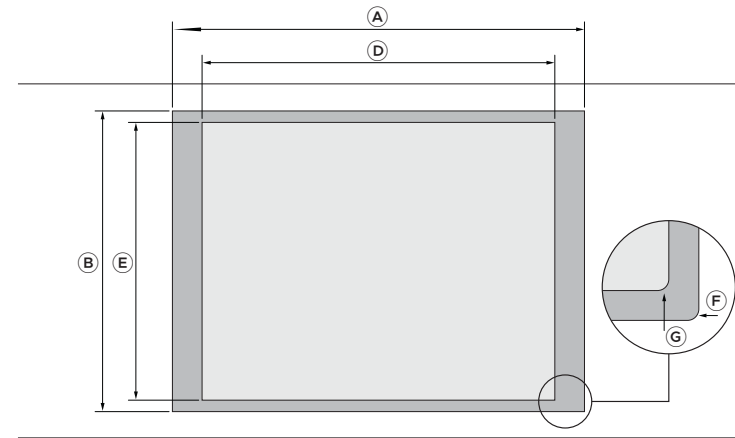

PLAN

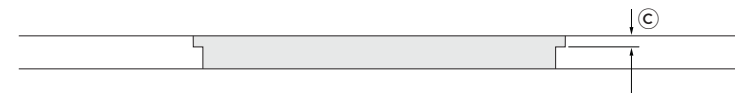

FRONT

#### CUTOUT DIMENSIONS

**CI704CTB**

**MM**

Ⓐ Overall width of routed recess	705
Ⓑ Overall depth of routed recess	535
Ⓒ Height of routed recess	4
Ⓓ Width of cutout	560
Ⓔ Depth of cutout	490
Ⓕ Corner radius of routed recess	max 4
Ⓖ Corner radius of cutout	max 10

Cutout position is centred to the cooktop

## CUTOUT DIMENSIONS – 800MM MODEL

### PROUD INSTALLATION



PLAN

FRONT

#### CUTOUT DIMENSIONS

**CI804CTB**

**MM**

Ⓐ	Overall width of cutout	760
Ⓑ	Overall depth of cutout	490
Ⓒ	Corner radius of cutout	max 10

Cutout position is centred to the cooktop

### FLUSH INSTALLATION

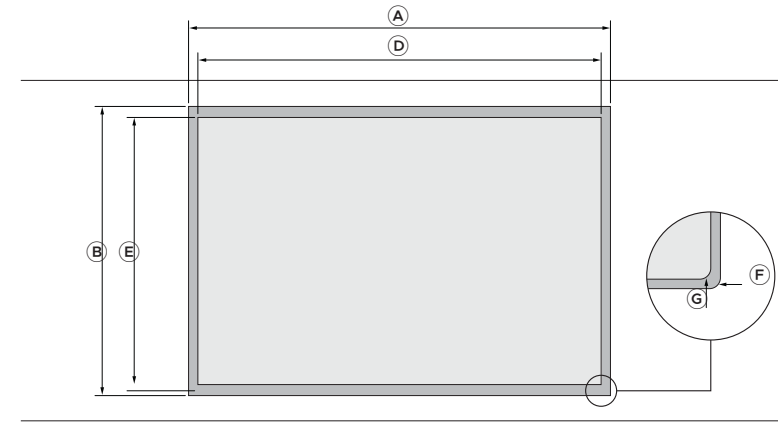

PLAN

FRONT

#### CUTOUT DIMENSIONS

**CI804CTB**

**MM**

Ⓐ	Overall width of routed recess	805
Ⓑ	Overall depth of routed recess	535
Ⓒ	Height of routed recess	4
Ⓓ	Width of cutout	760
Ⓔ	Depth of cutout	490
Ⓕ	Corner radius of routed recess	max 4
Ⓖ	Corner radius of cutout	max 10

Cutout position is centred to the cooktop

## CUTOUT DIMENSIONS – 900MM MODEL

### PROUD INSTALLATION

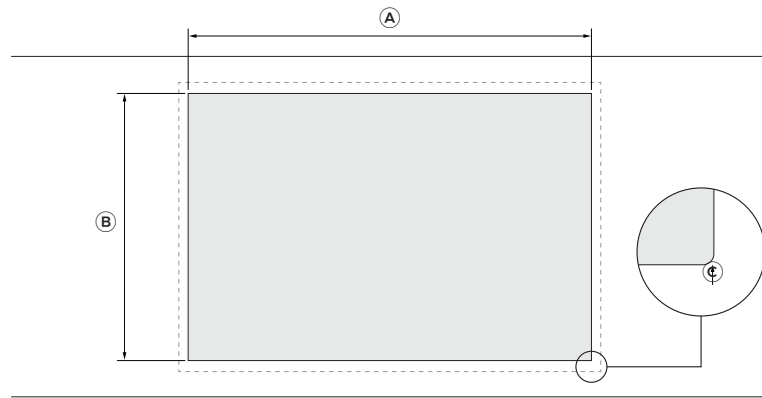

PLAN



FRONT

#### CUTOUT DIMENSIONS

**CI904CTB**

**MM**

Ⓐ	Overall width of cutout	760
Ⓑ	Overall depth of cutout	490
Ⓒ	Corner radius of cutout	max 10

Cutout position is centred to the cooktop

### FLUSH INSTALLATION

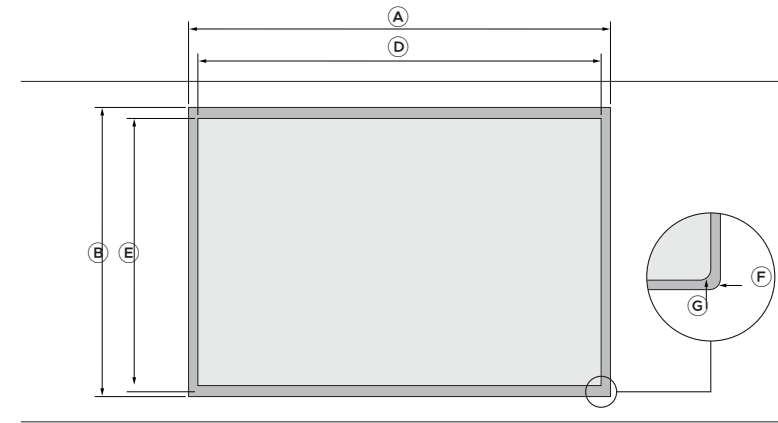

PLAN

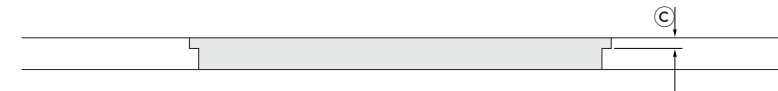

FRONT

#### CUTOUT DIMENSIONS

**CI904CTB**

**MM**

Ⓐ	Overall width of routed recess	905
Ⓑ	Overall depth of routed recess	535
Ⓒ	Height of routed recess	4
Ⓓ	Width of cutout	760
Ⓔ	Depth of cutout	490
Ⓕ	Corner radius of routed recess	max 4
Ⓖ	Corner radius of cutout	max 10

Cutout position is centred to the cooktop

## CLEARANCE DIMENSIONS – 300MM MODEL

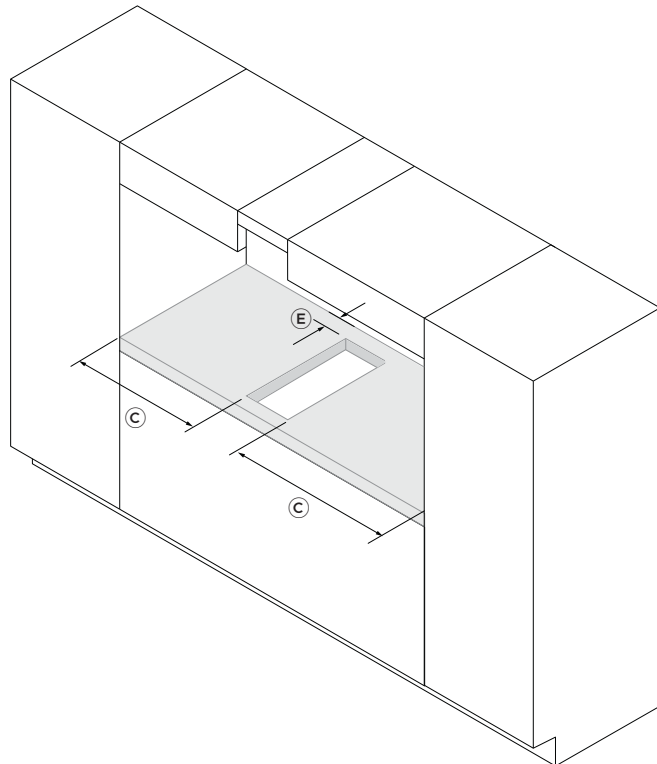
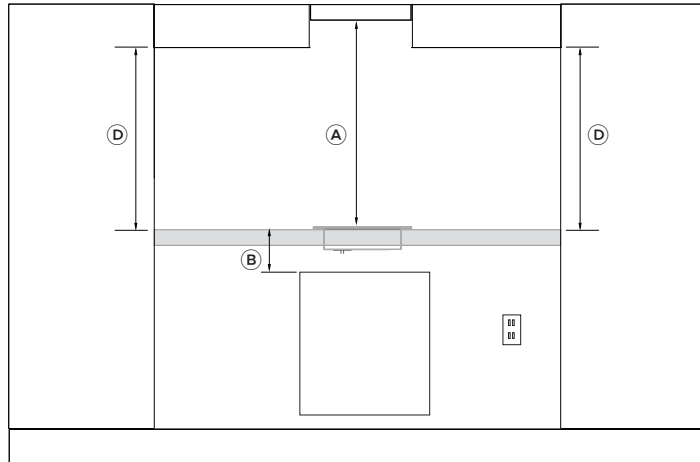

<b>CLEARANCE DIMENSIONS</b>		<b>CI302CTB</b>
		<b>MM</b>
Ⓐ	Minimum clearance from glass surface to rangehood	650
Ⓑ	Minimum clearance below top of countertop to top of any appliance*, companion product or obstruction below cooktop	77
Ⓒ	Minimum clearance from side edges of cutout to nearest combustable surface	30
Ⓓ	Minimum clearance from countertop to overhead cabinet (not directly above the cooktop)	450
Ⓔ	Minimum clearance from rear of cutout to nearest combustable surface	30
	Not illustrated: Minimum clearance from rear edge of cook surface to nearest combustable	23

\*The oven installed below the cooktop MUST have a cooling fan.

## CLEARANCE DIMENSIONS — 600MM MODEL

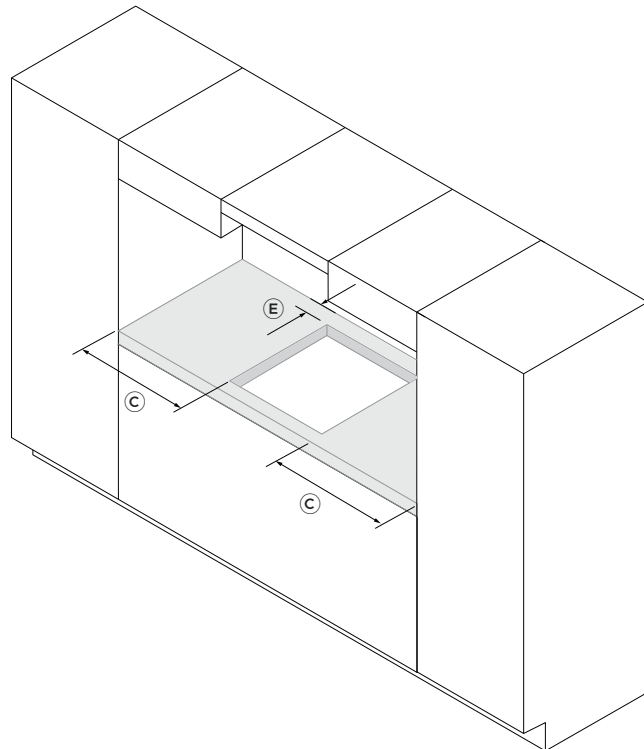
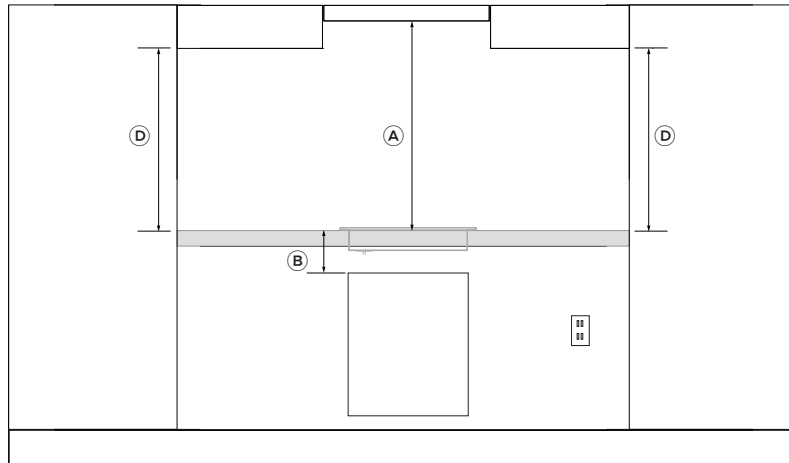

CLEARANCE DIMENSIONS		C1604CTB
		MM
Ⓐ	Minimum clearance from glass surface to rangehood	650
Ⓑ	Minimum clearance below top of countertop to top of any appliance*, companion product or obstruction below cooktop	77
Ⓒ	Minimum clearance from side edges of cutout to nearest combustable surface	30
Ⓓ	Minimum clearance from countertop to overhead cabinet (not directly above the cooktop)	450
Ⓔ	Minimum clearance from rear edge of cutout to nearest combustable surface	30
Not Illustrated: Minimum clearance from rear edge of cook surface to nearest combustable		10

\*The oven installed below the cooktop MUST have a cooling fan.

## CLEARANCE DIMENSIONS – 700MM MODEL

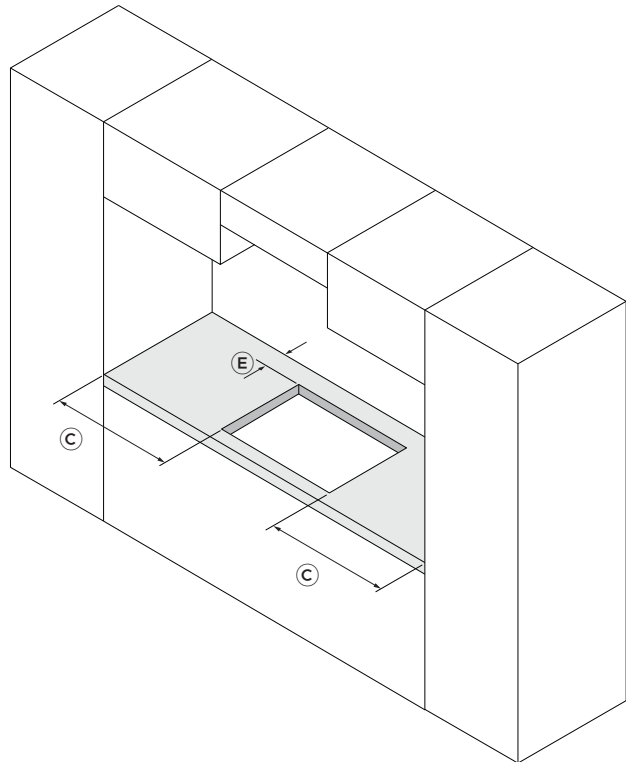
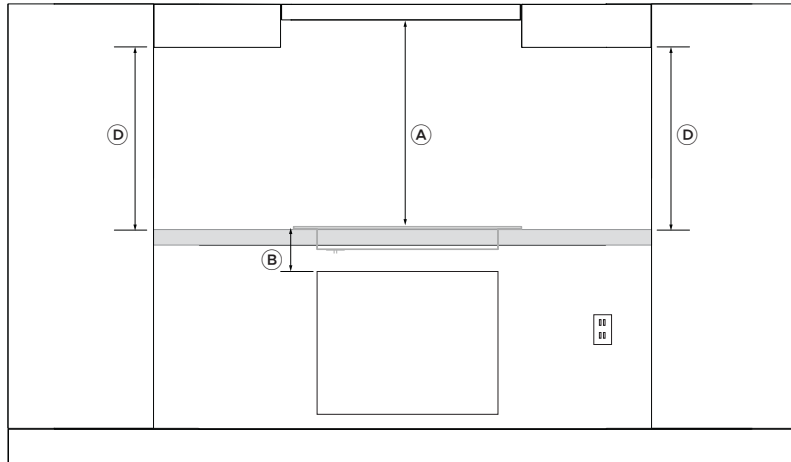

CLEARANCE DIMENSIONS	C1704CTB
	MM
Ⓐ Minimum clearance from glass surface to rangehood	650
Ⓑ Minimum clearance below top of countertop to top of any appliance*, companion product or obstruction below cooktop	77
Ⓒ Minimum clearance from side edges of cutout to nearest combustable surface	80
Ⓓ Minimum clearance from countertop to overhead cabinet (not directly above the cooktop)	450
Ⓔ Minimum clearance from rear edge of cutout to nearest combustable surface	30
Not Illustrated: Minimum clearance from rear edge of cook surface to nearest combustable	10

\*The oven installed below the cooktop MUST have a cooling fan.

## CLEARANCE DIMENSIONS — 800MM MODEL

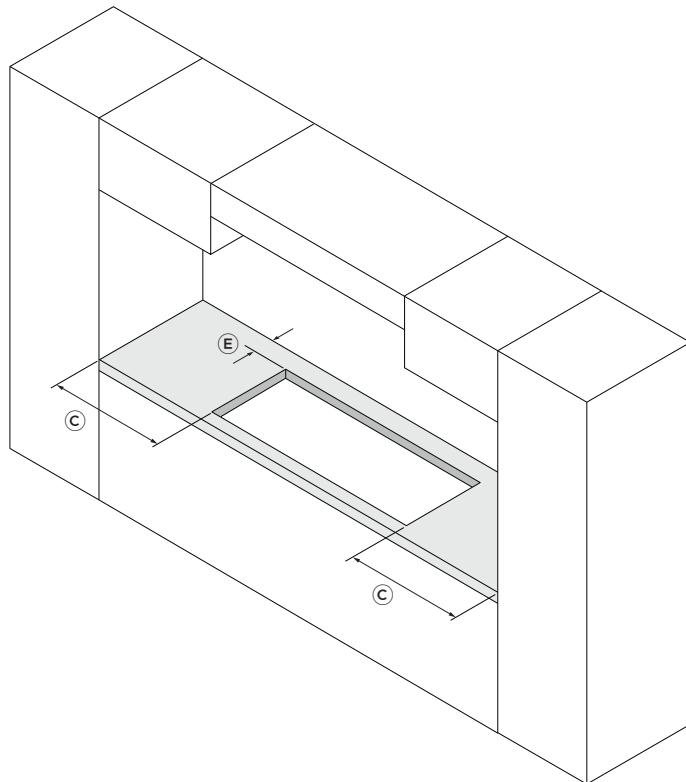
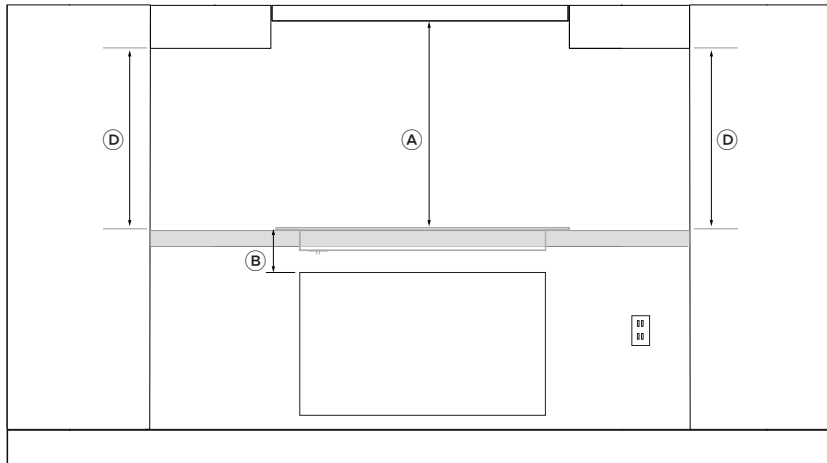

CLEARANCE DIMENSIONS	C1804CTB
	MM
Ⓐ Minimum clearance from glass surface to rangehood	650
Ⓑ Minimum clearance below top of countertop to top of any appliance*, companion product or obstruction below cooktop	77
Ⓒ Minimum clearance from side edges of cutout to nearest combustable surface	30
Ⓓ Minimum clearance from countertop to overhead cabinet (not directly above the cooktop)	450
Ⓔ Minimum clearance from rear edge of cutout to nearest combustable surface	30
Not Illustrated: Minimum clearance from rear edge of cook surface to nearest combustable	10

\*The oven installed below the cooktop MUST have a cooling fan.

## CLEARANCE DIMENSIONS – 900MM MODEL

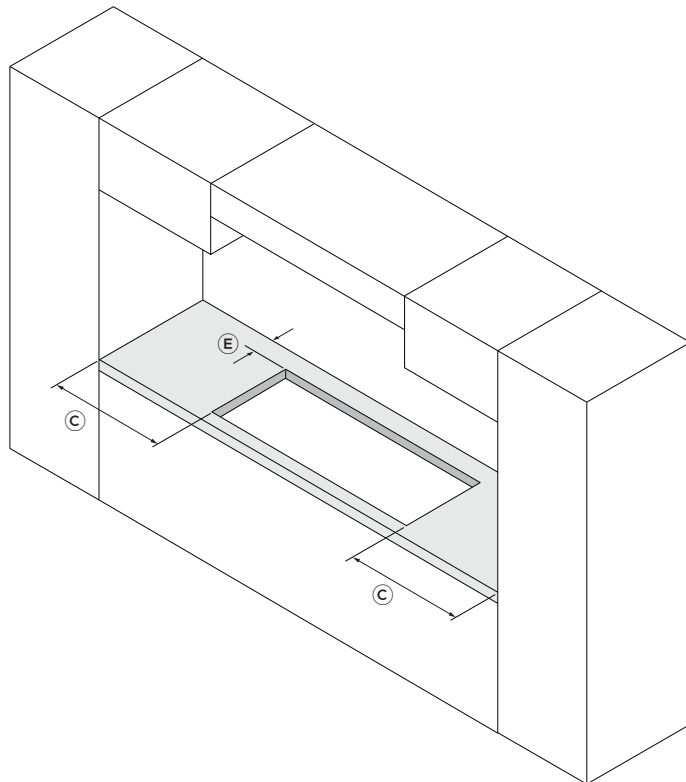
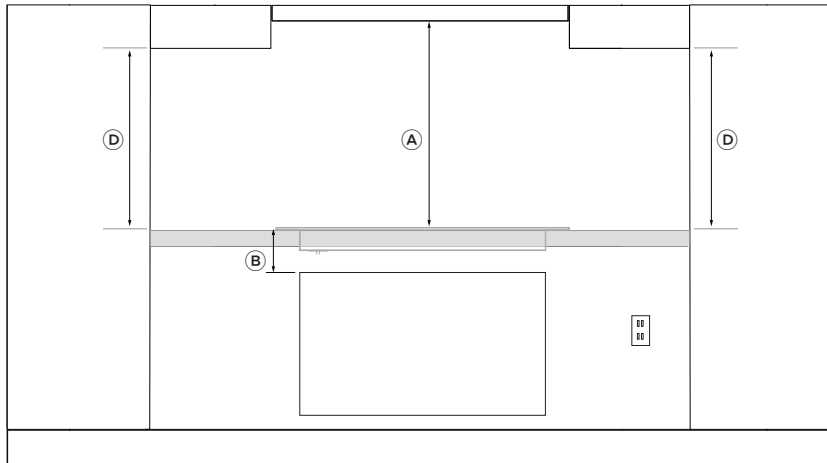

CLEARANCE DIMENSIONS	C1904CTB
	MM
Ⓐ Minimum clearance from glass surface to rangehood	650
Ⓑ Minimum clearance below top of countertop to top of any appliance*, companion product or obstruction below cooktop	77
Ⓒ Minimum clearance from side edges of cutout to nearest combustable surface	80
Ⓓ Minimum clearance from countertop to overhead cabinet (not directly above the cooktop)	450
Ⓔ Minimum clearance from rear edge of cutout to nearest combustable surface	30
Not Illustrated: Minimum clearance from rear edge of cook surface to nearest combustable	10

\*The oven installed below the cooktop MUST have a cooling fan.

## VENTING CLEARANCES

### DRAWER OR OTHER OBSTRUCTION

This cooktop requires adequate supply of cool air to fully function. The base of the cooktop must have direct unrestricted ventilation to the room where the cooktop is installed. There must be a 4mm air gap at the front of the cooktop.

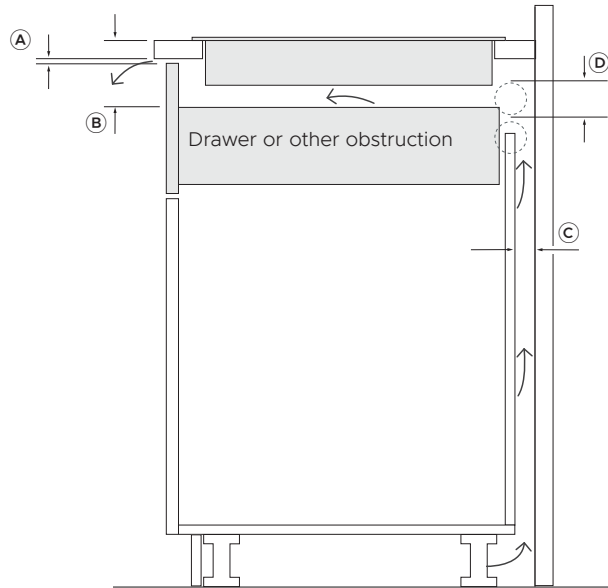

CLEARANCE DIMENSIONS	MM
Ⓐ Minimum ventilation gap at the front of the cooktop	4
Ⓑ Minimum clearance from cooktop to drawer or other obstruction	75
Ⓒ Minimum ventilation gap at the rear of the cooktop	20
Ⓓ Minimum diameter of cooling air hole	50

### OVEN WITH COOLING FAN

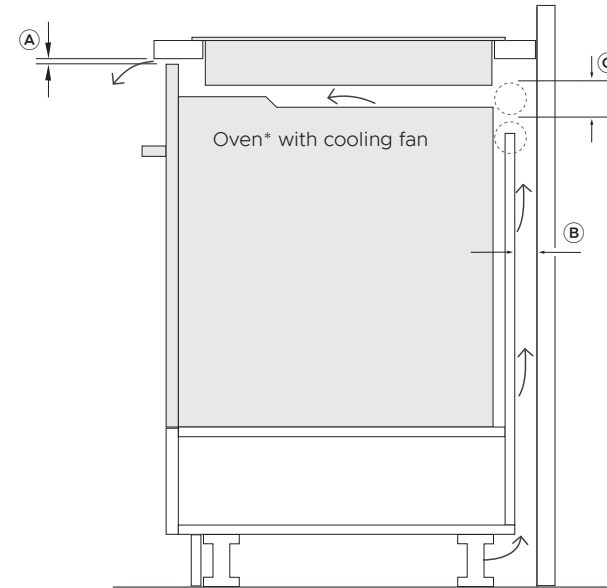

CLEARANCE DIMENSIONS	MM
Ⓐ Minimum ventilation gap at the front of the cooktop	4
Ⓑ Minimum ventilation gap at the rear of the cooktop	20
Ⓒ Minimum diameter of cooling air hole	50

\*Some ovens require installation in a sealed box. Please refer your oven installation guide for more information.

## PROUD INSTALLATION

1

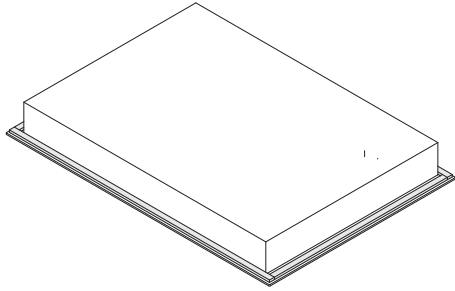

Turn the cooktop upside down on a protective cover.

2

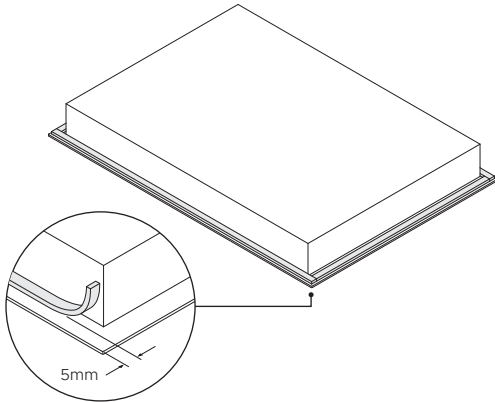

Apply adhesive foam seal around the glass overhang, 5mm from the edge of the glass.  
Ensure the adhesive side facing is down to form a continuous seal around the cooktop.

3

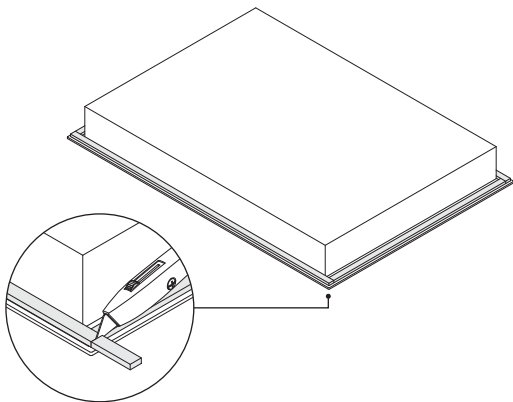

Trim the excess sealing material using a sharp cutter or trimmer knife.  
Take care not to damage the benchtop.

4

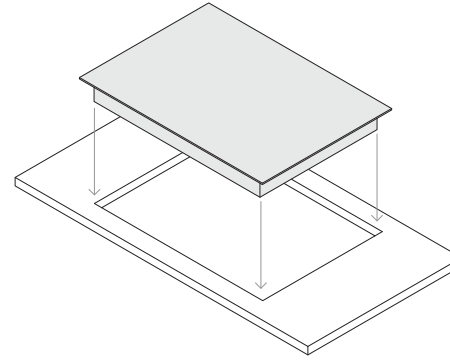

Gently lower the cooktop into the cutout ensuring you have access below the countertop to fit and secure the brackets.

5

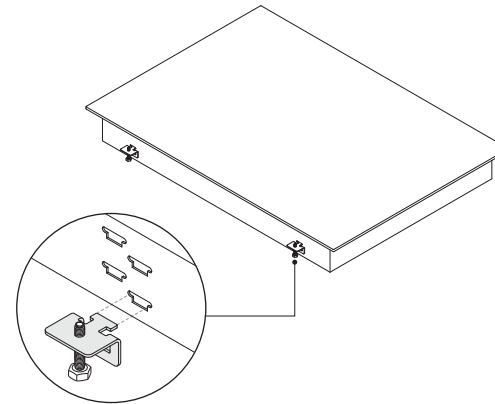

Locate the side brackets\* to the appropriate slots on the cooktop chassis. The correct slot height is determined by the thickness of your countertop.

6

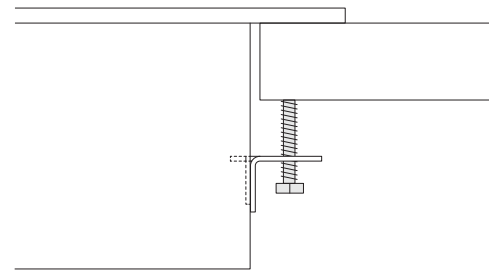

Tighten all screws to secure the cooktop to the countertop.  
Ensure cooktop is level.

\*The number of brackets varies based on your cooktop model.

## FLUSH INSTALLATION

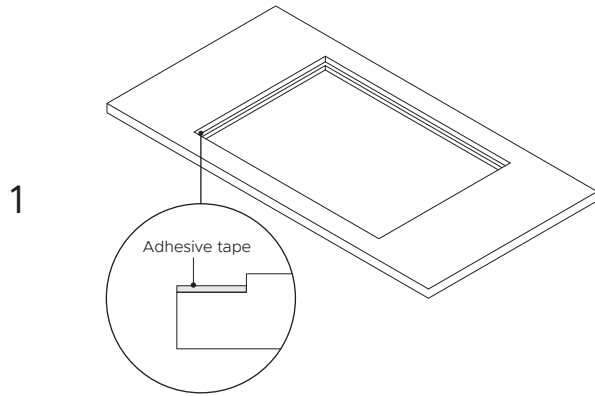

Prepare the countertop for flush installation. Use a router to cut out the edges of the countertop to specified depth (5mm).  
Attach an adhesive tape along the edges of the routed recess.

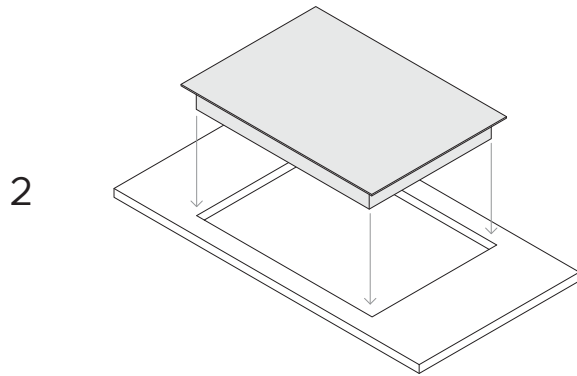

Gently lower the cooktop into the cutout ensuring you have access below the countertop to fit and secure the brackets.

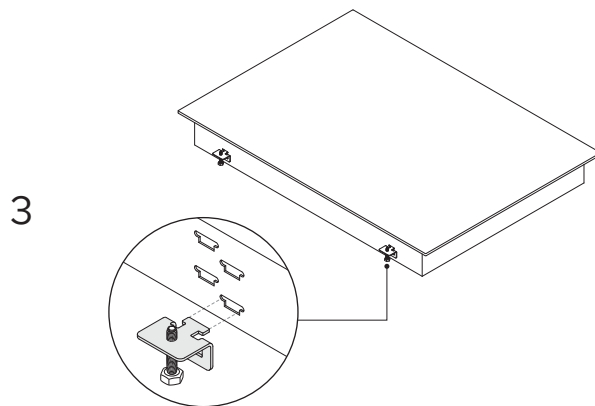

Locate the side brackets\* to the appropriate slots on the cooktop chassis. The correct slot height is determined by the thickness of your countertop.

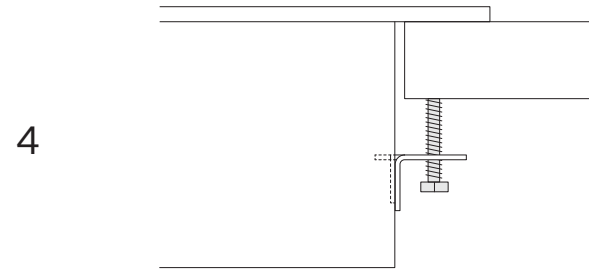

Tighten all screws to secure the cooktop to the countertop.  
Ensure cooktop is level.

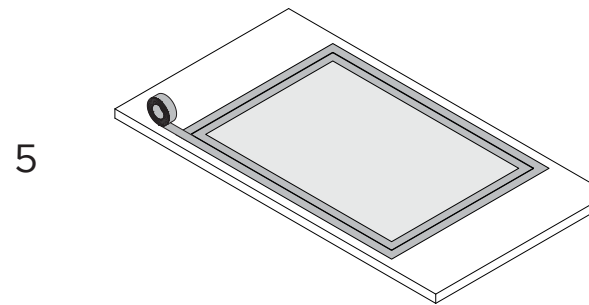

Mask off the area to be siliconed ensuring both the cooktop and countertop are protected.

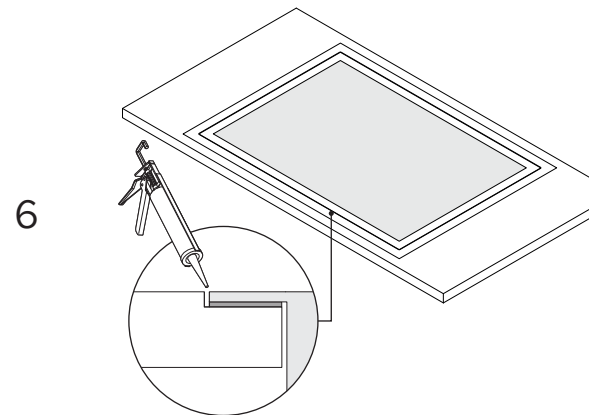

Apply silicone in the gap between benchtop and cooktop  
Wipe off excess silicone.

## ELECTRICAL CONNECTION

This cooktop must be connected to the mains power supply only by a suitably qualified person. To connect the cooktop to the mains power supply, do not use adapters, reducers, or branching devices, as they can cause overheating and fire. The power supply cable must not touch any hot parts and must be positioned so that its temperature will not exceed 75°C at any point. Check with an electrician whether the domestic wiring system is suitable without alterations. Any alterations must only be made by a qualified electrician.

Before connecting the cooktop to the mains power supply check that:

- The domestic wiring system is suitable for the power drawn by the cooktop.
- The voltage corresponds to the value given in the rating plate.
- The power supply cable sections can withstand the load specified on the rating plate.

MODEL	MAX. CURRENT DRAW	MAX. LOAD	VOLTAGE
CI302CTB*	16A	3700W	220-240V 1N ~
CI604CTB	32A	7400W	220-240V 1N ~
CI704CTB	32A	7400W	220-240V 1N ~
CI804CTB	32A	7400W	220-240V 1N ~
CI904CTB	32A	7400W	220-240V 1N ~

\*The CI302CTB is supplied with a cable. This must be wired into a suitably rated plug, permanent connection outlet or power isolator.

### ..... SINGLE-PHASE CONNECTION (220-240 V~) .....

Single-phase connection (220-240 V~)

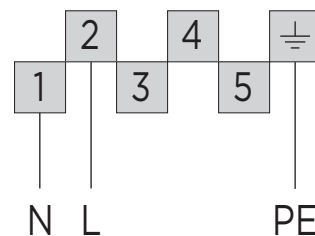

Ensure cable is tightened with screw. You may have to remove the screw first before fitting the clamp.

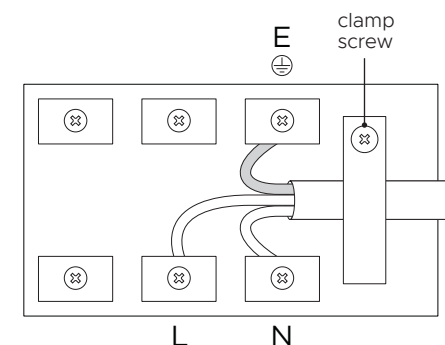

## INSTALLER CHECKLIST

Read all installation guidance in this document to see if the unit has been correctly installed. Ensure that installation has been completed correctly before use.

### TO BE COMPLETED BY THE INSTALLER

Ensure that:

- Is the cooktop earthed?
- Check that there is an adequate and constant flow of cool air from the cabinetry to the base of the cooktop.
- Check that the power supply cable is not accessible via cupboard doors or drawers and that it is NOT touching the cooktop.
- Is the cooktop clamped down securely?
- Check that the pan detection feature is working correctly. Turn on each cooking zone without putting any cookware on them. Are all the displays flashing?
- Check that all the cooking zones function correctly. Place suitable pans with water in them on each zone, then turn all of them on to a high setting. Is the water heating?
- Are all touch controls and displays functioning?
- To check that the 'hot surface' indicators function correctly, turn off all the zones.
- Is H displayed in all the cooking zone displays?
- Have you demonstrated the basic operation to the customer?

Explain the following to the customer:

- ① The importance of taking note of the safety warnings at the beginning of the user guide, especially for persons with pacemakers or other electrical implants.
- ② The 'hot surface' indicators.
- ③ Using induction suitable cookware only.
- ④ The pan detection feature.

Complete and keep for safe reference:

Model \_\_\_\_\_

Serial No. \_\_\_\_\_

Purchase Date \_\_\_\_\_

Purchaser \_\_\_\_\_

Dealer Address \_\_\_\_\_

Installer's Name \_\_\_\_\_

Installer's Signature \_\_\_\_\_

Installation Company \_\_\_\_\_

Installation Date \_\_\_\_\_





FISHERPAYKEL.COM

© Fisher & Paykel Appliances 2026. All rights reserved.

The models shown in this guide may not be available in all markets  
and are subject to change at any time.

The product specifications in this guide apply to the specific products and  
models described at the date of issue. Under our policy of continuous product  
improvement, these specifications may change at any time.

For current details about model and specification availability in your country,  
please go to our website or contact your local Fisher & Paykel dealer.

**591060G 05.26**