

FISHER & PAYKEL

BUILT-IN OVEN

OB90S9MEPX4, OB90S9MEPB1

USER GUIDE

AA SG

CONTENTS

Safety and warnings	3
Introduction	7
Control panel	8
First use	9
Using Your Oven	10
Oven functions	11
Using the rotisserie	13
Using the timer	15
Automatic cooking	16
Cooking chart	18
User preference settings	19
Sabbath setting	21
Care and cleaning	23
Preparing to use the self clean function	34
Using the self clean function	35
Replace oven light bulb	37
Troubleshooting	38
Alert codes	41
Manufacturer's Warranty and Service guide	43
Customer care	44

Registration

To register your product visit our website: fisherpaykel.com/register

⚠ WARNING!



Electric Shock Hazard

Failure to follow this advice may result in electric shock or death.

- Turn the oven off at the wall before replacing the oven lamp.

⚠ WARNING!



Fire Hazard

Failure to follow this advice may result in serious burns or death.

- Carefully follow the instructions for starting a Self Clean cycle.
- Do not place combustible materials (eg wood, fabric, plastic) in the oven during a Self Clean cycle.
- Do not place aluminium foil, dishes, trays, water or ice on the oven floor during cooking, this will irreversibly damage the enamel. Lining the oven with aluminium foil may cause fire.
- Never use your appliance for warming or heating the room. Persons could be burned or injured or a fire could start.
- Flammable materials should not be stored in an oven or near its surface.
- Failure to follow this advice may result in overheating, burning, and injury.

SAFETY AND WARNINGS

Hot Surface Hazard

Failure to follow this advice could result in burns and scalds.



- To avoid burns and scalds, keep children away from this appliance.
- Surfaces of the appliance may become hot enough to cause burns. Examples include the oven vent, the surface near the oven vent, and the oven door.
- Do not touch heating elements or interior surfaces of the oven. Heating elements may be hot even though they are dark in colour.
- Use protection when handling hot surfaces such as oven shelves or dishes.
- Use care when opening the oven door. Let hot air or steam escape before removing or replacing food.
- During and after use, do not touch, or let clothing or other flammable materials contact heating elements or interior surfaces of the oven until they have had sufficient time to cool.
- Failure to follow this advice could result in burns and scalds.

⚠ WARNING!



Cut Hazard

Failure to use caution could result in injury.

- Take care: some edges are sharp.

SAFETY AND WARNINGS

READ AND SAVE THIS GUIDE

WARNING!

- Do not attempt to operate this oven with the door open. Keep the door closed to prevent harmful exposure to microwave energy.
- Do not place any object between the oven front face and the door, or allow food or cleaner residue to accumulate on sealing surfaces.
- Do not operate the oven if it is damaged. Ensure the oven door is closed properly and there is no damage to the:
 - Door (bent)
 - Hinges and latches (broken or loosened)
 - Door seals and sealing surfaces.
- Ensure the oven is adjusted or repaired only by a Fisher & Paykel trained and supported service technician.
- The door or door seals are damaged, do not operate the oven until it has been repaired by a Fisher & Paykel trained and supported service technician.
- Follow the basic precautions to reduce the risk of fire, electric shock, injury to persons or exposure to excessive microwave oven energy when using your appliance.
- Installation
- This appliance is intended to be used for normal personal, family or household use.
- This is a built-in oven intended to be installed in a cavity only.
- Ensure that all the packing materials are removed from the inside of the door.
- DO NOT use the oven outdoors.
- Check the oven for any damage, such as misaligned or bent door, damaged door seals and sealing surface, broken or loose door hinges and latches and dents inside the cavity or on the door. If there is any damage, do not operate the oven and contact a Fisher & Paykel trained and supported service technician.
- This microwave oven must be placed on a flat, stable surface to hold its weight and the heaviest food likely to be cooked in the oven.
- Do not place the oven where heat, moisture or high humidity are generated or near combustible materials.

SAFETY AND WARNINGS

Electrical

- Never unplug your appliance by pulling on the power cord. Always grip the plug firmly and pull straight out from the outlet.
- Do not plug in any other appliance at the same power point as your appliance or use extension cords or double adapters or ungrounded (two prong) adapters.
- If the power supply cord is damaged, it must only be replaced by a Fisher & Paykel trained and supported service technician.
- All electrical repairs must be carried out by a Fisher & Paykel trained and supported service technician or qualified electrician in order to avoid a hazard.
- Ensure that the appliance is switched off before replacing the lamp to avoid the possibility of electric shock.
- It is hazardous for anyone other than a Fisher & Paykel trained and supported service technician or qualified electrician to carry out any service or repair operation that involves the removal of a cover which gives protection against exposure to microwave energy.

Disposal/Recycling

- The packaging materials for this appliance are recyclable.
- Operation
- Do not use the cavity for storage purposes. Do not leave paper products, cooking utensils or food in the cavity when not in use.
- Watch cooking time. Cook for the shortest amount of time indicated and add more as needed.
- Do not operate your appliance by means of an external timer or separate remote control system.
- Always position the shelves in the desired location while the oven is cool (before preheating). If a shelf must be removed while the oven is hot, do not let the oven mitts or pot-holder contact hot heating elements in the oven or the base of the oven.

Food Safety

- Use only utensils that are suitable for use in ovens.
- Be fire wise. Switch off or unplug the appliance and keep the door closed if smoke is observed in order to stop any flames.
- Do not heat unopened food containers. They can build up pressure that may cause the container to burst and result in injury.
- Food severely overcooked can smoke or ignite.
- Cover food items while cooking. Covers prevent spattering and help food items to cook evenly.

Child Safety

- Keep the appliance and its cord out of reach of children aged less than 8 years.
- Ensure that children (aged 8 years and above) and persons with reduced physical, sensory or mental capabilities or lack of experience and knowledge can only use the appliance if they are supervised or have been given instruction on how to use the appliance safely and understand the hazards involved.
- Never allow children to play with the appliance.

INTRODUCTION

Congratulations on your new purchase. Your oven has a number of features to make cooking a great experience for you:

- Nine oven functions, including Rotisserie (optional and can be purchased separately as a kit)
- Intuitive electronic controls and displays
- Illuminated halos around the dials for visual feedback
- Preference settings — see 'User preference settings' and 'Sabbath setting'.

Before you start

- Make sure the installer has completed the 'Final checklist' in the Installation instructions.
- Read this guide, taking special note of the 'Safety and warnings' section.
- Remove all the packaging and check that you have all the accessories listed below.
- Make sure you follow the instructions under 'Setting the clock and first use' before using your oven for cooking or baking.

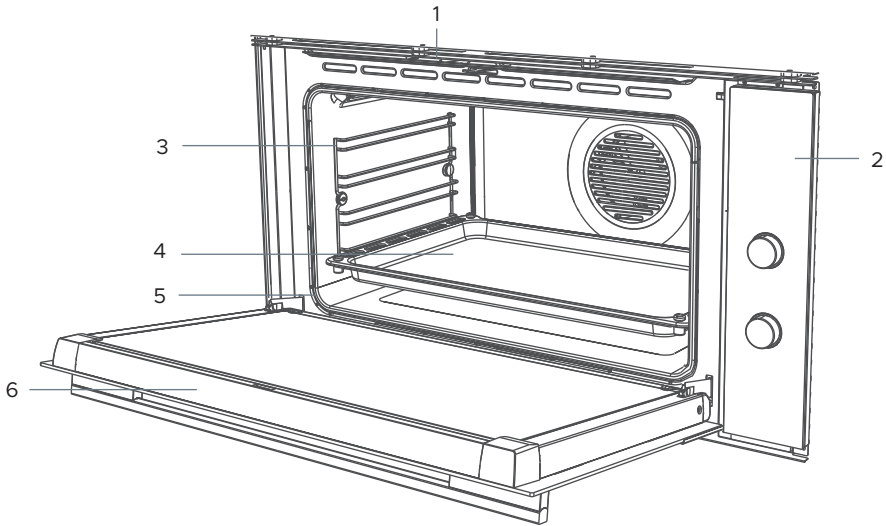

- 1 Oven vent louvres
- 2 Control panel
- 3 Side racks
- 4 Grill tray and rotisserie
- 5 Oven seal
- 6 Oven door and handle

Not illustrated:

- Baking tray
- Step-down oven shelf
- Oven shelf
- Grill rack

CONTROL PANEL

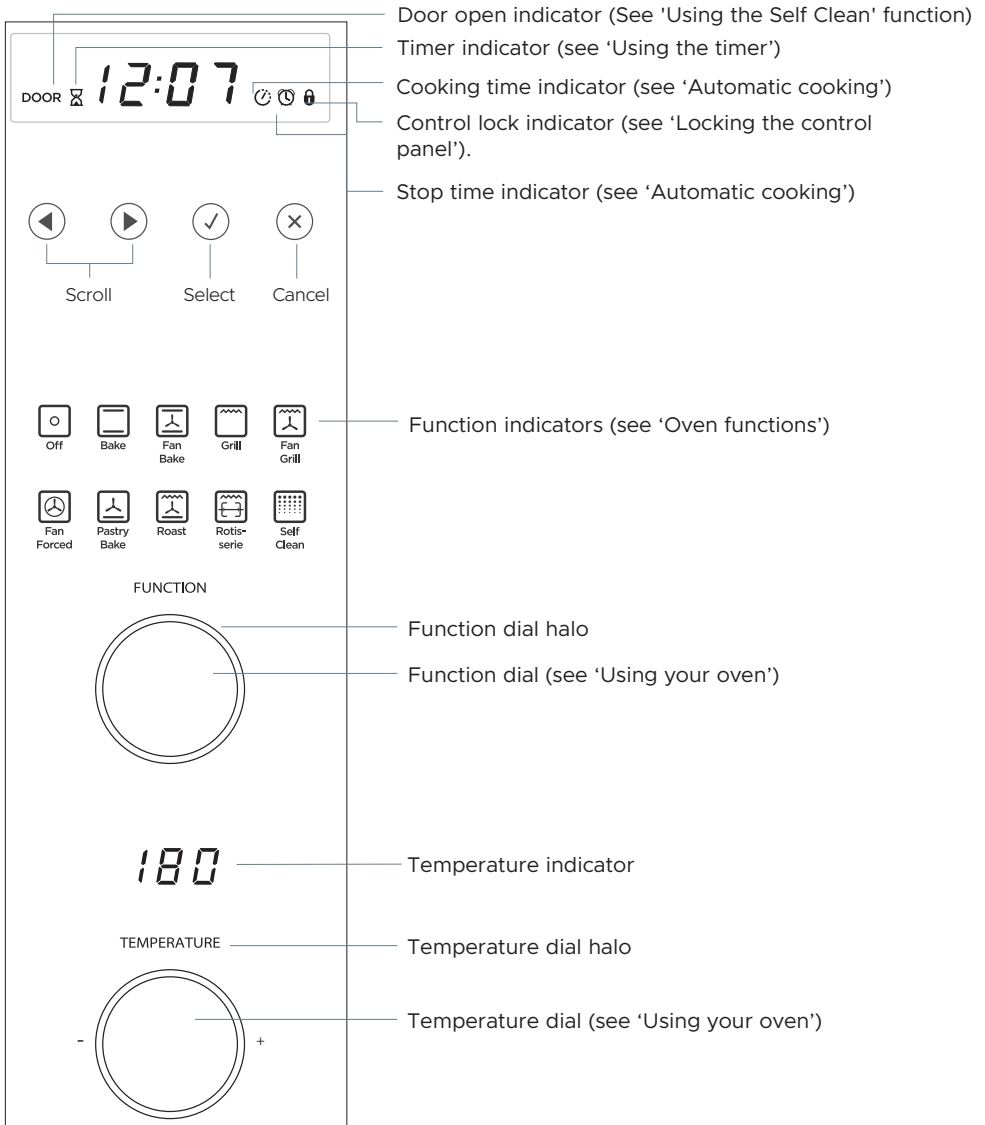

Locking the control panel

You can lock the control panel to prevent unintended use (e.g. children playing with the oven). Doing so will disable the dials and all the buttons.

To lock the control panel

1. Make sure the oven is not in use (the function dial is turned to Off) and neither automatic cooking nor the timer is set (no indicator is lit in the display).
2. Press and hold the select ✓ button until the lock indicator  comes on.

To unlock the control panel

3. Press and hold the cancel × button until the lock indicator  flashes and then goes out.

FIRST USE

Setting the clock

When your oven is first turned on, or after a power cut, the display will flash. You will need to set the clock in order to use the oven.

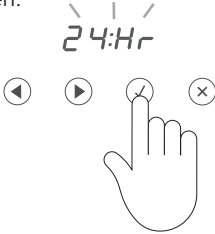

1. The display will flash 24 Hr.

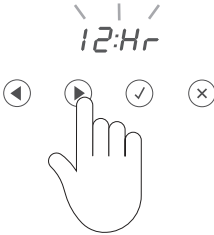

2. Press the left and right scroll ◀ ▶ buttons to set the time. Press the select ✓ button to confirm.



3. Press the right scroll ▶ button to scroll between 24 Hr and 12 Hr. Press the select ✓ button to confirm.

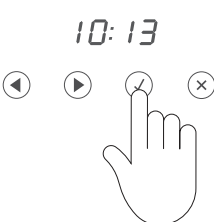

4. Press the select ✓ button to confirm. The time set will now be steadily lit.

Changing the time

Set the clock within the user preference menu.

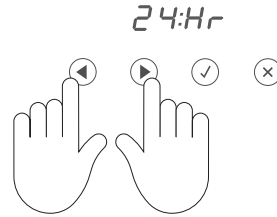

1. To enter the user preference menu, press and hold the left and right scroll ◀ ▶ buttons together for 3 seconds.

The display will either flash 12 Hr or 24 Hr.

Press the select ✓ button to confirm. The display will flash.

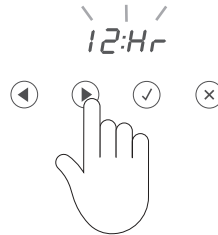

2. Press the right scroll ▶ button to scroll between 24 Hr, 12 Hr or OFF to turn the display off (see 'Setting User preferences' for more information).

Press the select ✓ button to confirm.

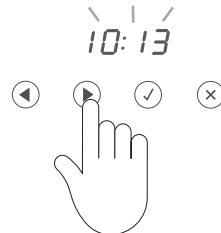

3. Press the left and right scroll ◀ ▶ buttons to set the time.

Press the select ✓ button to confirm.

USING YOUR OVEN

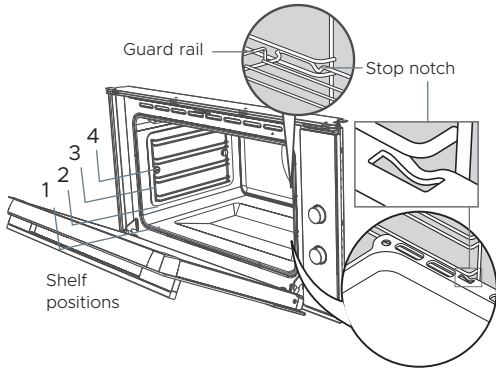

1. Insert the shelves that you need.

Ensure that,

- they are between two wires of a shelf position
- the stop notches point down
- the guard rail is at the back.

Note: The grill tray should be positioned between the two wires of a shelf position and orientated as shown.

2. Select a function. The halo will glow white.

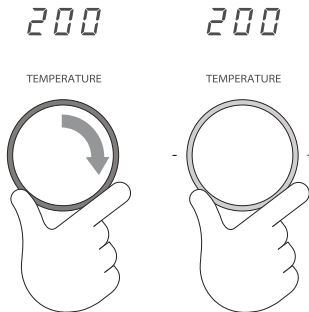

3. Set the temperature.

While the oven is heating up, the halo will glow red and the temperature indicator will alternately show the actual and set temperatures.

When the oven has reached set temperature, a long tone will sound and the halo will turn white.

Note: Grill provides instant radiant heat, so the halo will stay red and there will be no tone.

4. When you have finished cooking, turn the function dial to Off.

OVEN FUNCTIONS



Off

Selecting this will turn the oven off.



Bake

This is the traditional method of baking. It is best to bake on only one shelf at a time in this function. Ideal for large cakes and dishes that bake for several hours.



Fan Bake

Ideal for dishes like lasagne that need to brown on top and also single trays of small cakes or biscuits that bake in less than an hour.



Grill

Grill is the most suitable function for 'finishing off' many meals, for example browning the top of potato gratin and frittata. Use Grill to toast bread or to grill your favourite chicken, fish and steak. Note: heat levels are from LO (50% power) to HI (100% power), with settings from 1 to 9 in between. Grill provides instant radiant heat, so the temperature dial halo will stay red.



Fan Grill

Ideal for roasting tender cuts of meat and poultry. Use the lower shelf positions for larger items e.g. a whole chicken.

OVEN FUNCTIONS



Fan Forced

Great for multi-shelf cooking. The consistent temperature ensures baking is well risen. Cookies baked on Fan Forced are crisp on the outside and chewy in the middle.



Pastry Bake

Excellent for sweet and savoury pastry foods, for moist breads and brownies and cookies that you want extra chewy.



Roast

No pre-heating of the oven required. The meat is seared during an initial 20-minute grilling stage, then baked at the set temperature for the rest of the time, producing a tender, juicy, and flavourful roast. Great for roasting vegetables too.



Rotisserie (optional)

Rotisserie is a delicious way to cook meat and poultry. The slowly rotating food is basted continuously in its own juices, making it tender on the inside and well browned and full of flavour on the outside. See 'Using the rotisserie'.



Self Clean

The Self Clean cycle takes care of the mess and grime that is traditionally associated with oven cleaning. See 'Using the Self Clean function' for details. Note: this is NOT a cooking function.

USING THE ROTISSERIE

Optional rotisserie kits are available separately for purchase. Contact your dealer for availability.

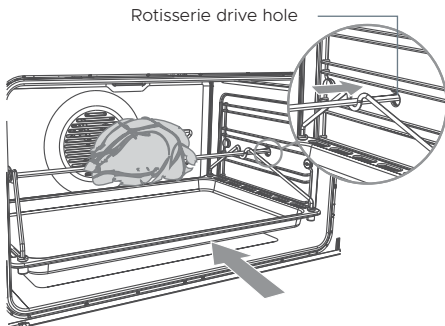
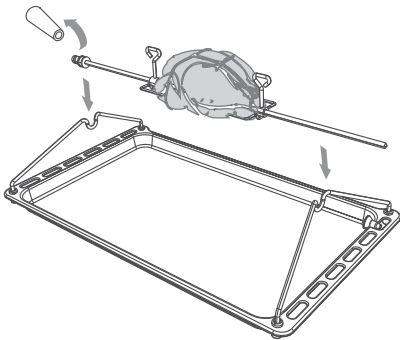
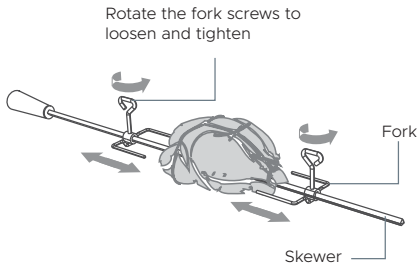
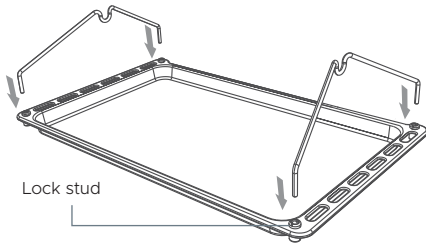

1. Prepare the rotisserie supports.

- Place the grill tray on the bench-top.
- Insert the supports into the lock studs making sure the supports face inwards.
- Push the supports all the way down to lock them in firmly

Secure the meat. Slide one fork onto the skewer first, followed by the meat and the second fork.

Important!

Take care, the forks are sharp!

2. When securing the meat, ensure that:

- the skewer goes through the centre of the meat
- the forks hold the meat firmly in place
- the fork screws are tightened
- there are no loose or projecting parts. Poultry should be trussed.

Note: the rotisserie can rotate up to 6 kg of meat.

3. Position the skewer on the supports.

- Place the skewer on the supports, and check that the meat does not touch the grill tray.
- Twist the handle off. It must not be left in the oven.

4. Place the rotisserie in the oven.

- Slide the grill tray all the way to the back on shelf position 1.
- Push the skewer through the hole cover on the right-hand wall of the oven, then insert it fully into the rotisserie drive hole.

USING THE ROTISSERIE

5. Select the Rotisserie function.

- The skewer will start rotating.
- Check that the meat does not touch the grill tray or the grill element at the top of the oven.



6. Set the temperature.

- We recommend around 210 °C.
- Note: The rotisserie will not rotate when the oven door is open.

2 10

TEMPERATURE



When you have finished using the rotisserie

1. Turn the oven off.
2. Using oven mitts, carefully disengage the right end of the skewer from the rotisserie drive hole.
3. Slide out the grill tray and place it on a heat-resistant surface.
4. Twist the handle onto the left end of the skewer.
5. Lift the skewer off the supports by the handle.
6. Loosen the fork screws and slide the meat off the skewer.

Tips for using the rotisserie

- For food safety reasons, we do not recommend using the rotisserie with stuffed meat.
- If your meat is too big or heavy (over 6 kg) for the skewer, place it on top of the grill rack in the grill tray, and use Fan Forced. This function will give a result similar to a rotisserie.
- Use a meat thermometer to ensure that meat is cooked through to a safe temperature.
- See 'Care and cleaning' for advice on cleaning the rotisserie parts.

USING THE TIMER

- You can use the timer at any time even if you are not using the oven.
- If the time is more than an hour, the display will count down in minutes (hr:min).
If it is less than an hour, it will count down in seconds (min:sec).
- You can set the timer for up to 23 hours 59 minutes.

Important!

The timer does NOT turn the oven off.

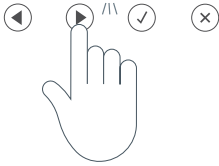

1. Select the timer by pressing the right scroll ► button once.

- The timer ⌚ indicator will appear and the colon will flash.



2. Press the select ✓ button to confirm.

- The display will flash to indicate the timer is ready to be set.

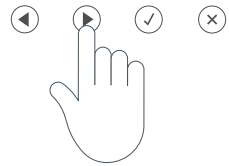

3. Set the time by pressing the scroll ◀ ► buttons.

- Holding the buttons down will speed up the scrolling.



Press the select ✓ button to confirm.

- The timer will then begin to count down.

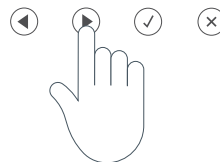

If you want to check the time of day, you can toggle between this and the timer countdown by pressing the scroll ◀ ► buttons.

To modify the timer setting

Ensure the display shows the remaining time counting down.

1. Press the select ✓ button.
2. Press the scroll ◀ ► buttons to set a new time.
3. Press the select ✓ button to confirm.

To cancel the timer setting

1. Ensure the display shows the remaining time counting down.

2. Press the cancel ✕ button until the display shows the time of day and the timer ⌚ indicator disappears.

When the set time is up

- The display will show 0:00 and a tone will sound every 15 seconds.
- Press any button to stop the tone sound. The display will revert to showing time of day.

AUTOMATIC COOKING

- You can set the oven to automatically turn on later, cook for a pre-set time (cooking time), then automatically turn off at a pre-set stop time. See the example and instructions below (steps 1 to 7).
- If you start cooking manually and only want the oven to turn off automatically after a set cooking time, simply set the cooking time following steps 1 to 3 below.
The oven will automatically turn off when the cooking time is over.

Important!

Remove your food from the oven as soon as possible after cooking or defrosting. This is to avoid contamination by organisms which may cause food poisoning. Take particular care during warmer weather.

Example: It is 11:05 am. You want your food to cook for 1 hour, and you would like it to be ready by lunchtime (12:30 pm).

Set the cooking time

11:05



1. Check the clock shows the correct time of day.

0:00



2. Press the right scroll ► button twice to scroll to the cooking time ⌘ indicator. Press the select ✓ button to confirm.

1:00



3. Press the right scroll ► button to set the cooking time. Ensure you allow for preheat time in your calculation. Press the select ✓ button to confirm.

Set the stop time

12:05



1. Press the right scroll ► button once to scroll to the stop time ⌘ indicator.
2. Press the select ✓ button to confirm.

12:30



3. Press the right scroll ► button to set the time you would like your food to be ready by (i.e. the stop time).
4. Press the select ✓ button to confirm..

AUTOMATIC COOKING

Select function and temperature



1. Select a function.

180

TEMPERATURE



2. Set the temperature.

When automatic cooking is set

- The oven and the lights will stay off, the halos will be unlit, but your oven is now set for automatic cooking. It will automatically turn on at the required time.
- In a few seconds, the display will show the time of day with the cooking time ⌚ and stop time ⌚ indicators lit.
- Note: you can modify the function and temperature while the oven is waiting to start cooking.

When the stop time is reached

The oven will automatically turn off and a long tone will sound.

To check the set cooking time and stop time

Use the scroll ◀ ▶ buttons.

To cancel automatic cooking

Turn the function dial to Off.

To change the cooking or stop time

Use the right scroll ▶ button to scroll to the cooking time ⌚ or the stop time ⌚, press to select the one you want to change and use the scroll ◀ ▶ buttons to change the time. Press the select ✓ button to confirm.

To see the current time of day

Press the cancel ✕ button.

COOKING CHART

Note:

- The settings in the following chart are guidelines only. Follow the instructions in your recipe or on food packaging and be prepared to adjust the oven settings and baking times to achieve the best possible results for you.
- Shelf positions are counted from the base up (1 is the lowest, 4 the highest).
- Arrange oven shelves before you turn the oven on, then preheat the oven to the required temperature. Place items in the oven only when the long tone has sounded and the temperature dial halo has turned from red to white.*
- Single shelf positions below use the flat oven shelf; where a multi shelf arrangement is recommended, the higher position uses the step-down shelf.
- Due to the width of the oven, a single shelf can usually accommodate double the standard recipe.

FOOD	ARRANGEMENT	SHELF POSITION(S)	BEST FUNCTION	TEMP (C)	TIME
Small cakes	single shelf	2	Bake	180-190	13-17 mins
	multi shelf	1 and 3	Fan Forced	160-170	16-23 mins
Scones	single shelf	2	Fan Forced	210-230	8-12 mins
	multi shelf	1 and 3	Fan Forced	210-230	8-16 mins
Sponge	2 small pans(20 cm), on single shelf	2	Bake	170-190	25-35 mins
	1 large pan (26 cm)	2	Bake	175	30-40 mins
Light fruit cake	2 pans (21 cm), on single shelf	2	Bake	155-165	1 hr 30 mins
Rich fruit cake	exact baking time will depend on size	2	Bake	130-150	3-6 hrs
Apple pie	single shelf	1	Bake	185	35-45 mins
Quiche	single shelf	1	Bake	180-200	30-40 mins
Meringues	single shelf	1	Bake	100-120	1 hr
Bread rolls	single shelf	1	Bake	210-230	15-20 mins
Muffins	2 x 12 muffin trays on single shelf	3	Fan Forced or Fan Bake	190-200	10-15 mins
Pastry case (baked 'blind')	1 flan tin (21 cm)	1 or 2	Pastry Bake	200	10 mins with beans, then 10 mins without
Roast Chicken	Rotisserie	1	Rotisserie	210	20-30 mins/ 450gms
Roast beef (boneless)	single shelf	1 or 2	Roast	160-170	35-40 mins/ 450gms
Lasagna	single shelf	2	Fan Bake	175-180	40-50 mins

* Note: the colour change and tone may occur some time after the set temperature has been reached. This is because—when heating up from cold—your oven is designed to initially heat to a temperature somewhat higher than what you have set. This is to provide optimal baking conditions right from the start.

USER PREFERENCE SETTINGS

You can set your oven to:

- display the temperature in degrees Celsius or Fahrenheit
- give audio feedback (tones and beeps) or operate quietly
- display time as 12-hr or 24-hr
- operate with the display off
- have its lights on or off during cooking

operate in Sabbath setting (see 'Sabbath setting' following).

Note: you cannot change user preference settings when the oven is set for automatic cooking.

How to change preference settings

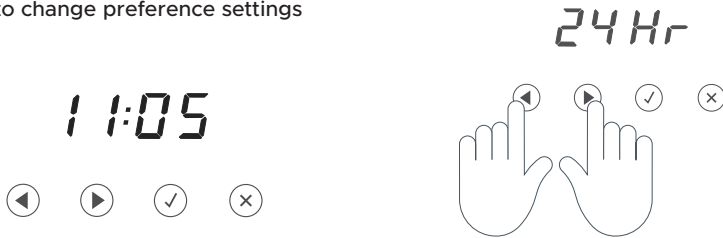

1. Check the display shows the time of day and the function dial is set to OFF.

If you're unsure, press the cancel **X** button twice.

2. Press and hold the scroll **◀ ▶** buttons together for 3 seconds to enter the user preference menu.

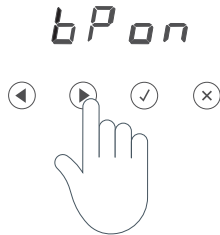

3. Press the right scroll **▶** button to scroll to the setting you want to change. Refer to the table following.

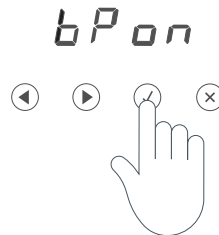

4. Press the select **✓** button to select the particular setting.

The display will flash.

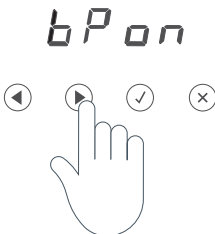

5. Press the right scroll **▶** button to scroll through the options for that particular setting. Refer to the table below.



6. Press the select **✓** button to save the new option.

For all options except 'Display off': press the cancel **X** button to quit the user preference menu.

USER PREFERENCE SETTINGS

SETTING	DEFAULT OPTION	ALTERNATIVE OPTION(S)	
TIME SCALE AND 'DISPLAY OFF' OPTION Select between 24-hr or 12-hr clock display or set 'Display off' option if you only need the basic functionalities of your oven	24 HR <i>24Hr</i>	12 HR <i>12Hr</i>	DISPLAY OFF** <i>oFF</i>
TEMPERATURE SCALE Select between degrees Celsius or Fahrenheit	CELSIUS <i>oC</i>	FAHRENHEIT <i>oF</i>	
AUDIO FEEDBACK Turn the beeps and tones on or off*	BEEPS/TONES ON <i>bPon</i>	BEEPS/TONES OFF <i>bPoF</i>	
OVEN LIGHTS Have the light off during cooking if you want to save power or want the food you cook to be a surprise for others!	LIGHTS ON DURING COOKING <i>Lton</i>	LIGHTS OFF DURING COOKING <i>LtoF</i>	
SABBATH SETTING	SABBATH OFF <i>SboF</i>	See 'Sabbath setting' for instructions.	

* The timer tone and alert beeps will sound even if you save the BEEPS/TONES OFF option.

** With this option saved, you can still use the oven and timer but the display will be unlit and the buttons will be unresponsive. To quit this option and enable the display, press and hold 'Cancel' X.

SABBATH SETTING

This setting is designed for religious faiths that observe a 'no work' requirement on the Sabbath.

While your oven is in Sabbath setting

- The display, dial halos and indicators will be unlit, the buttons will be unresponsive.
- No tones or beeps will sound.
- No alert codes or temperature changes will be displayed.
- The oven lights will stay on. If you want the oven lights to be off during Sabbath setting, first select the 'Lights off' option as described in 'User preference settings', and only then set Sabbath setting.
- Bake is the only function available in Sabbath setting.

How to set Sabbath setting



1. Select the Bake function.
Set the desired temperature.
Wait until the oven starts up.



3. Press the right scroll ► button to scroll to the Sabbath setting.
Press the select ✓ button to select the Sabbath setting. The default option is 'Sabbath off'.

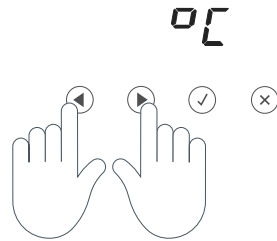

2. Press and hold the scroll ◀ ▶ buttons together for 3 seconds to enter the user preference menu.

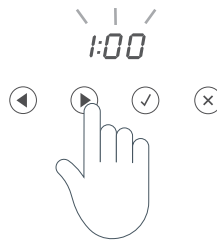

4. Press the select ✓ button to activate the option.
 - The display will flash 1:00 .

SABBATH SETTING

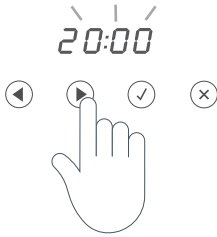

5. Press the scroll ◀ ▶ buttons to set the time (hrs). You may set the time up to 99 hours.



6. Press the select ✓ button to activate the option.

The display, indicators and dial halos will be unlit and unresponsive, but the oven will bake until you quit Sabbath setting.

To quit Sabbath setting

Press and hold the cancel × button until the time of day appears in the display and the oven turns off.

CARE AND CLEANING

DOS

- Before any manual cleaning or maintenance, first wait for the oven to cool down to a safe temperature to touch, then disconnect it from the power supply.
- Read these cleaning instructions and the 'Safety and warnings' section before you start cleaning your oven.
- See the following pages for instructions on removing and refitting different parts of the oven for cleaning.
- To prevent soiling from becoming 'baked on' and stubborn, we recommend removing any spills, food or grease stains from the oven cavity enamel after each use.
- Always clean the inner glass pane before starting a Self Clean cycle (where available).

DON'TS

- Always remove oven shelves and sideracks before starting a Self Clean cycle (where available).
- Don't use a steam cleaner.
- Don't keep flammable substances in the oven.
- Don't use or any abrasive or harsh cleaners, cloths, scouring pads or steel wool. Some nylon scourers may also scratch. Check the label.
- Don't leave alkaline (salty spills) or acidic substances (such as lemon juice or vinegar) on the oven surfaces.
- Don't use cleaning products with a chlorine or acidic base.

WHAT?

Glass surfaces
(oven door panes, control panel)

HOW?

Door comprises a total of 4 glass panes

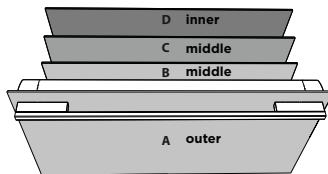

- To clean glass pane B-D, you will first need to remove the door and the panes. For instructions, see page 31.
 1. Clean with a solution of mild detergent or baking soda and hot water, then wipe dry.
 2. Wipe with a glass cleaner and dry with a soft, lint-free cloth.

IMPORTANT!

Don't use oven cleaners or any other harsh/abrasive cleaners, cloths, scouring pads, steel wool or sharp metal scrapers to clean the glass surfaces. These scratch the glass and may damage its special coating, which in turn could result in the glass cracking or shattering.

Even if you only clean the inner pane (D), remove the door and the pane first.

Cleaning the glass with the pane in the door may result in cleaning liquid running down the gaps and drying onto internal components.

Take particular care when cleaning the control panel glass. Only use a damp cloth with detergent.

Dials

Clean with a solution of mild detergent and hot water, then wipe dry.

Do not use stainless steel or oven cleaner, scouring pads, steel wool or abrasive items on the dials as doing so may damage their coating.

CARE AND CLEANING

Manual cleaning

WHAT?	HOW?	IMPORTANT!
Oven	<p>To clean light soiling off the enamelled surfaces:</p> <ol style="list-style-type: none"> 1. Wipe with a damp cloth and a solution of hot water and mild detergent. 2. Wipe dry with a soft cloth. <p>To clean stubborn, 'baked on' soiling or the whole oven cavity:</p> <p>Use the Self Clean function. See 'Using the Self Clean function' for instructions.</p>	<ul style="list-style-type: none"> • To prevent soiling from becoming 'baked on' and stubborn, we recommend removing any easy -to -reach spills, food or grease stains from the enamelled surfaces after each use. Doing so will reduce the need for using the Self Clean function frequently.
Grill tray Grill rack Side racks Oven shelves Rotisserie parts Baking tray	<p>Clean with a solution of mild detergent and hot water.</p> <p>Pre-soak stubborn burnt-on stains.</p> <p>Except for the baking tray, these parts are also dishwasher safe.</p>	<p>You don't need to remove the four lock studs from the grill tray. They can be soaked and cleaned while fixed to the tray.</p> <ul style="list-style-type: none"> • Never leave any of these parts in the oven during a Self Clean cycle. They will get discoloured or damaged.
Oven seal	Do not clean this part.	
Oven vent louvres	Wipe with a damp cloth.	Take care not to let any liquid run down the louvres of the oven vent.

CARE AND CLEANING - DROP DOWN GRILL

Drop-down grill element

Important!

Turn off the oven at the wall and wait until the element has cooled completely before starting.

- To lower the grill element: use a flat-head screwdriver or a small coin to loosen the element fixing screws.
- When you have finished cleaning the oven ceiling, raise the grill element and screw the element fixing screws back onto the studs. Make sure that the fixing screws are tightened and the element is held securely in place.
- The grill element itself is self-cleaning.

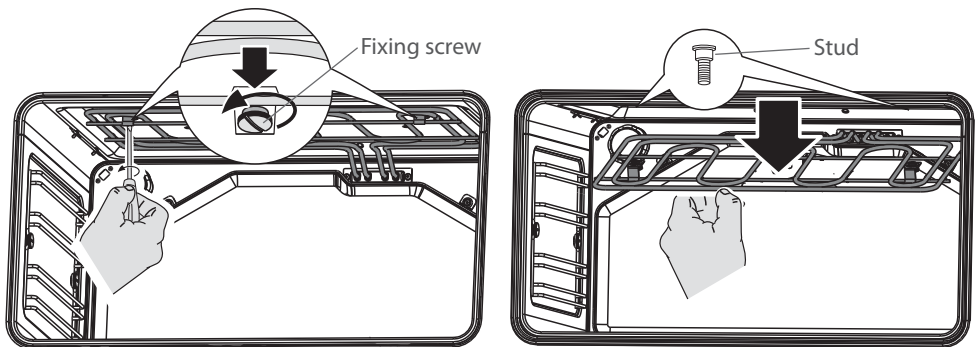

CARE AND CLEANING - REMOVE RACKS

Removing and replacing the side racks

- Use a flat-head screwdriver or a small coin to loosen the fixing screws.
- When replacing the side racks, make sure that you tighten the fixing screws.

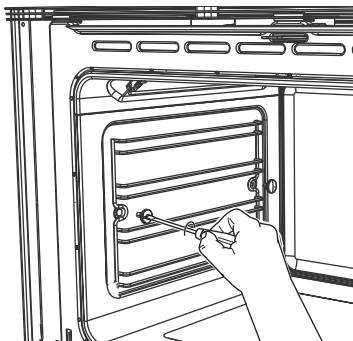

Removing and refitting the sliding shelf supports

IMPORTANT!

- Remove the side racks first to make removing the sliding shelf supports easier.
- The sliding shelf supports can only be used on shelf position 1, 3 and 4. They cannot be used on shelf position 2.

When refitting the sliding shelf supports, make sure that you fit:

- the side racks first
- the slides to the top wire of the shelf position
- both sides of each pair of slides
- both slides on the same level.

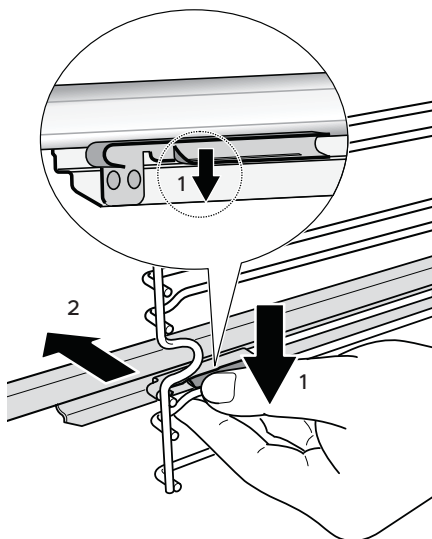

Removing the sliding shelf supports

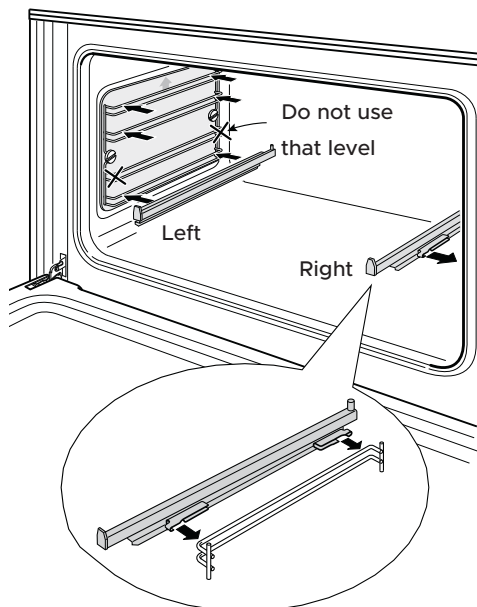

Refitting the sliding shelf supports

CARE AND CLEANING - REMOVE DOOR

Removing the oven door

We recommend to remove the door to easily clean the interior parts of the oven or replace the light bulb(s).

Important!

- Be careful when removing the door. If you are not sure, do not attempt to remove the door.
- Ensure the oven and all its parts have cooled down. Do not attempt to handle the parts of a hot oven.

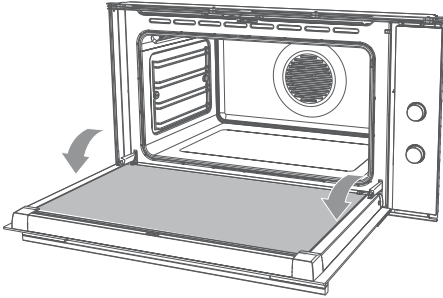

1. Ensure you have prepared enough space for resting the door and its glass panes on a clean, flat surface.
2. Open the door to its full extent.

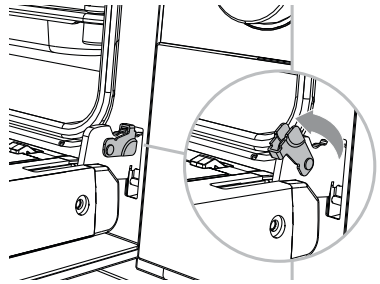

3. Open the levers on the left and right hinges to their full extent, as shown.

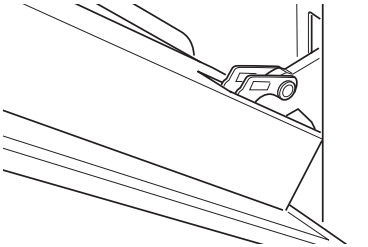

4. Gently close the door until the left and right hinge levers are hooked to the door.

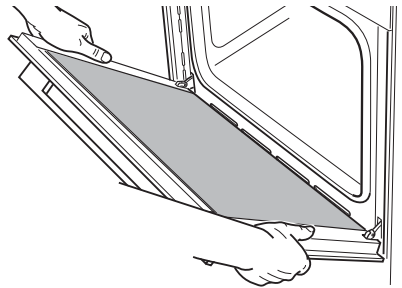

5. Hold the door firmly, as shown.

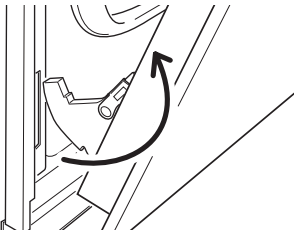

6. Lift the door and disengage the hinges. Rest the door on a soft surface. Ensure you lay it with the handle side down.

CARE AND CLEANING - REMOVE GLASS

During the Self Clean Cycle, if soiling is left on the glass, it will become burnt making it very difficult to remove.

Removing and replacing the door glass panes for cleaning

The oven door has four panes of glass.

The inner and middle panels can be removed to make cleaning the glass easier.

Important!

- the oven door is heavy (14 kg). If you have any doubts, do not attempt to remove the door.
- Take extreme care when handling the glass pane. Avoid the edges of the glass bumping against any surface. This may result in the glass shattering.
- Don't use oven cleaners or any other harsh/abrasive cleaners, cloths, scouring pads, steel wool or sharp metal scrapers to clean the glass surfaces. These scratch the glass which in turn could result in the glass cracking or shattering.
- If you notice any sign of damage on any of the glass panes (such as chipping or cracks), do not use the oven. Call your Authorised Repairer or Customer Care.
- Ensure you replace the inner glass pane correctly. Do not use the oven without the inner glass pane correctly in place.
- If the glass panes feel difficult to remove or replace, do not force it. Call your Authorised Repairer or Customer Care for help. Note: service visits providing assistance with using or maintaining the oven are not covered by your warranty. **Note: service visits providing assistance with using or maintaining the oven are not covered by your warranty.**

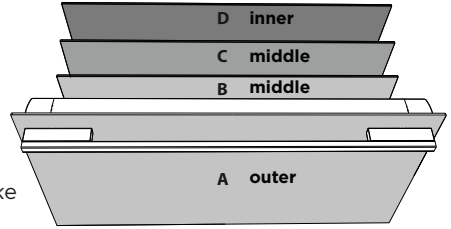

To remove the inner glass panes

1. Remove the oven door following the instructions. Lay it on a protected surface with the handle down.

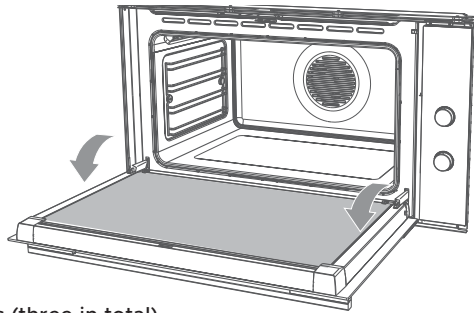

Remove the inner and middle glass panes (three in total)

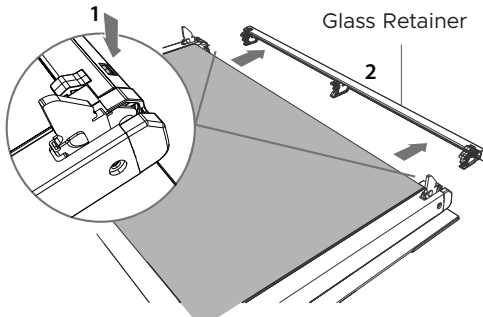

1. Press down on both tabs (1) to release the glass retainer (2).

2. Lift the inner pane (D) slightly (1), then gently slide out (2).

CARE AND CLEANING - REMOVE GLASS

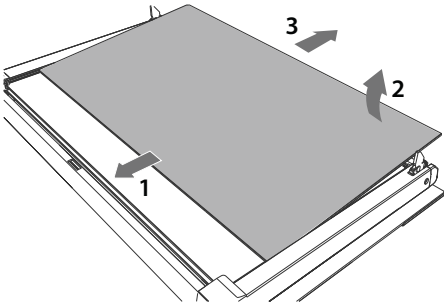

3. Slide the first middle pane (C) slightly towards yourself (1), then lift (2) and slide out (3).

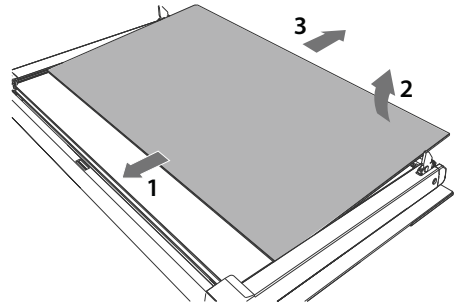

4. Slide the second middle pane (B) slightly towards yourself (1), then lift (2) and slide out (3).

CARE AND CLEANING - REFIT GLASS

After cleaning, replace the glass panes

When replacing the glass panes, make sure that:

- All three panes are replaced correctly, as shown. Each pane must be in the position described below in order to fit into the door and to ensure that the oven operates safely and correctly
- Extra care is taken not to bump the edges of the glass against any object or surface
- Panes are not forced into place. If you are experiencing difficulties replacing the panes, remove them and start the process again from the beginning. If this still does not help, call Customer Care.

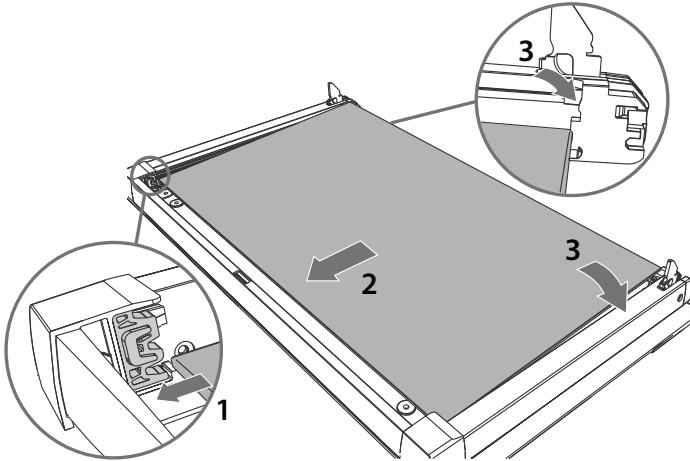

1. Take either one of the middle panes (B or C) and hold it firmly. Insert it in the lowest pair of grooves (1), push it slightly towards yourself (2) and gently lower into place (3). Note: the two middle panes (B and C) are identical.

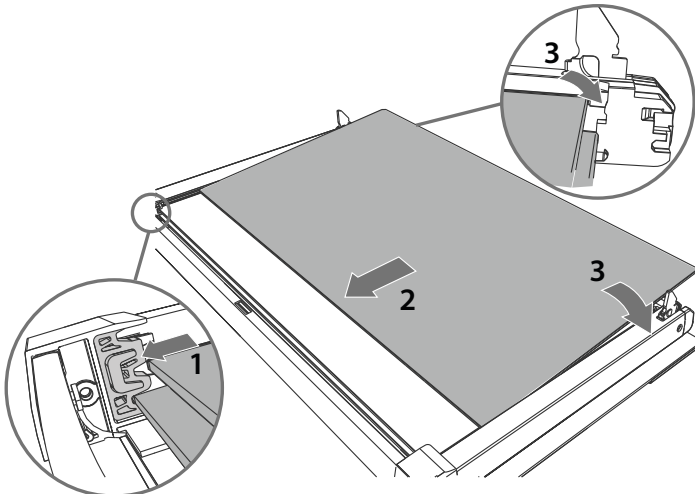

2. Take the other middle pane and hold it firmly. Insert it in the next pair of grooves (1), push it slightly towards yourself (2) and gently lower into place (3).

CARE AND CLEANING - REFIT GLASS

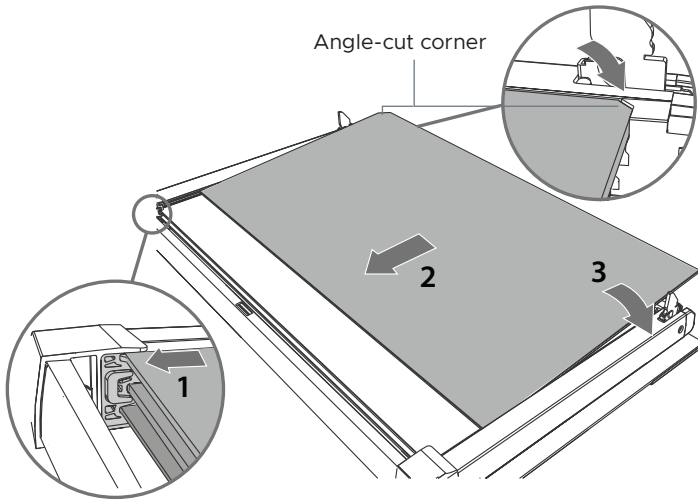

3. Take the inner pane (D), holding it with the angle-cut corner orientated as shown. Insert it in the uppermost pair of grooves (1), push it slightly towards yourself (2) and gently lower into place (3).

IMPORTANT!

Make sure that the angle-cut corner of the inner pane (D) is at the bottom of the oven door, on the left-hand side. It has to be in this position for the door to function correctly.

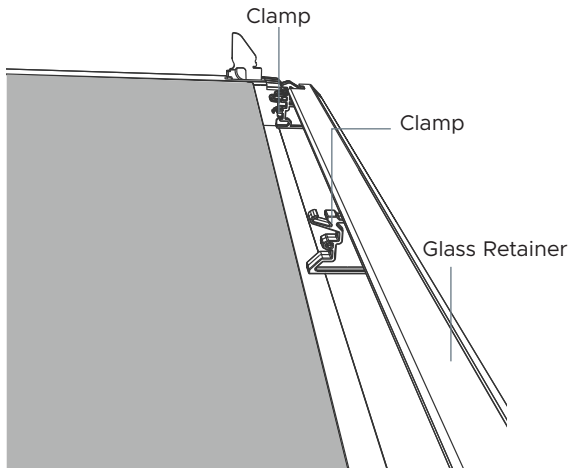

4. Position the glass retainer, as shown. It should sit on the bottom edge of the outer glass (A). Check that the clamps of the glass retainer are not deformed or damaged.

CARE AND CLEANING - REFIT GLASS

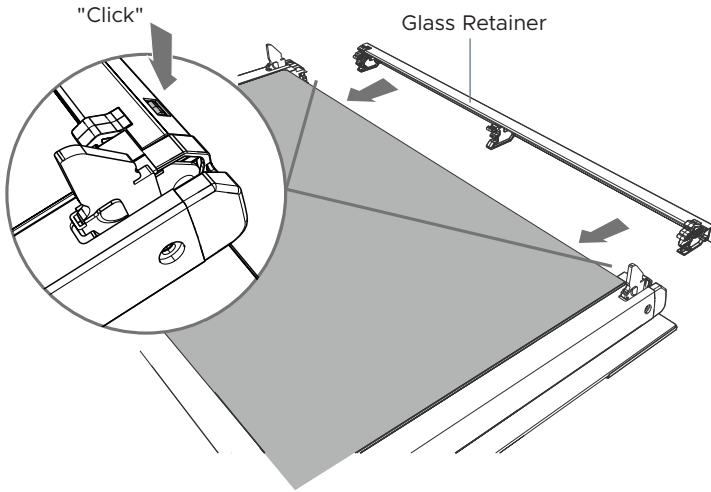

5. Gently push the glass retainer back into place. You should be able to hear the tabs on both sides click as they lock the glass retainer in.
6. Refit the door

IMPORTANT!

Make sure the glass retainer is correctly and firmly in place and that the glass panes are secure.

CARE AND CLEANING - REFIT DOOR

Refitting the door

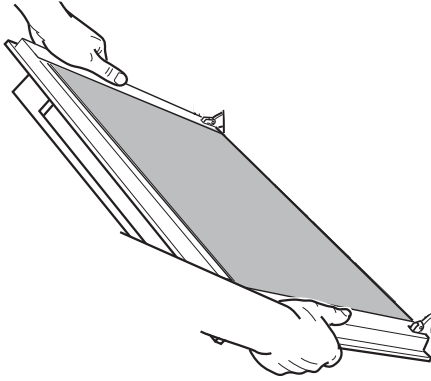

1. Hold the door firmly.

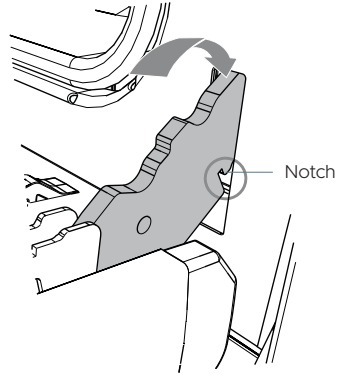

2. Insert the hinge tongues into the slots, making sure that the notches on both sides drop into place as shown.

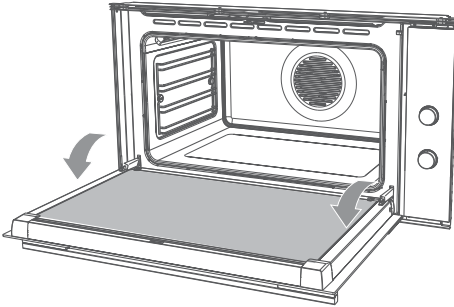

3. Open the door to its full extent.

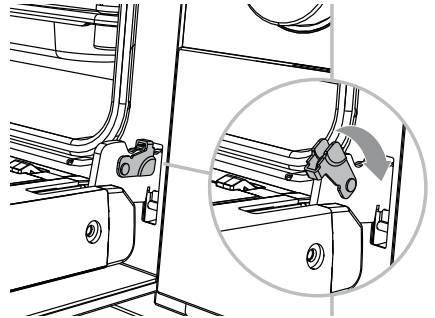

4. Fully close the levers on the left and right hinges, as shown.

5. Close the door and check that it is properly in place: it should sit square to the oven vent louvres and the control panel.

PREPARING TO USE THE SELF CLEAN FUNCTION

- During the pyrolytic Self Clean cycle the extremely high temperature burns off and breaks down grime and grease deposits. All that is left is a small amount of grey ash that you can easily remove.
- There is a choice of Self Clean cycles:
- Self Clean (3 hours) (for normal soiling).
- Light Self Clean (2 hours) (suitable for a light or localised soiling).

IMPORTANT!

- You must clean the inside glass door panel **BEFORE** starting a self-clean cycle. Failure to do this may result in permanent staining or marking of the door glass.
- Do not use oven cleaners, any degreasing cleaners, or oven liners.
- Make sure you remove the side racks, oven shelves and trays, rotisserie and all other bakeware and utensils from the oven before starting a Self Clean cycle. If left in the oven, they will become permanently discoloured or damaged; items made from combustible materials (e.g. wood, fabric, plastic) may even catch fire.
- Do not use your oven to clean miscellaneous parts.
- Make sure the room is well ventilated.
- Before starting a Self Clean cycle, make sure you move any pet birds to another, closed and well-ventilated room. Some pet birds are extremely sensitive to the fumes given off during a Self Clean cycle, and may die if left in the same room as the oven during such a cycle.
- During a Self Clean cycle, the oven reaches higher temperatures than it does for cooking. Under such conditions, the surfaces may get hotter than usual and children should be kept away.
- The oven door will be locked during the Self Clean cycle (approximately 3 hours).
- If there are cracks or flaws on any of the oven door glass panes, if the oven seal is damaged or worn, or if the door does not close properly, do not start a Self Clean cycle. Call your Authorised Repairer or Customer Care.

To start a Self Clean cycle

1. Remove oven shelves, side racks and all other accessories, bakeware, and utensils.
 - Wipe up any spills. Failure to do so may discolour the oven surfaces.
 - Check the inner glass pane of the oven door (D). If it has soiling on it (e.g. stains from greasy splatter), you will need to clean it manually before starting a Self Clean cycle.
 - For instructions, see 'Care and cleaning'.

Important

If soiling is left on the glass, it will become burnt on during the Self Clean cycle, making it very difficult to remove.

2. Close the oven door firmly.

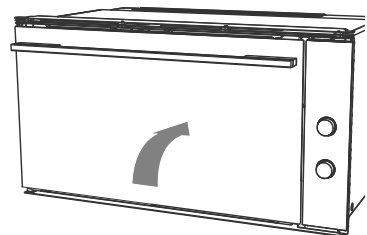
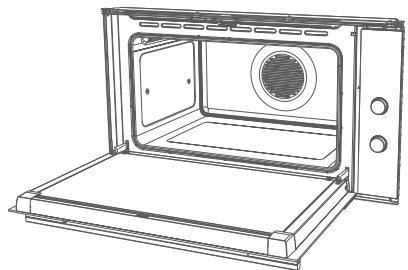

USING THE SELF CLEAN FUNCTION

1. Select the Self Clean function. The display will flash 0:00



2. Press the right scroll button once for the **Self Clean** cycle - the display will flash 3:00 (3 hours), or

Press the right scroll button a second time for the Light Self Clean cycle - the display will flash 2:00 (2 hours)

The temperature indicator will be blank, as temperature cannot be adjusted.

FUNCTION



0:00

3. Press the select button to start the Self Clean cycle.

- The time will start counting down.
- For your safety, the oven door will automatically lock and remain locked during the cycle.
- Note: if the select button is not pressed within 15 seconds, the oven will automatically turn off. Start from step 3 again.
- The display will show **DOOR** if the door is not shut properly. See 'Troubleshooting'.
- If the door is not shut properly within 30 seconds, the oven will automatically turn off.



3:00



During the Self Clean cycle

- the temperature and function halos will remain off.
- the Self Clean  function will be lit.
- the display will countdown the time remaining.
- the cancel button will glow red.

3:00



USING THE SELF CLEAN FUNCTION

When a Self Clean cycle has finished

The oven will:

- emit a long tone
- automatically turn off
- automatically unlock the door.

In a few seconds, the display will show the time of day.

You need to:

1. wait for the oven to cool down completely
2. remove the grey ash with a small brush or damp cloth
3. wipe out the oven with a clean damp cloth
4. dry with a clean lint-free cloth
5. replace the side racks and shelves.

To cancel a Self Clean cycle

IMPORTANT!

- A Self Clean cycle can be cancelled at any time by pressing the cancel button.
- The door will not unlock until the oven has cooled to a safe temperature. Do NOT turn off the mains power supply to the oven (wall switch). Turning off the power while the oven is too hot may damage the oven and its surrounding cabinetry.

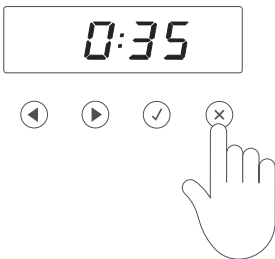

To cancel a Self Clean cycle, press the cancel button.

- If the oven needs to cool down, the Self Clean function indicator will stay lit, the display will show the remaining cool-down time, the temperature indicator will show cascading bars  and the door will remain locked.
- When it has cooled down, the oven will turn off, the door will unlock, a long tone will sound and the display will show the time of day.
- We do not recommend cancelling a Self Clean cycle and then immediately starting one again.

REPLACE OVEN LIGHT BULB

Replacing the oven light bulbs

The oven light bulbs (12V/20 W halogen) have a very long life, but if you should need to replace one, use only a replacement bulb purchased from your nearest Fisher & Paykel dealer and follow these steps.

Note: oven bulb replacement is not covered by your warranty.

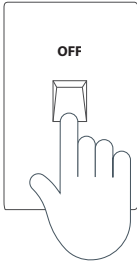

1. Allow the oven to cool down, then turn it off at the mains power supply (wall switch).

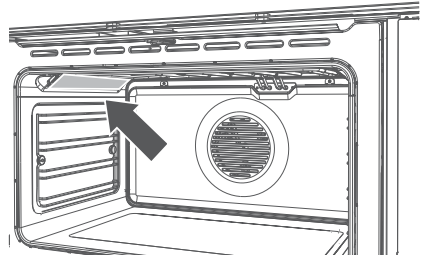

2. Remove any oven shelves that may get in the way.

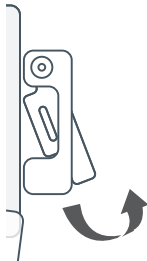

3. Using a flat-head screwdriver, twist and lift the retainer clip upwards to release the glass cover. Hold the glass cover to prevent it falling.

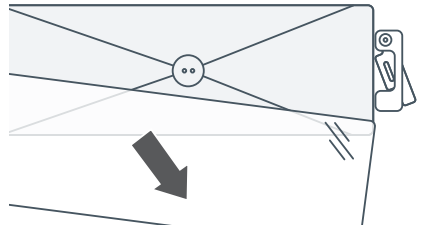

4. Carefully lift the glass cover out of the retaining bracket in the back and pull out the faulty bulb.



5. Hold the replacement bulb in a soft cloth or tissue (touching the bulb will reduce its life span) and insert it into the socket.

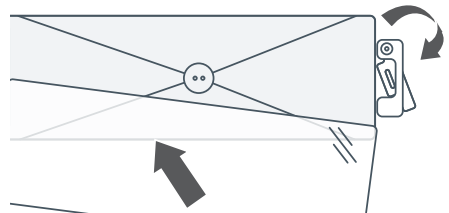

6. Reposition the glass cover and twist the retainer clip back in place. Turn the oven back on at the mains power supply (wall switch).

TROUBLESHOOTING

Troubleshooting chart



If there is a problem, check the chart below to see if you can fix it. If the problem cannot be fixed or persists, call your Authorised Repairer or Customer Care.

PROBLEM	POSSIBLE CAUSES	WHAT TO DO
GENERAL		
The oven does not work	No power.	Check that the mains power supply (wall switch) is turned on, the fuse has not tripped and there is no power outage in your area.
The lights do not come on when I open the oven door	The oven light bulb(s) have blown.	Replace the light bulb(s). See 'Care and cleaning' for instructions.
	The door is not correctly fitted.	See 'Care and cleaning' for instructions on fitting the door correctly.
	The oven is in Sabbath setting and the 'Light off' option has been saved.	To quit Sabbath setting, press and hold the cancel × button. See 'User preference settings' for instructions on changing the 'Light off' option.
The temperature indicator shows — and the dials and buttons are unresponsive	The control panel is locked.	Press and hold the select ✓ or cancel × button to unlock the control panel.
The oven is not heating	The door is not properly closed or it is opened too frequently during cooking.	The heating elements are disabled while the door is open. Ensure the door is properly closed and avoid opening it frequently during cooking.
A glass pane in the oven door has cracked, chipped, or shattered	Incorrect cleaning or the edge of the glass hitting against something.	You must NOT use the oven. Call your Authorised Repairer or Customer Care.

TROUBLESHOOTING

PROBLEM	POSSIBLE CAUSES	WHAT TO DO
General		
The oven has reached the set temperature but the temperature dial halo is still red (indicating that the oven is not ready to use)	This is normal: when heating up from cold, your oven is designed to initially heat to a temperature somewhat higher than what you have set. This is to provide optimal baking conditions right from the start.	Wait until a long tone sounds and the temperature dial halo turns white: the oven will then be ready to use.
The oven is heating but the display is dark	The oven is set to 'Display off' option.	To quit the 'Display off' option, press and hold the cancel × button until the display shows the time of day.
	The oven is in Sabbath setting.	To quit Sabbath setting, press and hold the cancel × button until the display shows the time of day.
The oven cancels automatic cooking when I try to adjust the clock setting	The oven was set for automatic cooking when you were trying to adjust the clock setting.	You can only adjust the clock setting while the oven is not set for automatic cooking. See section 'Setting the clock and first use' for instructions.
The oven beeps when I try to turn the temperature dial OFF or below a certain temperature	This is normal: for food safety reasons, the oven functions have factory-set minimum temperature settings.	The temperature dial itself cannot be 'turned off'. Selecting Off with the function dial will turn the oven off.
The temperature dial halo never turns white when I use Grill	This is normal: the halo stays red to indicate that the grill element provides instant radiant heat.	
The rotisserie skewer will not rotate	The skewer did not fully engage in the rotisserie drive.	Ensure the skewer is pushed fully into the rotisserie drive hole.
	The meat is too heavy.	To get a finish similar to a rotisserie for pieces of meat or poultry heavier than 6 kg, use the grill tray and rack and the Roast function.
The rotisserie skewer stops rotating when I open the door	This is normal: the rotisserie drive is disabled while the door is open.	

TROUBLESHOOTING

PROBLEM	POSSIBLE CAUSES	WHAT TO DO
Self Clean function		
During a Self Clean cycle, the oven is louder than usual.	During a Self Clean cycle, the oven is louder than usual.	
The display shows DOOR.	The oven door is locked because the oven is still too hot to be used for cooking.	Wait until the Self Clean cycle has finished. If you cancelled a Self Clean cycle which was already underway, the oven still needs to cool down before it can be used. The oven door will automatically unlock.
At a point during a Self Clean cycle, the function dial halo goes out and the temperature indicator starts displaying cascading bars 	This is normal: the oven is in the last phase of the Self Clean cycle, cooling down.	Wait until the Self Clean cycle has finished. A long tone will sound and the oven door will automatically unlock when the oven is ready to use.
The oven beeps when I try to turn the temperature dial OFF or below a certain temperature	This is normal: for food safety reasons, the oven functions have factory-set minimum temperature settings.	The temperature dial itself cannot be 'turned off'. Selecting Off with the function dial will turn the oven off.
I have cancelled a Self Clean cycle but cannot use the oven: - the oven door will not open - the display is still counting down minutes or showing  - the Self Clean function indicator is still lit - the temperature indicator shows cascading bars  - the dials and buttons are unresponsive.	This is normal: if the function dial halo is unlit, you have successfully cancelled the Self Clean cycle. However, the oven is still too hot to be used for cooking and needs to cool down.	Wait until the cool-down phase has finished. A long tone will sound and the oven door will automatically unlock when the oven is ready to use. Note: depending on when the Self Clean cycle was cancelled, the cool-down phase may take up to 45 minutes.w
The oven is beeping and the display shows A2 or A3 .	See section 'Alert codes' for instructions.	

ALERT CODES

If there is a problem, the oven will:

- automatically suspend all oven functions
- beep five times
- display an alert code.

IMPORTANT!

Do not turn off the mains power supply to the oven (wall switch) if you get an alert code, unless the instructions in the chart following specifically instruct you to. There are cooling fans within the oven which are needed to cool the oven's components. Turning off the power while the oven is too hot may damage the oven and its surrounding cabinetry.

What to do if an alert code is displayed

1. If the beeping hasn't stopped already, press any button to stop it.
2. Make a note of the alert code displayed. You may need this information.
3. Check the chart following to see if you can fix the problem yourself and follow the instructions.
4. If you can fix the problem and the alert code does not reappear, you can keep using your oven.

OR

If you can't fix the problem yourself or the alert code reappears and the problem persists: wait until the cooling fans have stopped and the oven has completely cooled down, then turn the power to the oven off at the wall and call your Authorised Repairer or Customer Care with the alert code information.

ALERT CODES

ALERT CODE	POSSIBLE CAUSES	WHAT TO DO
A1	The oven has overheated.	<ol style="list-style-type: none">1. Allow the oven to cool down.2. Once the oven has cooled down and the door has unlocked, the alert code will disappear. You can now use the oven again.
A2	Door lock error: the door cannot be locked after you have started a Self Clean cycle.	<ol style="list-style-type: none">1. Turn the power to the oven off at the wall and on again.2. Wait approximately 10 seconds. This is to allow the door lock to return to its initial position.3. Set the clock. See 'Setting the clock and first use' for instructions.4. Try starting a Self Clean cycle again, making sure that you close the door firmly. See 'Using the Self Clean function'.
A3	Door lock error: the door cannot be unlocked after a Self Clean cycle has finished.	<ol style="list-style-type: none">1. Turn the power to the oven off at the wall and on again.2. Try pressing on the oven door to help the door lock disengage.3. If this doesn't help and the alert code reappears, call your Authorised Repairer or Customer Care.
F + number	Technical fault.	<ol style="list-style-type: none">1. Note down the alert code.2. Wait until the cooling fans have stopped and the oven has completely cooled down.3. Turn the power to the oven off at the wall.4. Call your Authorised Repairer or Customer Care with the alert code information.



To access your Warranty and Service Guide

Scan the QR code with your smartphone to access your warranty and book a service, or view online at:

New Zealand

<https://www.fisherpaykel.com/nz/help-and-support/warranty-information>

Australia

<https://www.fisherpaykel.com/au/help-and-support/warranty-information>

Singapore

<https://www.fisherpaykel.com/sg/help-and-support/warranty-information>

This product has been designed for use in a domestic (residential) environment. This product is not designed for any commercial use. Any commercial use by the customer will affect this product's Manufacturer's Warranty.

For spare parts, please contact Fisher & Paykel Customer Care. Spare parts are available for all Fisher & Paykel products for a minimum period of 10 years from the date of manufacture.

CUSTOMER CARE

Before you call for service or assistance

Check the things you can do yourself. Refer to your User guide and check:

- ① Your product is correctly installed.
- ② You are familiar with its normal operation.
- ③ You have read the 'Alert codes' and 'Troubleshooting' sections.

If after checking these points you still need assistance or parts, please refer to your nearest Fisher & Paykel trained and supported service technician, Customer Care, or contact us through our website fisherpaykel.com.

In NZ if you need assistance

Call the Fisher & Paykel Customer Care Centre and talk to one of our Customer Care Consultants.

Phone: 0800 372 273

Website: fisherpaykel.com

Email: customer.care@fp.co.nz

Postal address:

Fisher & Paykel Appliances New Zealand,
PO BOX 58546, Botany, Auckland
New Zealand

In Australia if you need assistance

Call the Fisher & Paykel Customer Care Centre and talk to one of our Customer Care Consultants.

Phone: 1300 650 590

Website: fisherpaykel.com

Email: customer.care@fp.com.au

Postal address:

Fisher & Paykel Appliances Australia
Level 1, 1 Eden Park Drive
Macquarie Park, NSW2113
Australia

In Singapore if you need assistance

Call the Fisher & Paykel Customer Care Centre and talk to one of our Customer Care Consultants.

Phone: +65 6741 0777

Website: fisherpaykel.com

Email: sg.customercare@fisherpaykel.com

Postal address:

Fisher & Paykel Appliances
51 Kampong Bugis
#01-05 Kallang Riverside Condominium
Singapore 338986

CUSTOMER CARE

If you need service

Fisher & Paykel has a network of Fisher & Paykel trained and supported service technicians that can carry out any service necessary on your appliance. Our Customer Care Centre can recommend a Fisher & Paykel trained and supported service technician in your area. Or you can book one online at fisherpaykel.com/uk/help-and-support, fisherpaykel.com/ie/help-and-support, fisherpaykel.com/eu/help-and-support or fisherpaykel.com/sg/help-and-support

If you call, write or contact us via our website please provide:
your name and address, model number, serial number, date of purchase and a complete description of the problem. This information is needed in order to better respond to your request for assistance.

Complete and keep for safe reference:

Model _____

Serial No. _____

Purchase Date _____

Purchaser _____

Dealer _____

Suburb _____

Town _____

Country _____

FISHERPAYKEL.COM

© Fisher & Paykel Appliances 2026. All rights reserved.

The models shown in this guide may not be available in all markets
and are subject to change at any time.

The product specifications in this guide apply to the specific products and models described
at the date of issue. Under our policy of continuous product improvement, these
specifications may change at any time.

For current details about model and specification availability in your country, please go to
our website or contact your local Fisher & Paykel dealer.

432372B 05.26