

FISHER & PAYKEL

GAS-ON-GLASS COOKTOP

CG301D, CG302D, CG451D, CG603D, CG604D, CG762D,
CG903D & CG905D models

USER GUIDE
NZ AU UK IE SG

CONTENTS

Introduction	5
Safety and warnings	6
Before you begin	9
Cooktop use	10
Dual wok burner use	12
Cooking guide	13
Care and cleaning	15
Troubleshooting	18
Energy guidelines	20
Energy guidelines (GB & IE only)	21
Warranty and service	23

SAVE THESE INSTRUCTIONS

The models shown in this User guide may not be available in all markets and are subject to change at any time. For current details about model and specification availability in your country, go to our website fisherpaykel.com or contact your local Fisher & Paykel dealer.

Registration

Register your product with us so we can provide you with the best service possible.

To register your product visit our website: fisherpaykel.com

INTRODUCTION

Congratulations on your new purchase. Your Fisher & Paykel gas cooktop gives the ultimate experience in gas cooking with speed and precision. Your cooktop delivers powerful modern functionality with a singular aesthetic treatment. Matte black detailing separates the control panel from the black glass cooking surface, while black burners with anodised black dials and trim complete the look for a cohesive, beautiful hob.

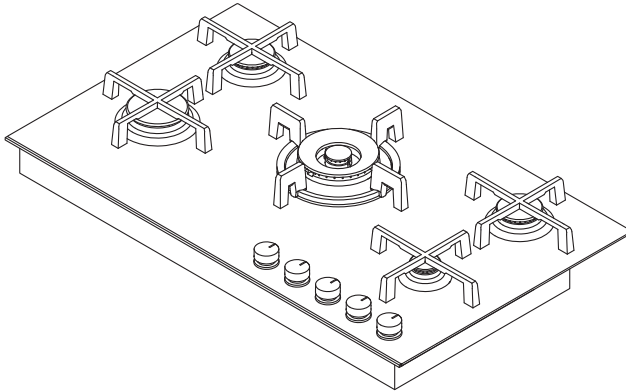

⚠ WARNING!



Electrical Shock Hazard

Failure to follow this advice may result in electrical shock or death.

- Switch the power to the cooktop off at the wall before cleaning or maintenance.
- Do not cook on a broken or cracked cooktop. If the glass should break or crack, turn off the gas supply and switch the appliance off immediately at the mains power supply (wall switch) and contact a qualified technician.

⚠ WARNING!



Fire Hazard

Failure to follow this advice may result in serious injury.

- Never leave the appliance unattended when in use. Boilover causes smoking and greasy spillovers that may ignite.

⚠ WARNING!



Poisoning Hazard

Failure to follow this advice may result in poisoning or death.

- Never use this appliance as a space heater to heat or warm the room. Doing so may result in carbon monoxide poisoning and overheating of the appliance.

⚠ WARNING!



Explosion Hazard

Failure to follow this advice may result in death or serious injury.

- Do not use or store flammable materials such as gasoline near this appliance.
- Do not spray aerosols in the vicinity of this appliance while it is in operation.

⚠ WARNING!



Hot Surface Hazard

Failure to follow this advice may result in serious injury.

- This appliance becomes hot during use. Do not touch the cooktop components, burners, pan supports or the glass when hot.
- Before cleaning, turn the burners off and make sure the whole cooktop is cool.

WARNING!

To reduce the risk of fire, injury to persons or damage when using the appliance, follow the important safety instructions listed below. Read all the guidance before using the appliance.

General Use

- CAUTION: This appliance is for cooking purposes only. It shall not be used for other purposes, for example, room heating.
- Keep children away from the cooktop when it is in use.
- Household appliances are not intended to be played with by children.
- Children of less than 8 years old must be kept away from the appliance unless continuously supervised. This appliance can be used by children aged from 8 years and above, and persons with reduced physical, sensory or mental capabilities or lack of experience and knowledge, if they have been given supervision or instruction concerning the use of the appliance in a safe way and they understand the hazards involved. Cleaning and user maintenance shall not be done by children without supervision.
- If the electrical supply cord is damaged, it must only be replaced by an authorised person.
- If the appliance is connected to the gas supply with a flexible hose, make sure that the hose

SAFETY AND WARNINGS

cannot come in contact with the bottom of the appliance or any sharp edges.

- Ensure that the electrical connection plug is accessible after installation.
- This appliance should be connected to a circuit that incorporates an isolating switch providing full disconnection from the electricity supply.
- Do not use an asbestos mat or decorative covers between the flame and the saucepan as this may cause serious damage to your cooktop.
- Do not place aluminium foil or plastic dishes on the cooktop burners.
- Do not let large saucepans, frying pans or woks push any other pans aside. This could make them unstable or deflect heat onto your benchtop and damage the surface.
- Do not use a steam cleaner for cleaning this cooktop.
- Saucepan handles may be hot to touch. Ensure saucepan handles do not overhang other gas burners that are on. Keep handles out of reach of children.
- Do not stand or place heavy objects on this appliance.
- After use, ensure that the burner dials are in the 'OFF' (o) position.
- Where this appliance is installed in marine craft or in caravans, it shall not be used as a space heater.
- CAUTION: In case the glass surface breaks:
 - Immediately shut off all burners and any electrical heating element, and disconnect the appliance from the power supply.
 - Do not touch the appliance surface.
 - Do not use the appliance.
- Take care not to drop any heavy or sharp objects on the cooktop. The glass is tough, but sharp or heavy objects falling on it (e.g. pepper mill, heavy-based frying pan) may crack or chip it.
- CAUTION: The use of a gas cooking appliance results in the production of heat and moisture in the room in which it is installed. Ensure the kitchen is well ventilated. Keep natural ventilation holes open or install a mechanical ventilation device (mechanical extractor hood). Prolonged intensive use of the appliance may call for additional ventilation, for example opening of a window, or more effective ventilation, for example increasing the level of mechanical ventilation where present. Consult a professional before installation of the additional ventilation.
- After having unpacked the appliance, check to ensure that it is not damaged. In case of doubt, do not use it and consult your supplier or a professionally qualified technician.
- Packing elements (eg plastic bags, polystyrene foam, nails, packing straps, etc.) should not be left around within easy reach of children, as these may cause serious injuries.
- Do not modify this appliance.
- This appliance is to be serviced only by Fisher & Paykel trained and supported service technician or qualified electrician in order to avoid a hazard.
- Some products are supplied with protective film on steel and aluminium parts. This film must be removed before using the appliance.
- Never leave the cooktop unattended when in use. Boil-over causes smoking and greasy spills that may ignite.
- Never allow flames to extend beyond cookware or curl up its sides. This could discolor and damage the utensil and you may get burned touching a hot handle.
- Keep handles out of the way. Turn handles so that they don't extend over the edge of the cooktop or another burner that is on.
- Take care when deep-frying. Oil or fat can overheat quickly, particularly on a high.

BEFORE YOU BEGIN

- Read this guide, taking special note of the 'Safety and warnings' section.
- Remove all packaging from the cooktop. Recycle responsibly.
- Remove any adhesive residue using dishwashing liquid on a soft cloth. Do not use any harsh or abrasive cleaners.

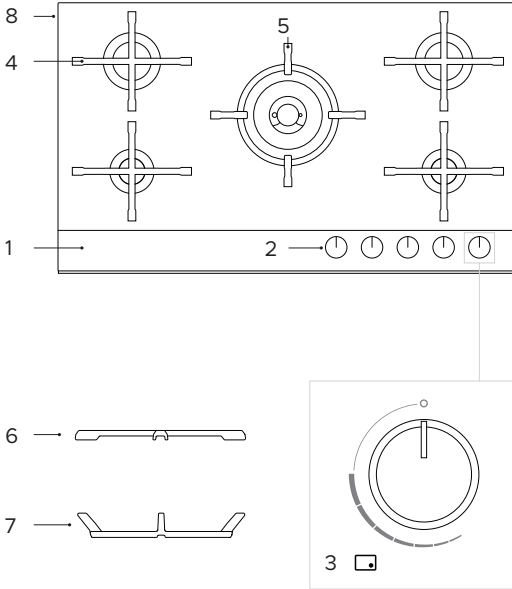

Cooktop features and accessories

- ① Control panel
- ② Burner dials
- ③ Burner indicators
- ④ Pan supports
- ⑤ Dual Wok pan support*
- ⑥ Small pan support*
- ⑦ Wok stand*
- ⑧ Serial label (cooktop base)

CG604D models only: Mini wok pan support (not illustrated)

CG905D model illustrated

COOKTOP USE

Selecting and using the burners

1

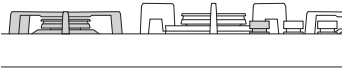

Identify the desired burner and the corresponding dial.

2

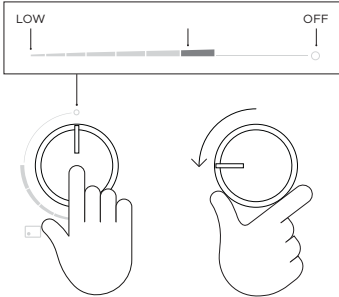

Push the dial down and turn counterclockwise to the highest heat setting. Once the burner is lit, hold the dial down for a further 3 seconds.

Note: a clicking sound should be present when igniting the burner. If no clicking is present, turn the dial clockwise back to O (OFF) and refer to 'Troubleshooting'.

3

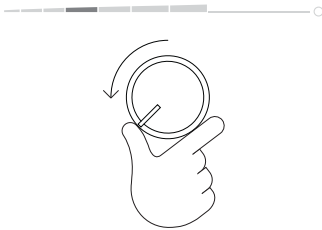

Turn the dial to any heat setting between HIGH and LOW before releasing.

Do not set or leave the dial between HIGH and O (OFF).

4

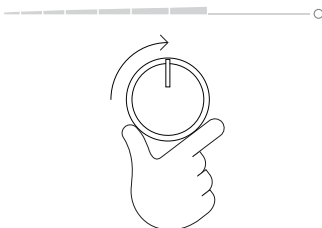

When you have finished cooking, turn the dial clockwise back to O (OFF).

COOKTOP USE

Manual lighting

If the burner will not light after several attempts, the burner can be manually lit. If you have attempted to light the burner with the ignition, allow 1 minute for any accumulated gas to dissipate before manually lighting.

1

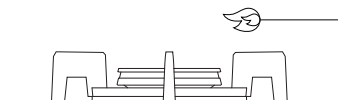

Carefully hold a lit match near the desired burner.

2

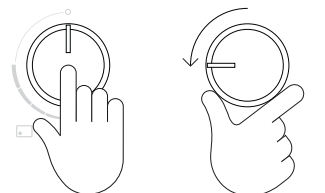

Push the dial down and turn counterclockwise to the highest heat setting. Once the burner is lit continue to hold the dial down for a further 3 seconds.

3

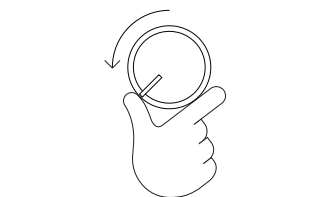

Wait until the flame is burning evenly before turning the dial to any heat setting between HIGH and LOW before releasing.

Do not set or leave the dial between HIGH and O (OFF).

4

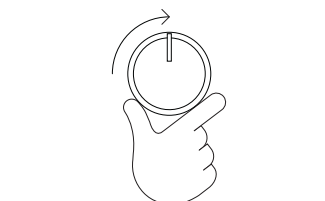

When you have finished cooking, turn the dial clockwise back to O (OFF).

DUAL WOK BURNER USE

When using a dual wok burner, you can choose to use the inner burner only or both the inner and outer burners as desired.

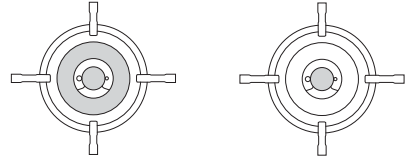

Inner and outer burners

Inner burner only

Adjusting the dual wok burner*

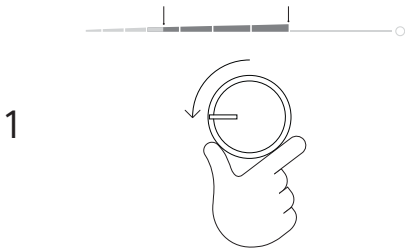

Setting both the inner and outer rings

Turn the dial to any heat setting between MEDIUM and HIGH before releasing.

If the flame on the outer ring appears to flutter, turn the dial slightly towards HIGH to stabilise.

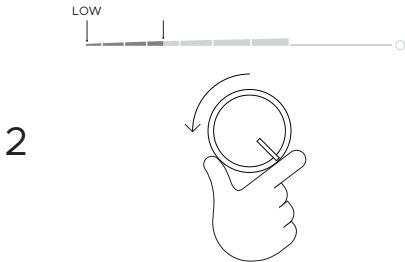

Setting the inner ring

Turn the dial to any heat setting between MEDIUM and LOW before releasing.

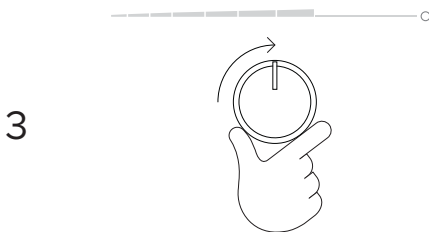

When you have finished cooking, turn the dial clockwise back to O (OFF).

COOKING GUIDE

Cookware

For optimal performance, ensure the size of the cookware is suitable for the burner in use.

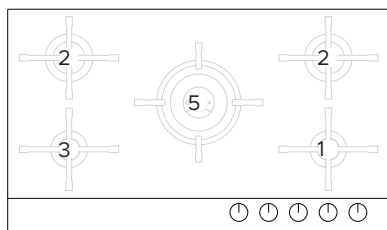

CG905D models

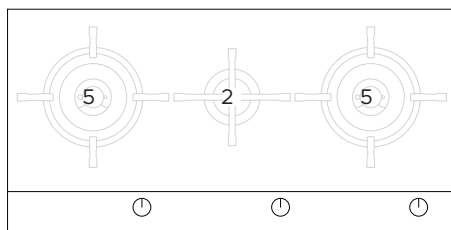

CG903D models

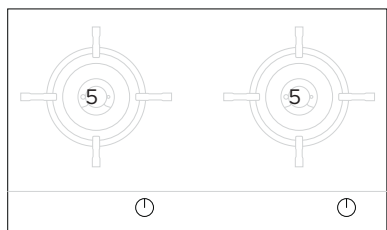

CG762D models

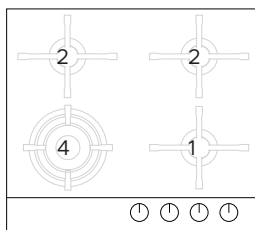

CG604D models

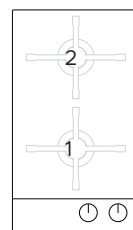

CG302D models

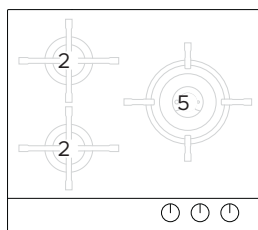

CG603D models

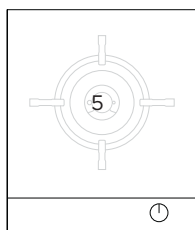

CG451D models

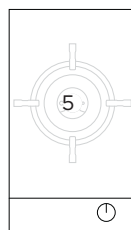

CG301D models

Burner	Min. diameter (mm)	Max. diameter (mm)
① Auxiliary	no minimum	220
② Semi-rapid	100	220
③ Rapid	no minimum	220
④ Mini wok	without small pan support	220
	with wok stand	360
⑤ Dual wok	without small pan support	340
	with wok stand	400

Note: measurements provided from base of pan

Burner supports

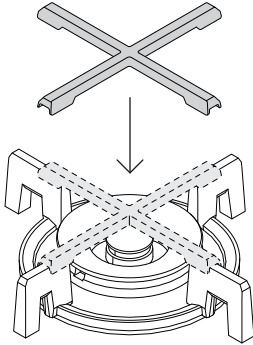

Small pan support

The small pan support has been designed for use with dual wok burners for supporting cookware with a base diameter smaller than 200mm.

Using the small pan support

Ensure cooktop is cool before slotting the small pan support onto the centre of the dual wok burner as shown. Ensure all notches rest securely on the burner pan supports before use.

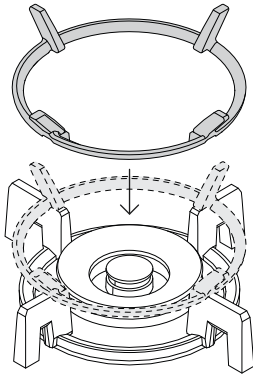

Wok stand

The wok stand has been designed for use with either dual wok and mini wok burners (depending on your model) to allow the safe use of a wok. This accessory must be used when cooking with a wok.

Using the wok stand

Ensure cooktop is cool before slotting the wok stand onto the centre of the dual wok or mini wok burner as shown. Ensure all notches rest securely on the burner pan supports before use.

CARE AND CLEANING

Replacing burner parts

Ensure that all burner parts are correctly fitted. Incorrectly assembled burners may produce dangerous flames. Flames should be blue with no yellow tipping, and burn without fluttering around the burner cap.

Semi-rapid, rapid and auxiliary burners

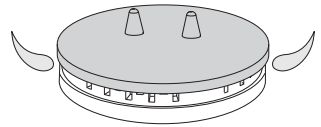
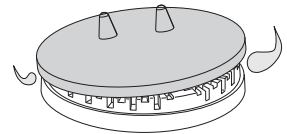
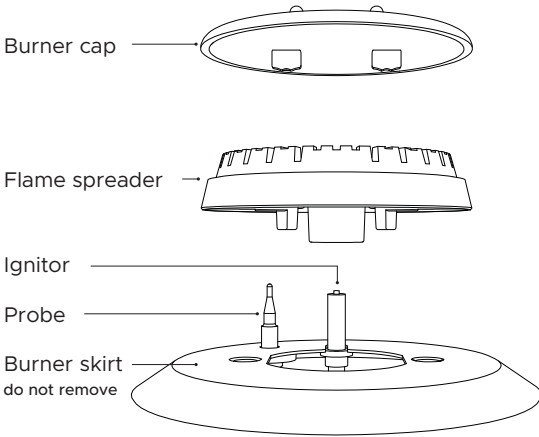

Dual wok and mini wok burners

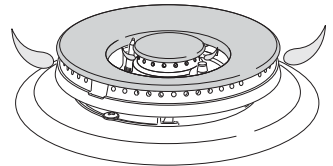
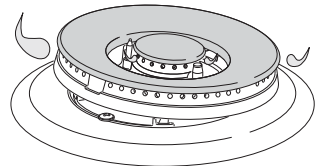
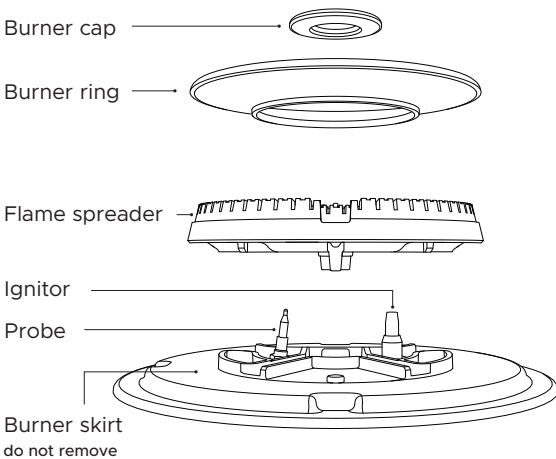

CARE AND CLEANING

Burners

Burners should be cleaned regularly. Food residue may obstruct the ignitor and the notches of the flame spreader, preventing the burner from functioning correctly. Refer to 'Replacing burner parts' for details on safely removing and refitting burner parts.

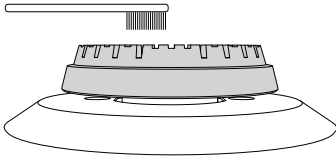

Burner caps, rings, flame spreaders and accessories

- ① Remove the parts that you wish to clean.
- ② Clean in hot soapy water with a stiff nylon brush, stubborn stains can be soaked in powdered dishwasher or laundry detergent. A straight end paperclip can also be used to clear any obstructions from the flame ports.
- ③ Rinse in warm water and dry thoroughly. Ensure all parts are completely dry before refitting as wet burner parts may result in an irregular flame.
- ④ Ensure all parts are replaced correctly.

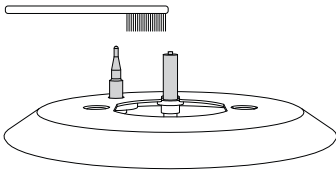

Ignitor and probe

- ① Remove the parts required to access the ignitor and probe.
- ② Clean carefully with a stiff nylon brush dipped in methylated spirits ensuring any build up is removed.
- ③ Ensure all parts are replaced correctly.

All gas components

All checking and maintenance must be performed by a suitably qualified person. If the gas is connected with a flexible hose, checking should include inspecting the entire length of the flexible hose assembly for any sign of wear or damage.

CARE AND CLEANING

Pan supports

Ensure the correct pan support are used for each burner. Pan supports should be installed in the correct orientation.

Semi-rapid, rapid and auxiliary burners

Locate the pan support to the two nodules on the burner cap to secure.

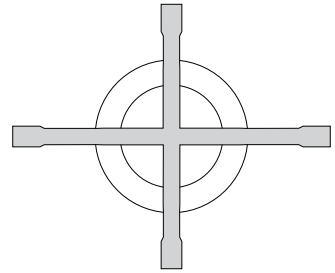
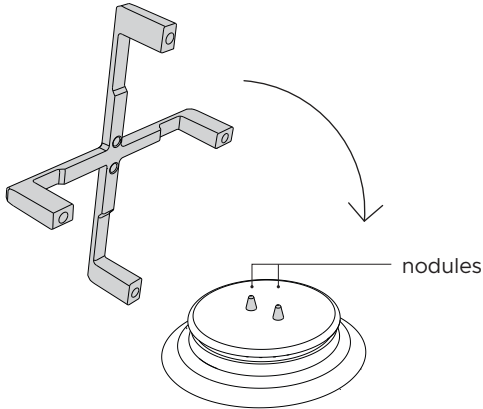

Plan view

Dual wok and mini wok burners

Locate the pan support to the three recesses on the burner skirt to secure.

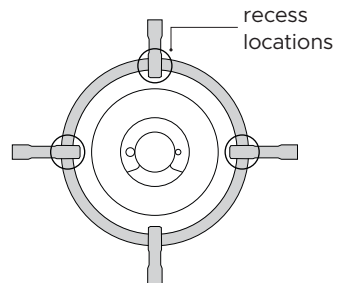
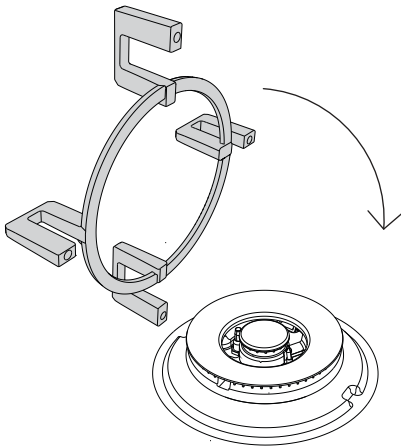

Plan view

TROUBLESHOOTING

PROBLEM	POSSIBLE CAUSES	WHAT TO DO
There is a strong gas smell	The gas connection could be leaking.	Open a window and refer to your installation guide for details on checking for leaks. Do not use the until leak has been repaired.
There is a slight rubbery or metallic smell when I use the cooktop for the first time	This is normal for first use and is caused by manufacturing residues burning off.	The smell will disappear with use.
There is no clicking/ sparking	There is a power failure.	You can still use your cooktop, but will need to match-light the burners. Refer to 'Manual lighting' for details.
	The ignitor may be dirty or wet.	Clean following guidance in 'Care and cleaning'.
There is clicking/sparking, but a burner or burners won't light easily or at all	The gas supply may not be turned on at the valve or gas bottle.	Turn all the burners off, and check whether the gas supply to the cooktop is turned on. Wait 1 minute, then try relighting the burner, holding the dial down for a few more seconds. If the burner still doesn't light, check other possible causes below.
	The gas supply to the house may not be working.	You should hear the gas when you turn a burner on. If you use bottled gas, this may indicate you are getting near the end of the bottle and need to replace it.
	Burner parts may be clogged or wet.	Ensure parts are clean and dry. See 'Care and cleaning' for guidance.
	Burner parts may not have been replaced correctly.	Check the assembly and ensure the burner cap is sitting flat. See 'Replacing the burner parts correctly' for details.
	Dial not held down long enough	Wait 1 minute, then try relighting the burner, holding the dial down for a few more seconds.
The burner goes out after lighting	Blown out by draught	The flame failure protection will automatically cut the gas supply to the burner off, stopping gas from escaping.
	Extinguished by a spill	Turn the affected burner off, then wait for at least 1 minute before attempting to relight. This is to allow for any accumulated gas to disperse.
The flame goes out at low settings	The gas supply pressure may be low.	Check this with your service person or installer.

TROUBLESHOOTING

PROBLEM	POSSIBLE CAUSES	WHAT TO DO
The flames are yellow or yellow-tipped rather than blue	Burner parts (especially the flame ports) may be clogged or wet.	Check that they are clean and dry, refer to 'Care and cleaning' for advice.
	The cooktop may have been connected to the wrong type of gas or the gas pressure is not correct.	Contact Customer Care and do not use your cooktop until it has been checked by a trained and supported service technician.
The flame pattern is uneven around the burner.	Burner parts (especially the flame ports) may be clogged or wet.	Check that they are clean and dry. Refer to 'Care and cleaning' for advice.
	Burner parts may not have been replaced correctly.	Check the assembly and ensure the burner cap and/or ring is sitting flat on the flame spreader. See 'Care and cleaning' details.
The flames are too large, or too small.	The cooktop may have been connected to the wrong type of gas.	Contact Customer Care and do not use your cooktop until it has been checked by a qualified technician.
The flames are noisy.		
The flames lift away from the burner.		
The glass surface of the cooktop has chipped or cracked.		Contact Customer Care and do not use your cooktop until it has been repaired.

ENERGY GUIDELINES

In the United Kingdom:

Safety requirements of EEC regulation 2016/426

- EN 30-1-1
- EN 30-2-1
- EN 437

Safety requirements of EEC Directive “Low voltage” 2006/95:

- EN 60335-1 General Requirements for Domestic electrical appliances
- EN 60335-2-6 Particular Requirements for Domestic electrical cooking appliances

Safety requirements of EEC Directive “EMC” 2004/108:

- EN 55014-1, EN 55014-2, EN 61000-3-2, EN 61000-3-3 Electromagnetic Compatibility Requirements

Requirements of EEC Directive 93/68/EEC and 2011/65/EU

European directive 2012/16/EU on Waste Electrical and Electronic Equipment (WEEE) (for European Union countries only)



GB This appliance is marked according to the European directive 2012/19/EU on Waste Electrical and Electronic Equipment (WEEE). By ensuring this product is disposed of correctly, you will help prevent potential negative consequences for the environment and human health, which could otherwise be caused by inappropriate waste handling of this product.

The symbol  on the product, or on the documents accompanying the product, indicates that this appliance may not be treated as household waste. Instead it shall be handed over to the applicable collection point for the recycling of electrical and electronic equipment. Disposal must be carried out in accordance with local environmental regulations for waste disposal. For more detailed information about treatment, recovery and recycling of this product, please contact your local city office, your household waste disposal service or the shop where you purchased the product.

ULPG Gas Energy Efficiency (%) * of burners with a power of greater than 1.15kW

Burner	CG905DLPGB Efficiency/(no. of burners)	CG604DLPGB1 Efficiency/(no. of burners)	CG603DLPPGB Efficiency/(no. of burners)	CG302DLPGB1 Efficiency/(no. of burners)	CG301DLPGB1 Efficiency/(no. of burners)	CG451DLPGB1 Efficiency/(no. of burners)	CG752DLPGB1 Efficiency/(no. of burners)	CG903DLPGB1 Efficiency/(no. of burners)
Dual Wok/Mini wok	53.8% (1)	53.8% (1)	53.8% (1)	57.4% (1)	57.4% (1)	53.8%	53.8% (2)	53.8% (2)
Semi-rapid	59.4 % (2)	59.4%(2)	59.4% (2)	59.4% (1)				59.4% (1)
Rapid	55.1% (1)							
Auxiliary	57.9% (1)	57.9% (1)		57.9% (1)				59.4% (1)
Energy efficiency (%) of cooktop	57.1%	57.6 %	57.5%	58.7%	57.4%	53.8%	53.8%	55.7%

NG Gas Energy Efficiency (%) * of burners with a power of greater than 1.15kW.

Burner	CG905DNGGB Efficiency/(no. of burners)	CG604DNGGB1 Efficiency/(no. of burners)	CG603DNGPGB Efficiency/(no. of burners)	CG302DNGGB1 Efficiency/(no. of burners)	CG301DNGGB1 Efficiency/(no. of burners)	CG451DNGGB1 Efficiency/(no. of burners)	CG752DNGGB1 Efficiency/(no. of burners)	CG903DNGGB1 Efficiency/(no. of burners)
Dual Wok/Mini wok	56.3 % (1)	56.8% (1)	56.3 % (1)	54.6% (1)	54.6% (1)	56.3 % (1)	56.3 % (2)	56.3 % (2)
Semi-rapid	54.3 % (2)	54.3 % (2)	54.3 % (2)	54.3 % (1)				54.3 % (1)
Rapid	57.3 % (1)							
Auxiliary	na	na	na	na				
Energy efficiency (%) of cooktop	55.6%	55 %	55 %	54.3%	54.6%	56.3 %	56.3 %	55.6%

Energy consumption for gas cooking appliances are calculated using the following Standards:
BS EN 30-2-1 – Rational use of energy - Domestic cooking appliances burning gas

Reducing the environmental impact of cooking

Reducing energy consumption will reduce the impact of cooking on the environment. You can reduce energy consumption by:

- Thawing frozen foods in the refrigerator first
- Using a moderate setting to conserve gas
- Having your burners adjusted by a qualified technician if the flame is yellow
- Ensuring burner parts are clean and dry, as clogged ports will reduce efficiency.
- Using the correct sized pot
- Adjusting the flame correctly – the flame should not extend beyond the edge of the pot
- Using a pressure cooker
- Cutting food into smaller pieces - this will reduce cooking time
- Use a steamer or a pan with a divider to cook different vegetables at the same time
- Using a cover when boiling water to reduce the time it takes to get to the boil.
- Simmering liquid cooked foods instead of boiling vigorously
- Keeping pot lids on to reduce heat loss

WARRANTY AND SERVICE

Before you call for service or assistance

Refer to the installation instructions and your user guide and check that:

- Your product is correctly installed.
- You are familiar with its normal operation.

If after checking these points you still need assistance or parts, please refer to the Service & Warranty book for warranty details and your nearest Service Center, Customer Care, or contact us through our website www.fisherpaykel.com

This cooktop has been designed and constructed in accordance with the following codes and specifications:

In New Zealand and Australia:

- Domestic AS/NZS 5263.1.1- 2016 Gas cooking appliances
- AS/NZS 60335.1 General Requirements for Safety of household and similar electrical appliances
- AS/NZS 60335.2.102 Particular Requirements for gas, oil and solid-burning appliances having electrical connections

Complete and keep for safe reference:

Model _____

Serial No. _____

Purchase Date _____

Purchaser _____

Dealer _____

Suburb _____

Town _____

Country _____

FISHERPAYKEL.COM

© Fisher & Paykel Appliances 2026. All rights reserved.

The models shown in this guide may not be available in all markets
and are subject to change at any time.

The product specifications in this guide apply to the specific products and models described
at the date of issue. Under our policy of continuous product improvement, these
specifications may change at any time.

For current details about model and specification availability in your country, please go to
our website or contact your local Fisher & Paykel dealer.

592137E 05.26