

HRF510BEC - Black

# 500 Series Refrigerator Bottom Freezer



Haier



Height

1725mm

Width

790mm

Depth

707mm

Weight (Packaged)

120.5kg

Weight (Product)

111kg

## OVERVIEW

The 500 Series Refrigerator Bottom Freezer is designed for fresh food lovers, offering a 70:30 fridge-freezer split, advanced cooling, and energy-efficient performance. With clever storage and thoughtful features, including a non-plumbed water dispenser and auto-ice function (select models), it's built for everyday convenience.

## FEATURES

- Energy efficient 8-star rating
- 70:30 fridge-freezer split offers more space for fresh food
- Flat door design with a recessed handle for a clean, modern aesthetic
- Reversible door hinge allows flexible installation to suit different kitchen layouts
- Full-width shelves and spacious compartments provide flexible storage
- LED lighting illuminates the interior for clear visibility and easy access
- Super Freeze function rapidly locks in freshness, preserving taste and texture
- Humidity Zone™ drawer locks in moisture to keep fruit and vegetables fresh

The models shown in this Specification Guide (SG) may not be available in all markets and are subject to change at any time. Product specifications may vary from those shown. This SG should not be used as installation guidance for any product. Further information is required to safely and correctly install the products featured here. Specific installation guidance will be available with the product on delivery and on our website [haier.com](http://haier.com)

# Product Overview

## PRODUCT DIMENSIONS

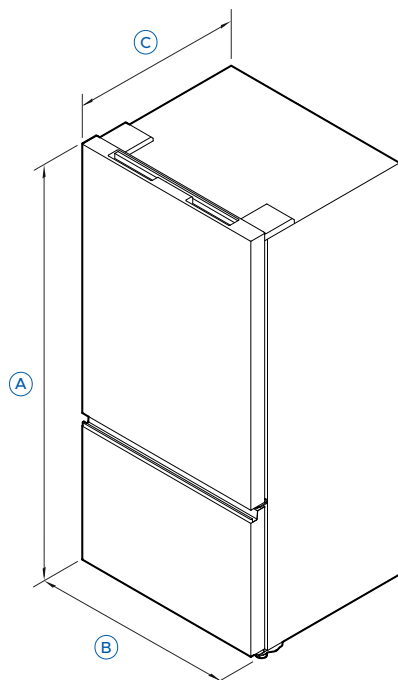

	mm
<b>A</b> Overall height	1725
<b>B</b> Overall width (door closed)	790
Overall width (door open)	1249
<b>C</b> Overall depth (door closed)	707
Overall depth (door open)	1439

## CAVITY DIMENSIONS

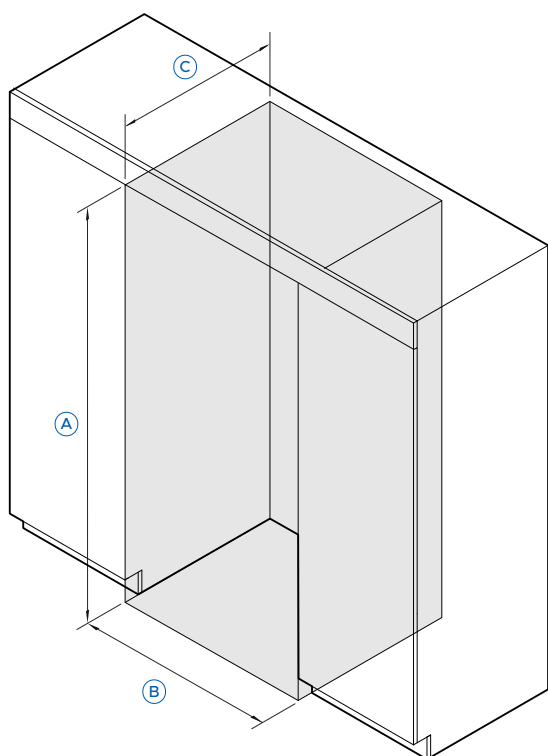

	mm
<b>A</b> Overall height of cavity	1775
<b>B</b> Overall width of cavity	890
<b>C</b> Minimum depth of cavity	757

## SERVICES

- Supply 220-240 V, 50 Hz
- Service 10 A
- Connection Plug with flex cord

The models shown in this Specification Guide (SG) may not be available in all markets and are subject to change at any time. Product specifications may vary from those shown. This SG should not be used as installation guidance for any product. Further information is required to safely and correctly install the products featured here. Specific installation guidance will be available with the product on delivery and on our website [haier.com](http://haier.com)