

FISHER & PAYKEL

FRONT LOADER WASHING MACHINE & DRYER PAIRING GUIDE

INSTALLATION GUIDE

UK IE

SIDE BY SIDE INSTALL - PAIRING MATRIX

		DRYERS									
WASHERS	MODELS	DE8060P2	DE8060P3	DH8060P1	DH8060P3	DH9060P1	DH9060P2	DH9060PG2	DH9060C1	DH9060FS1	DH9060FSG1
	WH1260F*					•	•		•	•	
	WH1160F2					•	•		•	•	
	WH1160FG2							•			•
	WH1060S1					•	•		•	•	
	WH1160S1					•	•		•	•	
	WH1060SG1							•			•
	WH1160P3					•	•		•	•	
	WH1060P1					•	•		•	•	
	WH1260P1					•	•		•	•	
	WH7560P2	•		•							
	WH7560J3	•		•							
	WH8060J3	•		•							
	WH8560F1	•		•							
	WH8060P2	•		•							
	WH8560P2	•		•							
	WH9060J3	•		•							
	WH8560J3	•		•							
	WH8060P1	•		•							
	WH9060P3		•		•						
WH1060P3		•		•							
WH8560P3		•		•							
WH8060P3		•		•							

Perfect Pair - Recommended pairing. Designed to compliment each other visually and mirror performance quality.

Matched Pair - Designed to compliment each other visually.

Compatible: Products are compatible overall, have subtle differences in visual and user experience

STACKED INSTALL - PAIRING MATRIX

		DRYERS								
MODELS	DE8060P2	DE8060P3	DH8060P1	DH8060P3	DH9060P1	DH9060P2	DH9060PG2	DH9060C1	DH9060FS1	DH9060FSG1
	STACKING KIT 428122				STACKING KIT 428159		STACKING KIT 99373	STACKING KIT 428159		STACKING KIT 99373
WH1260F*					•	•		•	•	
WH1160F2					•	•		•	•	
WH1160FG2							•			•
WH1060S1					•	•		•	•	
WH1160S1					•	•		•	•	
WH1060SG1							•			•
WH1160P3					•	•		•	•	
WH1060P1					•	•		•	•	
WH1260P1					•	•		•	•	
WH7560P2	•		•		X	X	X	X	X	X
WH7560J3	•		•		X	X	X	X	X	X
WH8060J3	•		•		X	X	X	X	X	X
WH8560F1	•		•							
WH8060P2	•		•							
WH8560P2	•		•							
WH9060J3	•		•							
WH8560J3	•		•							
WH8060P1	•		•							
WH9060P3		•		•						
WH1060P3		•		•						
WH8560P3		•		•						
WH8060P3		•		•						

• Perfect Pair - Recommended pairing. Designed to compliment each other visually and mirror performance quality.

• Matched Pair - Designed to compliment each other visually.

X Not suitable for stacked install - Potential safety risk

Compatible: Products are compatible overall, have subtle differences in visual and user experience

SIDE BY SIDE INSTALL - CLEARANCE & CAVITY DIMENSIONS

Front Loading Washer

WH1260, WH1160, WH1060P1,
WH1060S

Heat Pump or Condensing Dryer

DH9060, DE8060, DH8060

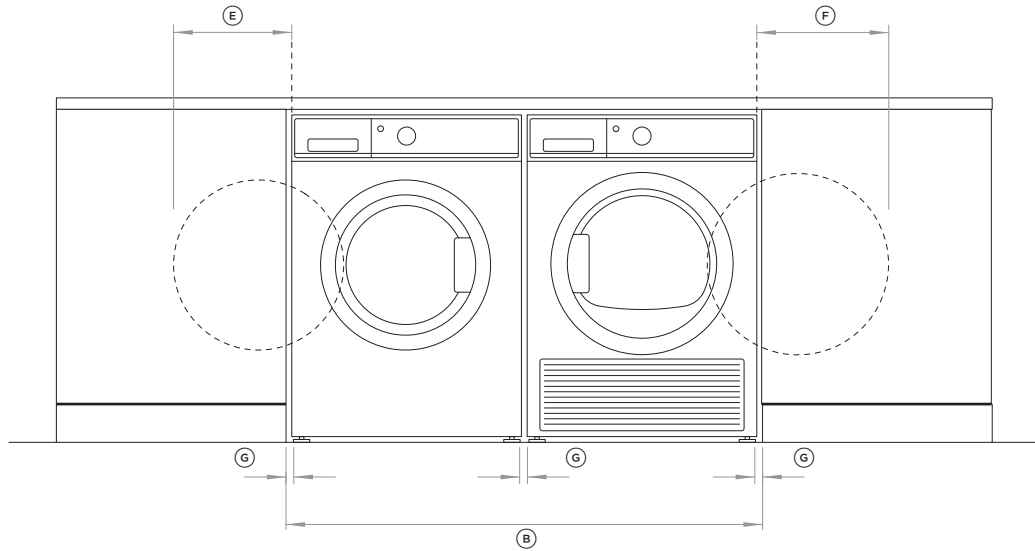

FRONT

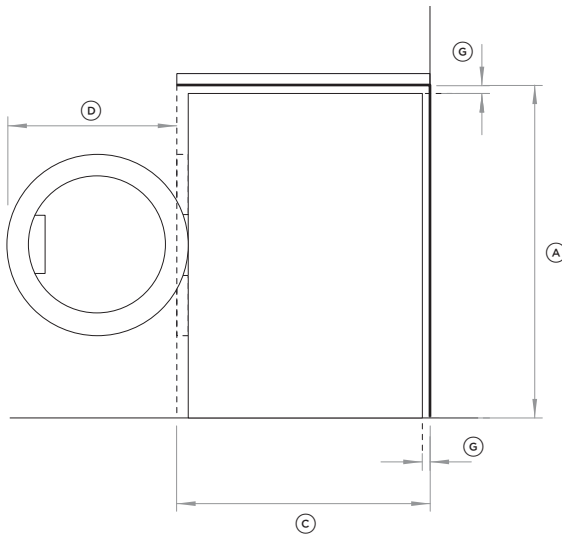

PROFILE WASHER

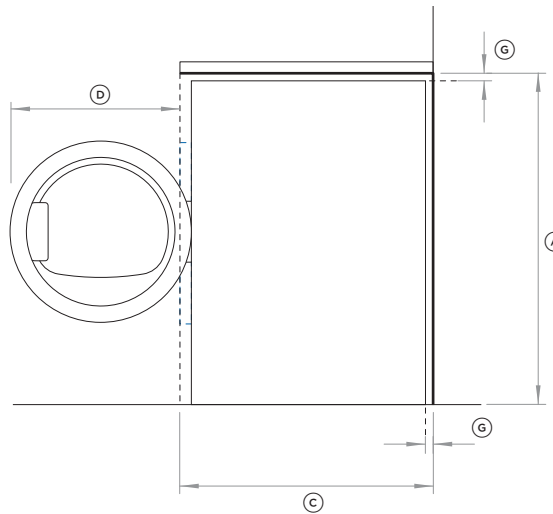

PROFILE DRYER

¹ Front panel of the product

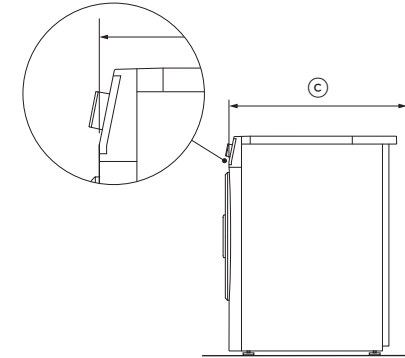

CAVITY DIMENSIONS

MM

Ⓐ	Minimum cavity height	870
Ⓑ	Minimum cavity width	1260
Ⓒ	Minimum cavity depth	
	• Flush with front panel of the product ¹	655
	• In cupboard	715

CLEARANCE DIMENSIONS

MM

Ⓓ	Depth of door (widest opening, deepest product)	450
Ⓔ	Minimum washer door clearance to adjacent wall	355
Ⓕ	Minimum dryer door clearance to adjacent wall	335
Ⓖ	Minimum gap clearance to adjacent product or cabinetry ²	20

² Applies to sides, top, rear and between products

SIDE BY SIDE INSTALL - PLUMBING & ELECTRICAL

Front Loading Washer

WH1260, WH1160, WH1060P1, WH1060S

Heat Pump or Condensing Dryer

DH9060, DE8060, DH8060

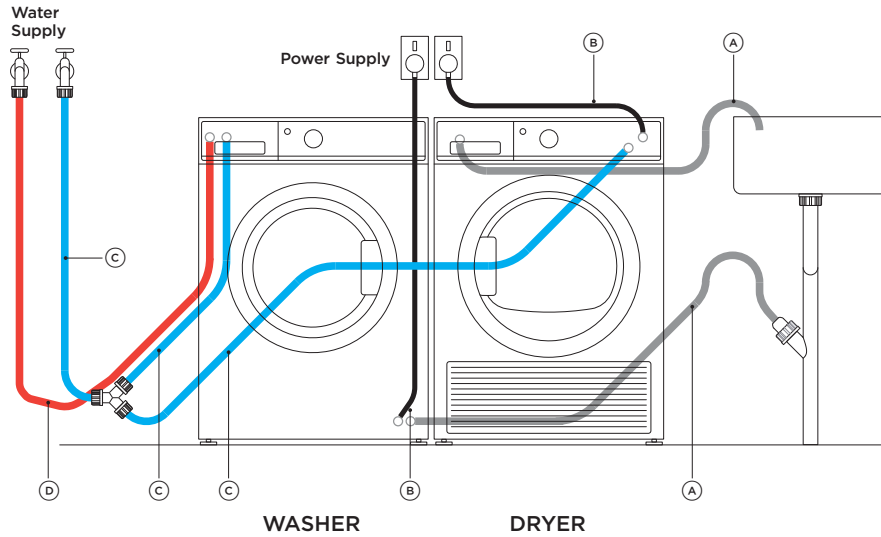

WASHER

DRYER

SERVICE DIMENSION	WASHER	DRYER
	MM	MM
Ⓐ Length of drain hoses	1600	1300
Ⓑ Length of power cord	2000	1500
Ⓒ Length of cold water inlet hose ¹	1500	650*
Ⓓ Length of hot water inlet hose	1500	n/a

¹ Dryer cold water inlet hose is only present on DH9060FS model dryers

* Cold water inlet hoses can be interchanged between washer and dryer

SPECIFICATIONS

ELECTRICAL

Supply 220-240 V, 50 Hz

Service 10 amp circuit

PLUMBING

Pressure max 1 MPa (150psi)
min 30 kPa (4.5psi)
min 50 kPa (7.3psi)¹

Flow rate at tap min. 6 litres/minute

Cold water temp max 35°C

Hot water temp max 65°C

Hot water inlet may not be an option for your washer model, refer to your washer installation guide.

¹ WH1260F, WH1160F, WH1160S, WH1060S

WASHER DRAINAGE HEIGHTS

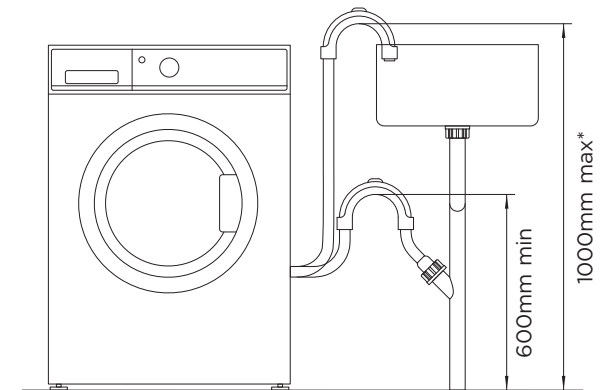

* Recommended standpipe height is 800mm

SIDE BY SIDE INSTALL - CLEARANCE & CAVITY DIMENSIONS

Front Loading Washer
WH8060J, WH7560

Heat Pump or Condensing Dryer
DH9060, DE8060, DH8060

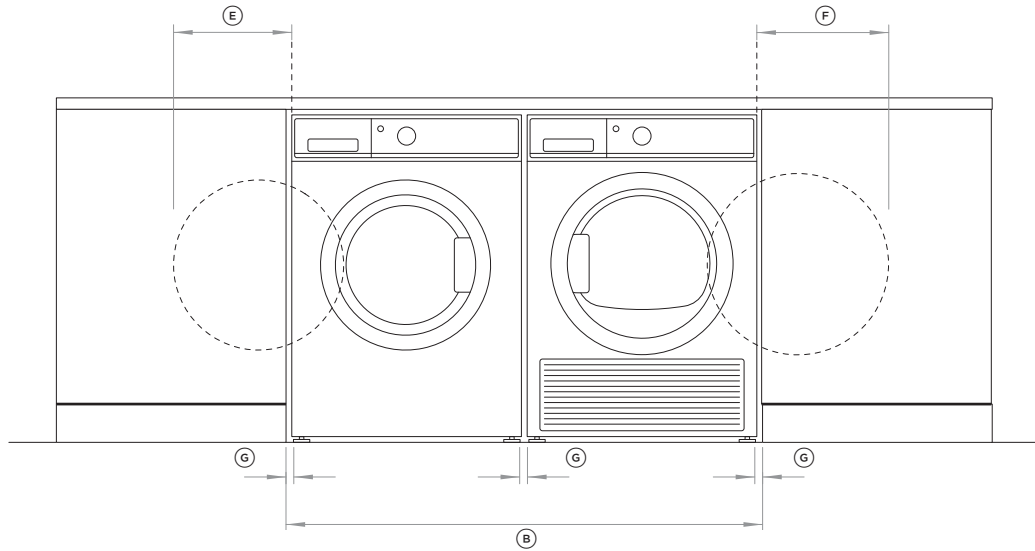

FRONT

¹ Front panel of the product

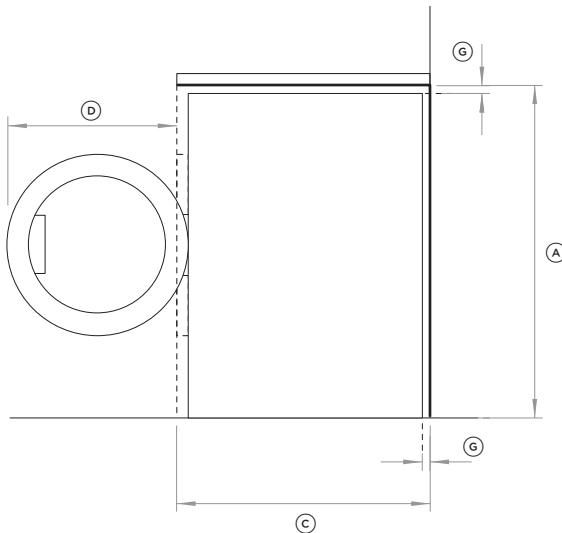
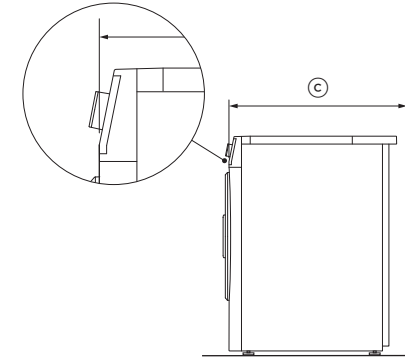

PROFILE WASHER

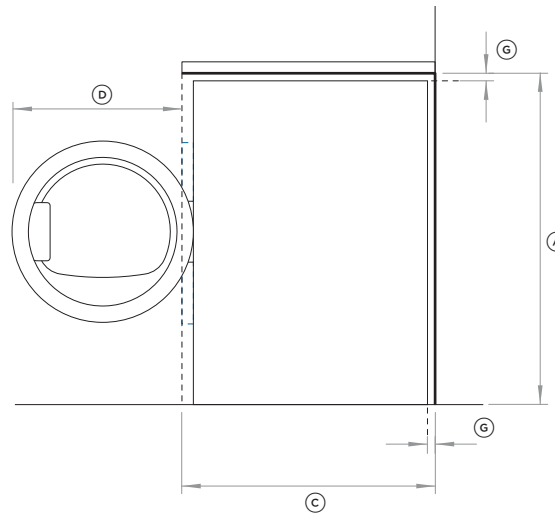

PROFILE DRYER

CAVITY DIMENSIONS

MM

Ⓐ	Minimum cavity height	870
Ⓑ	Minimum cavity width	1260
Ⓒ	Minimum cavity depth	
	• Flush with front panel of the product ¹	640
	• In cupboard	705

CLEARANCE DIMENSIONS

MM

Ⓓ	Depth of door (widest opening, deepest product)	450
Ⓔ	Minimum washer door clearance to adjacent wall	355
Ⓕ	Minimum dryer door clearance to adjacent wall	335
Ⓖ	Minimum gap clearance to adjacent product or cabinetry ²	20

² Applies to sides, top, rear and between products

SIDE BY SIDE INSTALL - PLUMBING & ELECTRICAL

Front Loading Washer
WH8060J, WH7560

Heat Pump or Condensing Dryer
DH9060, DE8060, DH8060

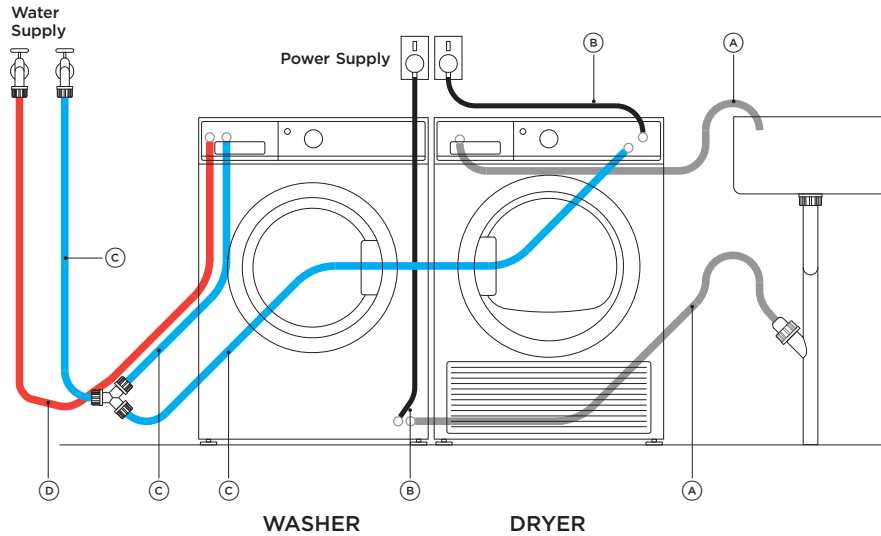

SERVICE DIMENSION	WASHER	DRYER
	MM	MM
Ⓐ Length of drain hoses	1600	1300
Ⓑ Length of power cord	1500	1500
Ⓒ Length of cold water inlet hose ¹	1500	650*
Ⓓ Length of hot water inlet hose ²	1500	n/a

¹ Only present for DH9060FS model dryers

² Only present for WH7560P2 model washers

* Cold water inlet hoses can be interchanged between washer and dryer

SPECIFICATIONS

ELECTRICAL

Supply 220-240 V, 50 Hz

Service 10 amp circuit

PLUMBING

Pressure max 1 MPa (150psi)
min 30 kPa (4.5psi)

Flow rate at tap min. 6 litres/minute

Cold water temp max 35°C

Hot water temp max 65°C

Hot water inlet may not be an option for your washer model, refer to your washer installation guide.

WASHER DRAINAGE HEIGHTS

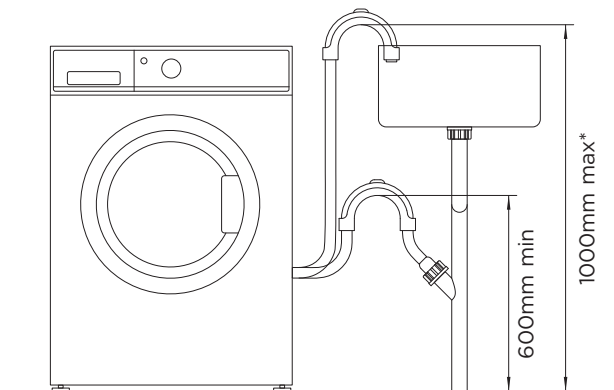

* Recommended standpipe height is 800mm

SIDE BY SIDE INSTALL - CLEARANCE & CAVITY DIMENSIONS

Front Loading Washer
 WH1060P3, WH9060, WH8560
 WH8060P

Heat Pump or Condensing Dryer
 DH9060, DE8060, DH8060

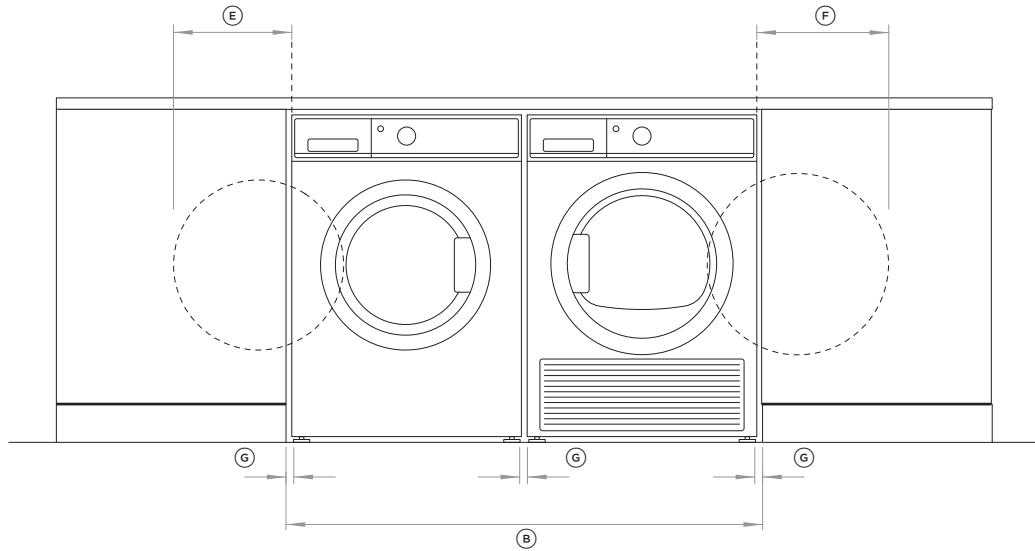

FRONT

¹ Front panel of the product

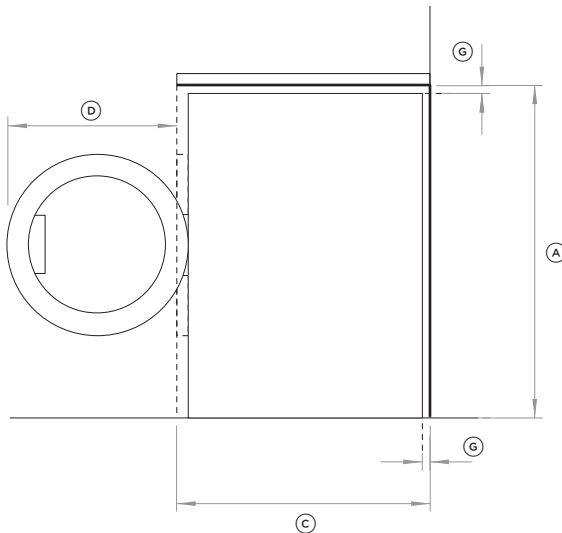
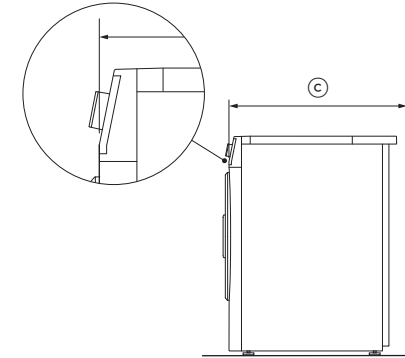

PROFILE WASHER

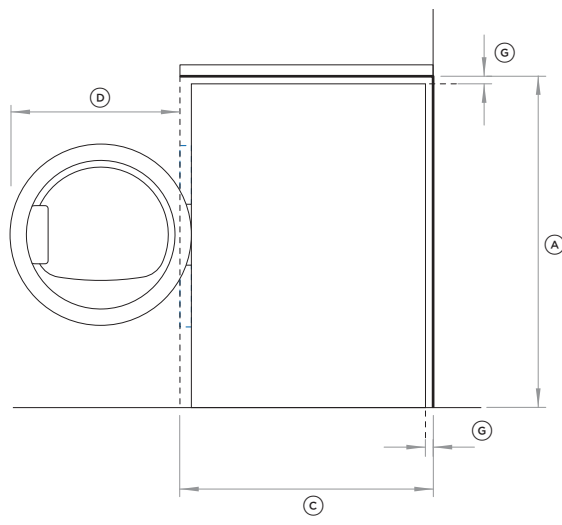

PROFILE DRYER

CAVITY DIMENSIONS

MM

Ⓐ	Minimum cavity height	870
Ⓑ	Minimum cavity width	1260
Ⓒ	Minimum cavity depth	
	• Flush with front panel of the product ¹	650
	• In cupboard	705

CLEARANCE DIMENSIONS

MM

Ⓓ	Depth of door (widest opening, deepest product)	450
Ⓔ	Minimum washer door clearance to adjacent wall	355
Ⓕ	Minimum dryer door clearance to adjacent wall	335
Ⓖ	Minimum gap clearance to adjacent product or cabinetry ²	20

² Applies to sides, top, rear and between products

SIDE BY SIDE INSTALL - PLUMBING & ELECTRICAL

Front Loading Washer
WH1060P3, WH9060, WH8560
WH8060P

Heat Pump or Condensing Dryer
DH9060, DE8060, DH8060

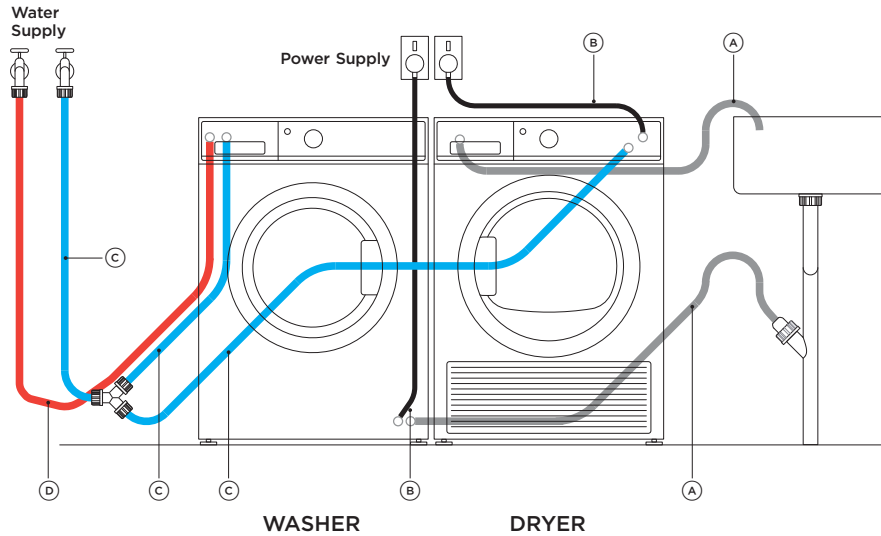

SERVICE DIMENSION	WASHER	DRYER
	MM	MM
Ⓐ Length of drain hoses	1500	1300
Ⓑ Length of power cord	1500	1500
Ⓒ Length of cold water inlet hose ¹	1500	650*
Ⓓ Length of hot water inlet hose ²	1500	n/a

¹ Only present for DH9060FS model dryers

² Only present for WH8060

* Cold water inlet hoses can be interchanged between washer and dryer

SPECIFICATIONS

ELECTRICAL

Supply 220-240 V, 50 Hz

Service 10 amp circuit

PLUMBING

Pressure max 1 MPa (150psi)
min 30 kPa (4.5psi)

Flow rate at tap Min. 6 litres/minute

Cold water temp max 35°C

Hot water temp max 65°C

Hot water inlet may not be an option for your washer model, refer to your washer installation guide.

WASHER DRAINAGE HEIGHTS

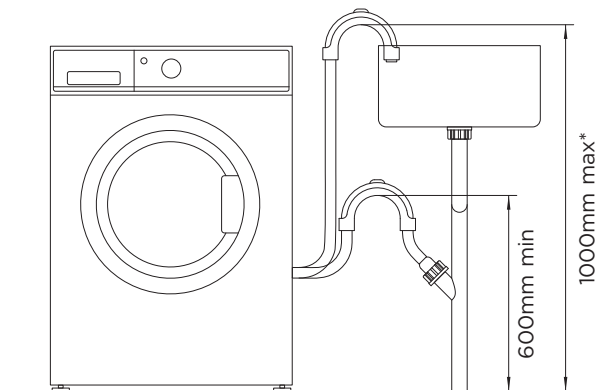

* Recommended standpipe height is 800mm

STACKED INSTALL - CLEARANCE & CAVITY DIMENSIONS

Front Loading Washer

WH1260, WH1160,
WH1060P1, WH1060S

Heat Pump Dryer

DH9060

Stacking kit

428159 (white)
& 99373 (graphite)

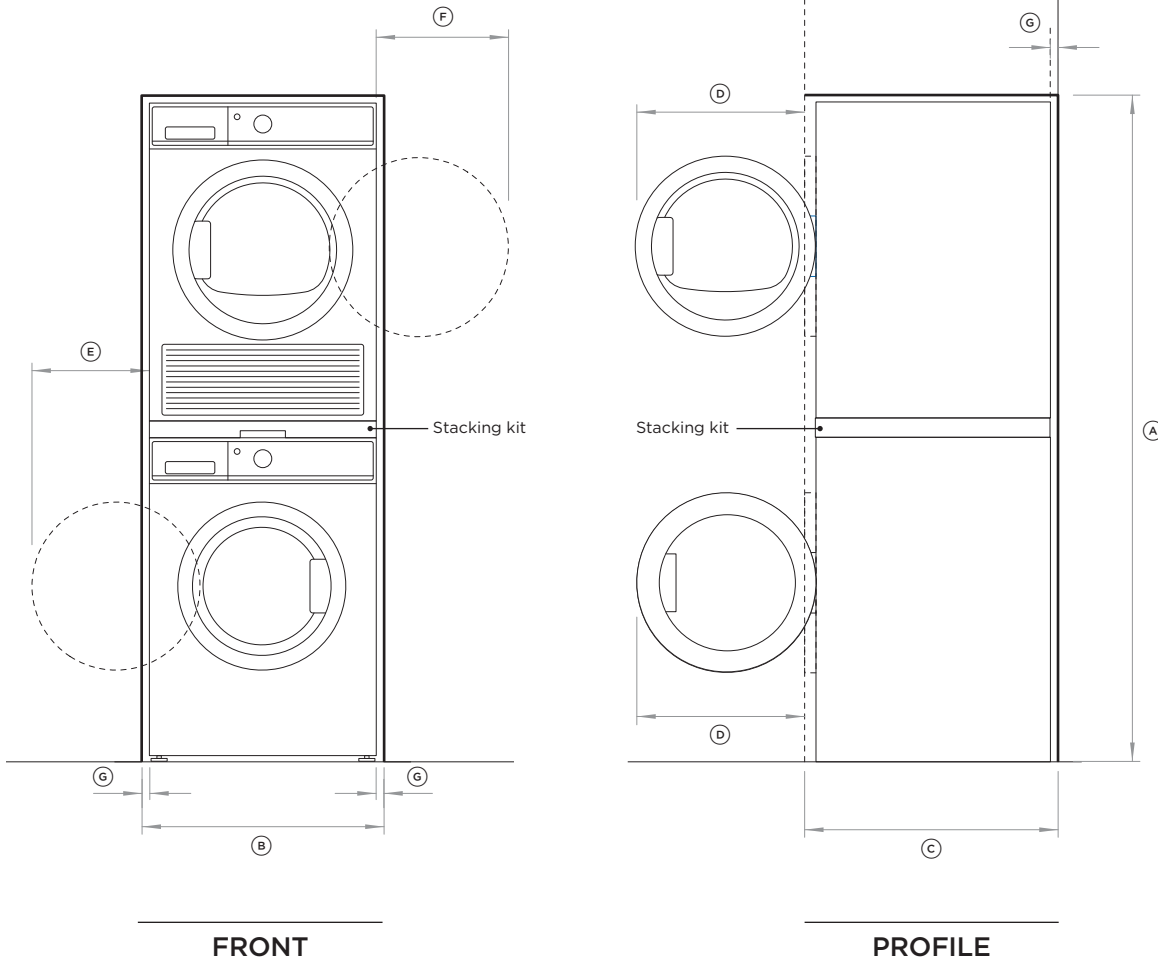

¹ Front panel of the product

CAVITY DIMENSIONS		MM
Ⓐ	Minimum cavity height	1750
Ⓑ	Minimum cavity width	640
Ⓒ	Minimum cavity depth	
	• Flush with front panel of the product ¹	655
	• In cupboard	715
CLEARANCE DIMENSIONS		MM
Ⓓ	Depth of door (widest opening, deepest product)	450
Ⓔ	Minimum washer door clearance to adjacent wall	355
Ⓕ	Minimum dryer door clearance to adjacent wall	335
Ⓖ	Minimum gap clearance to adjacent product or cabinetry ²	20

² Applies to sides, top, rear and between products

STACKED INSTALL - PLUMBING & ELECTRICAL

Front Loading Washer

WH1260, WH1160,
WH1060P1, WH1060S

Heat Pump Dryer

DH9060

Stacking kit

428159 (white)
& 99373 (graphite)

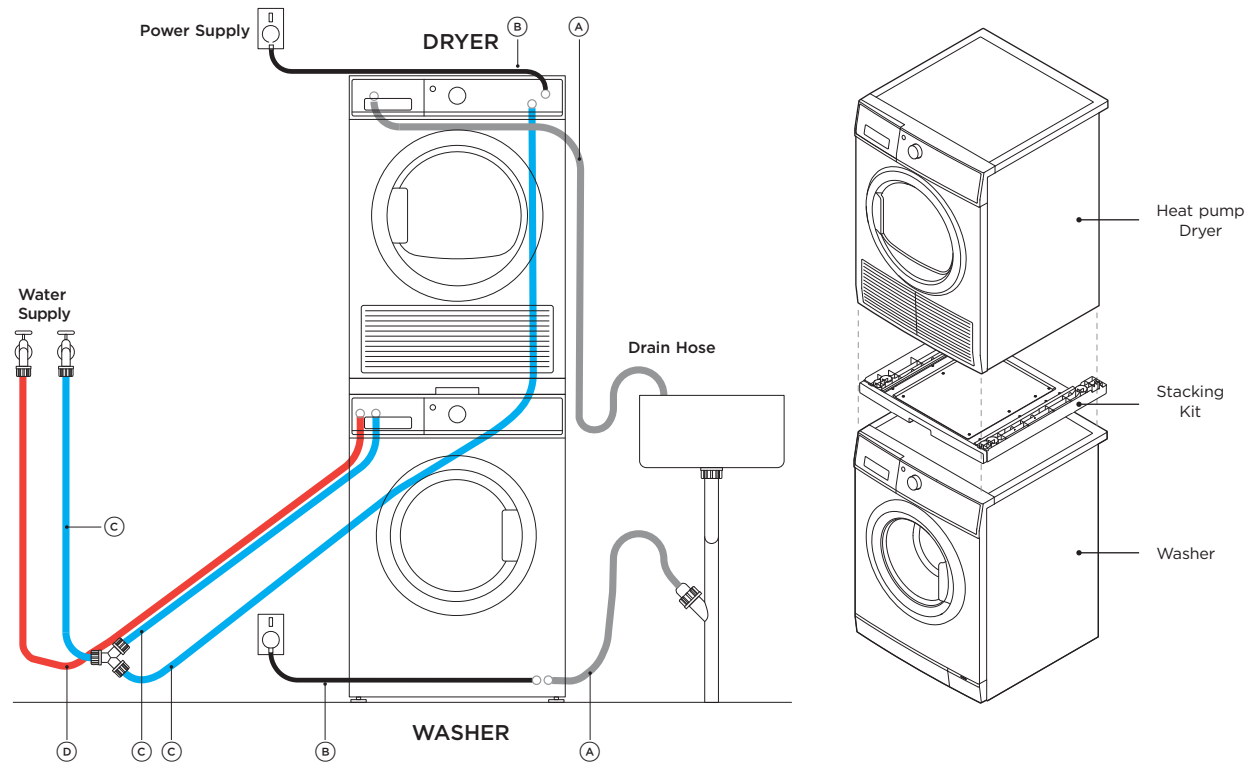

SPECIFICATIONS

ELECTRICAL

Supply	220-240 V, 50 Hz
Service	10 amp circuit

PLUMBING

Pressure	max 1 MPa (150psi) min 30 kPa (4.5psi) min 50 kPa (7.3psi) ¹
Flow rate at tap	min. 6 litres/minute
Cold water temp	max 35°C
Hot water temp	max 65°C

Hot water inlet may not be an option for your washer model, refer to your washer installation guide.

¹ WH1260F, WH1160F, WH1160S, WH1060S

WASHER DRAINAGE HEIGHTS

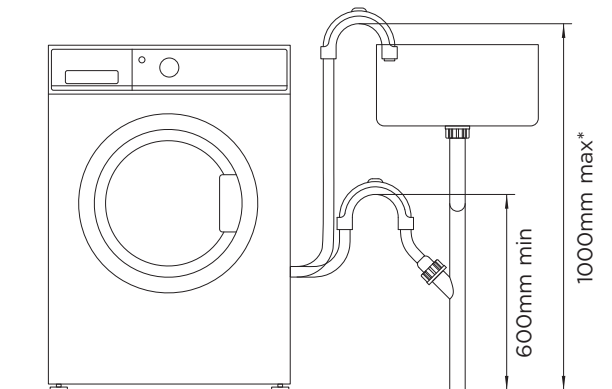

* Recommended standpipe height is 800mm

SERVICE DIMENSION

	WASHER	DRYER
	MM	MM
(A) Length of drain hoses	1600	1300
(B) Length of power cord	2000	1500
(C) Length of cold water inlet hose ¹	1500	650*
(D) Length of hot water inlet hose	1500	n/a

¹ Only present for DH9060FS model dryers

* Cold water inlet hoses can be interchanged between washer and dryer

STACKED INSTALL - CLEARANCE & CAVITY DIMENSIONS

Front Loading Washer
WH8060J, WH7560

Heat pump Dryer
DE8060, DH8060P

Stacking kit
428122

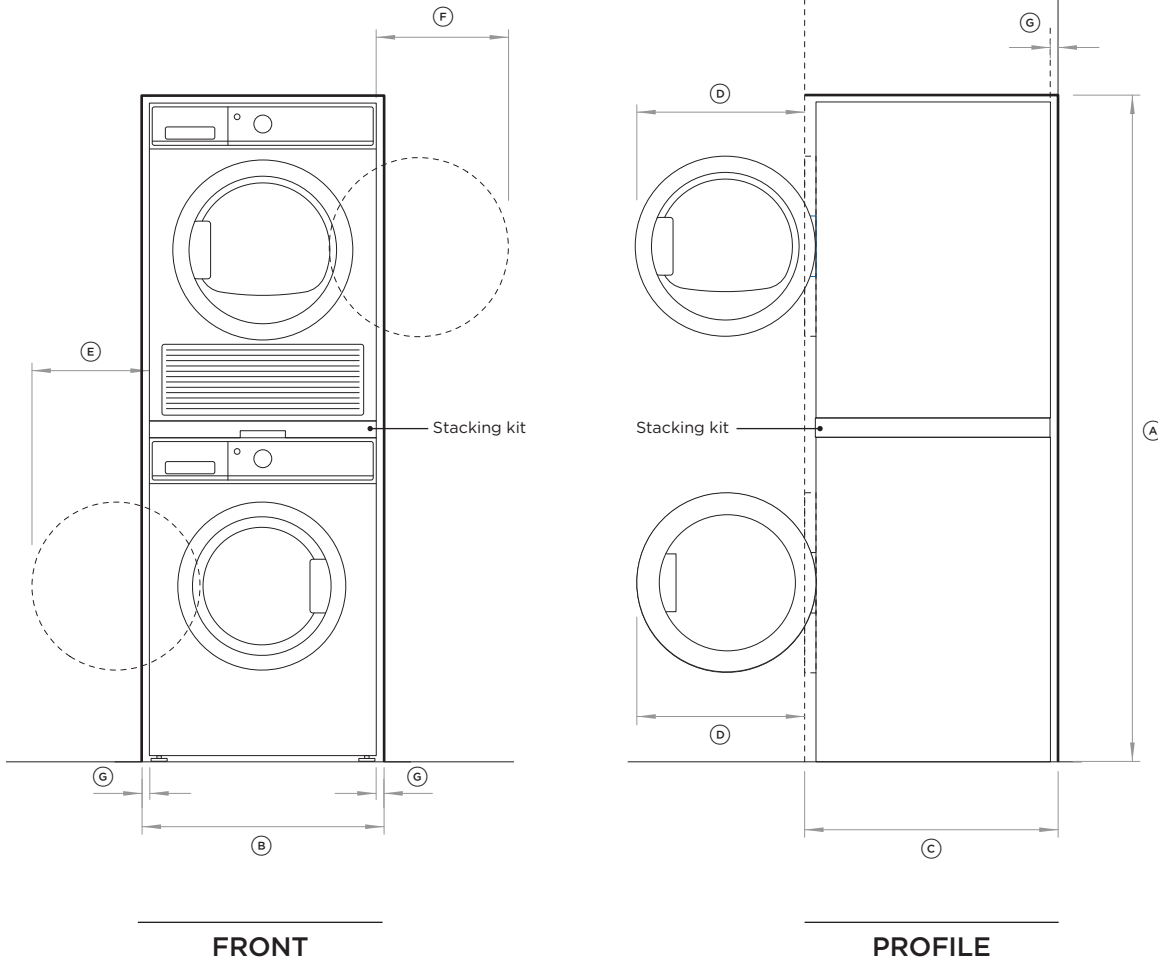

¹ Front panel of the product

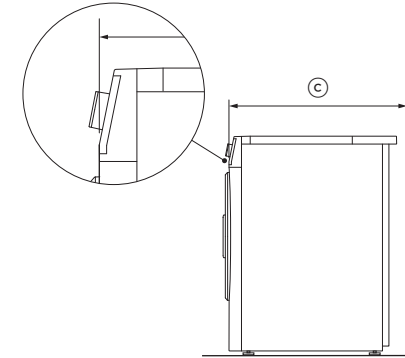

CAVITY DIMENSIONS		MM
Ⓐ	Minimum cavity height	1750
Ⓑ	Minimum cavity width	640
Ⓒ	Minimum cavity depth	
	• Flush with front panel of the product ¹	635
	• In cupboard	685
CLEARANCE DIMENSIONS		MM
Ⓓ	Depth of door (widest opening, deepest product)	450
Ⓔ	Minimum washer door clearance to adjacent wall	355
Ⓕ	Minimum dryer door clearance to adjacent wall	335
Ⓖ	Minimum gap clearance to adjacent product or cabinetry ²	20

² Applies to sides, top, rear and between products

STACKED INSTALL - PLUMBING & ELECTRICAL

Front Loading Washer
WH8060J, WH7560

Heat pump Dryer
DE8060, DH8060P

Stacking kit
428122

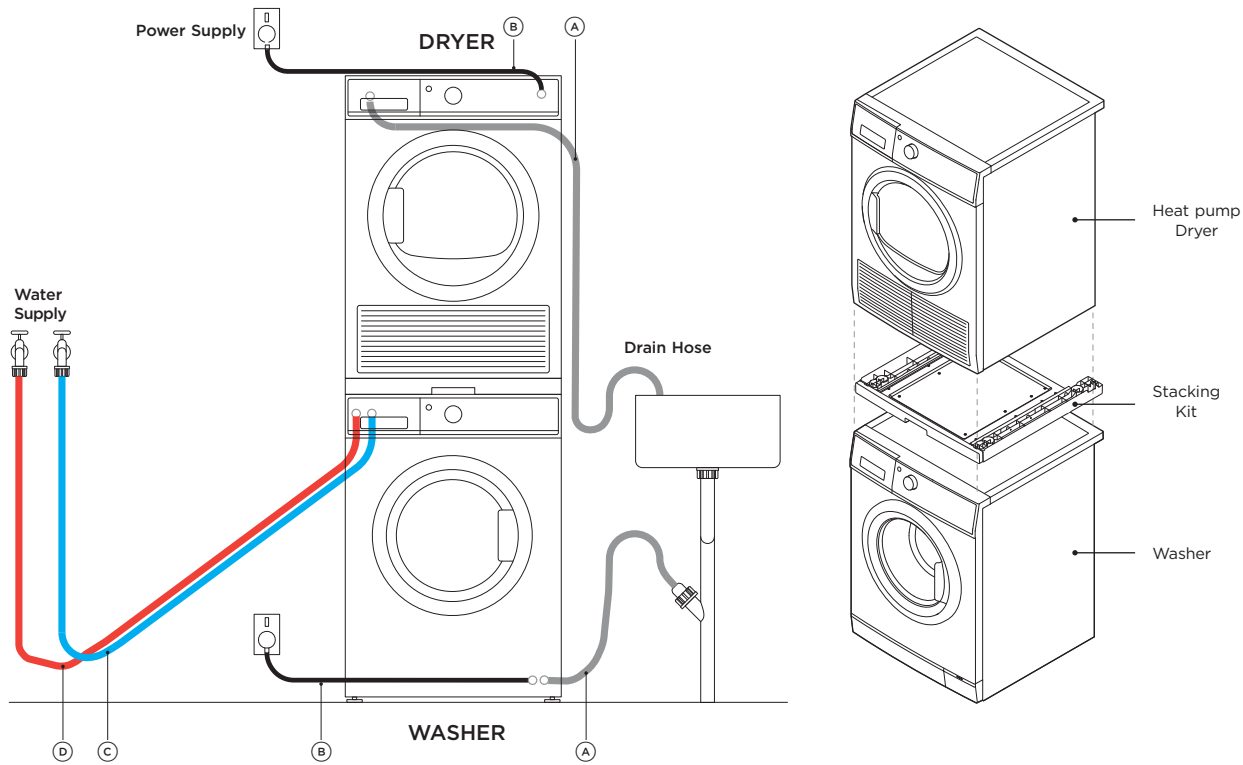

SPECIFICATIONS

ELECTRICAL	
Supply	220-240 V, 50 Hz
Service	10 amp circuit
PLUMBING	
Pressure	max 1 MPa (150psi) min 30 kPa (4.5psi)
Flow rate at tap	min. 6 litres/minute
Cold water temp	max 35°C
Hot water temp	max 65°C

WASHER DRAINAGE HEIGHTS

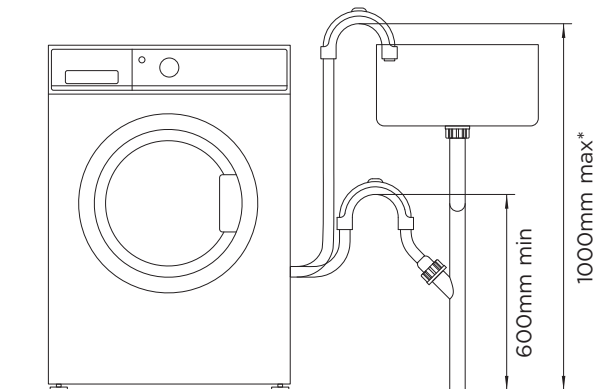

* Recommended standpipe height is 800mm

SERVICE DIMENSION	WASHER	DRYER
	MM	MM
(A) Length of drain hoses	1600	1300
(B) Length of power cord	1500	1500
(C) Length of cold water inlet hose ¹	1500	n/a
(D) Length of hot water inlet hose ²	1500	n/a

¹ Only present for DH9060FS model dryers

² Only present for WH7560P2 model washers

STACKED INSTALL - CLEARANCE & CAVITY DIMENSIONS

Front Loading Washer
WH1060P3, WH9060
WH8560, WH8060P

**Heat Pump or
Condensing Dryer**
DE8060, DH8060P

Stacking kit
428122

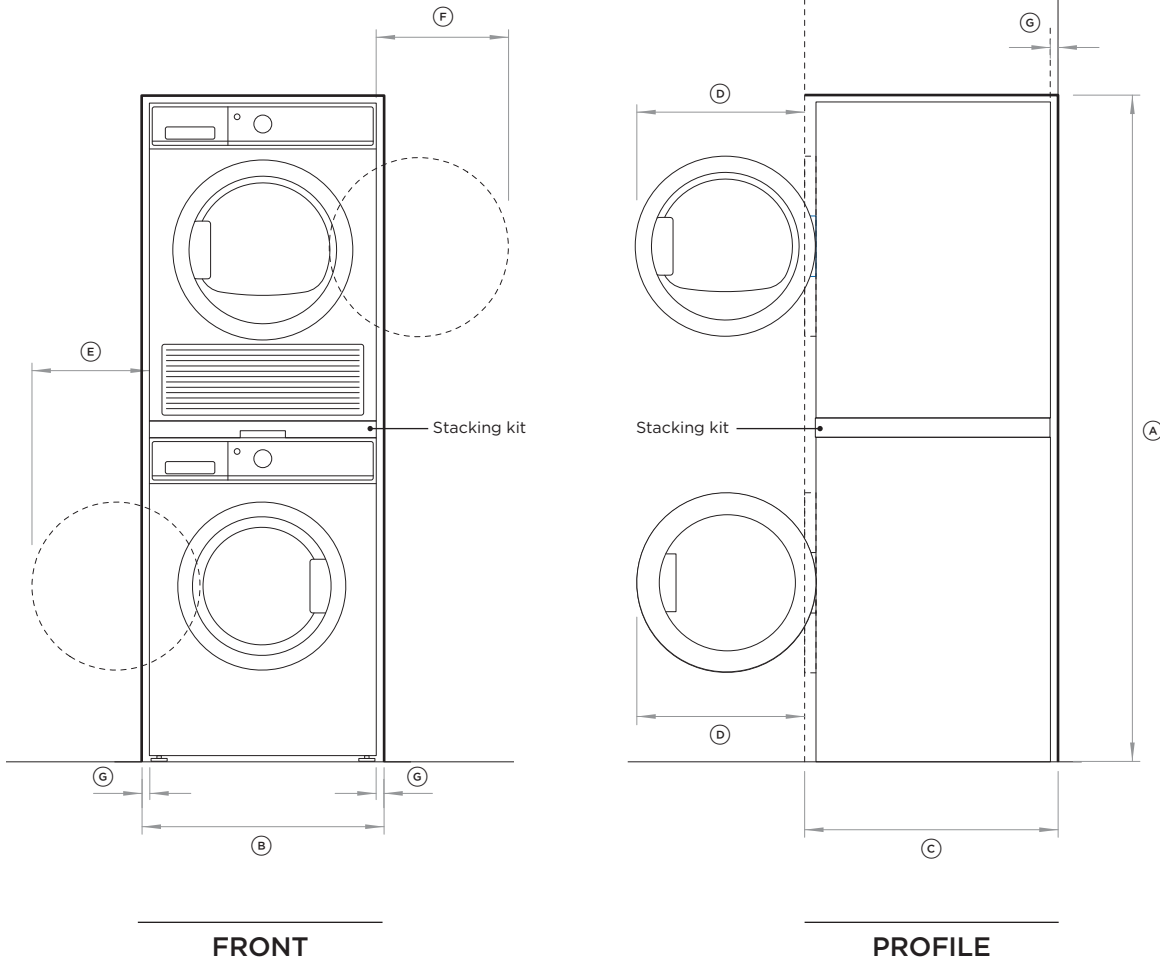

¹ Front panel of the product

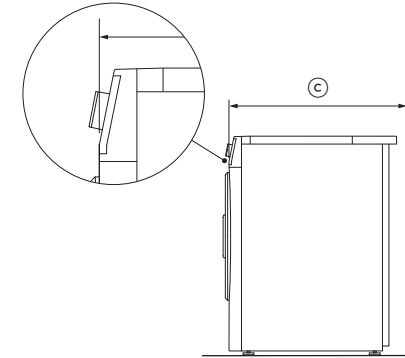

CAVITY DIMENSIONS		MM
Ⓐ	Minimum cavity height	1750
Ⓑ	Minimum cavity width	640
Ⓒ	Minimum cavity depth	
	• Flush with front panel of the product ¹	650
	• In cupboard	695

CLEARANCE DIMENSIONS		MM
Ⓓ	Depth of door (widest opening, deepest product)	450
Ⓔ	Minimum washer door clearance to adjacent wall	355
Ⓕ	Minimum dryer door clearance to adjacent wall	335
Ⓖ	Minimum gap clearance to adjacent product or cabinetry ²	20

² Applies to sides, top, rear and between products

STACKED INSTALL - PLUMBING & ELECTRICAL

Front Loading Washer
WH1060P3, WH9060
WH8560, WH8060P

**Heat Pump or
Condensing Dryer**
DE8060, DH8060P

Stacking kit
428122

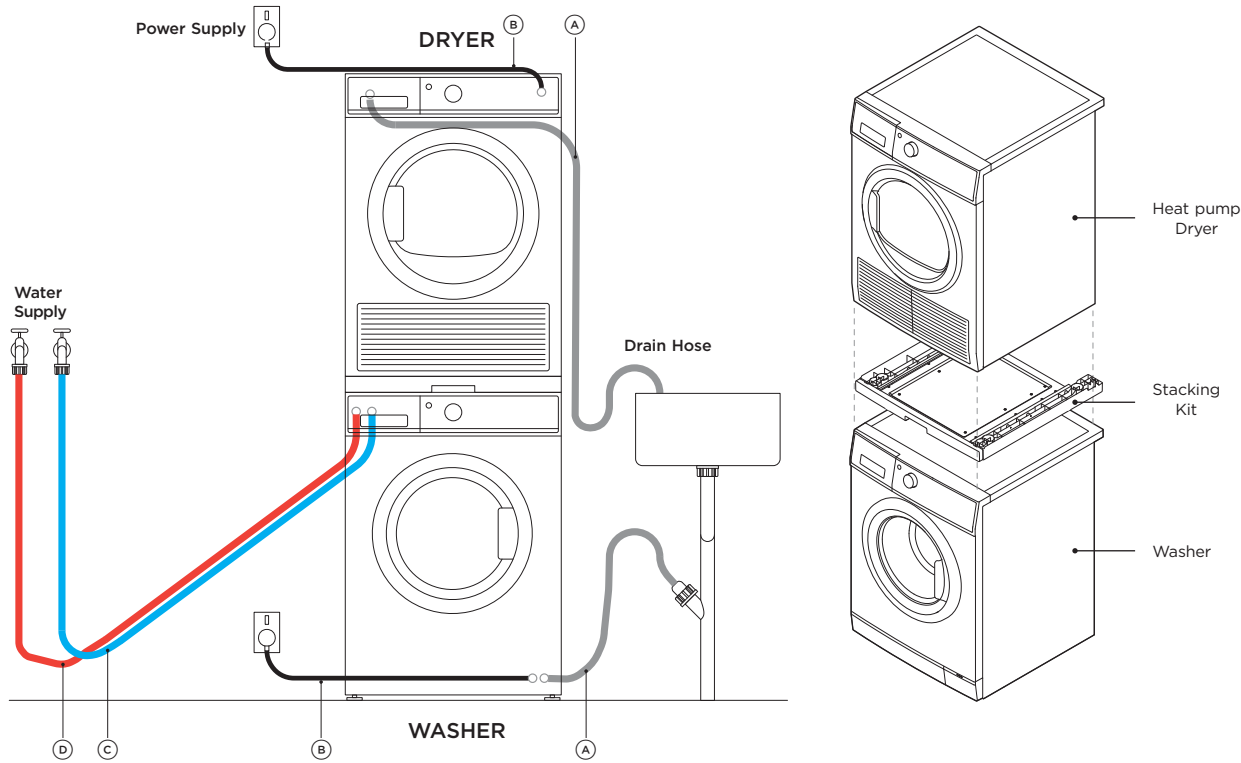

SPECIFICATIONS

ELECTRICAL

Supply	220 -240 V, 50 Hz
Service	10 amp circuit

PLUMBING

Pressure	max 1 MPa (150psi) min 30 kPa (4.5psi)
Flow rate at tap	min. 6 litres/minute
Cold water temp	max 35°C
Hot water temp	max 65°C

WASHER DRAINAGE HEIGHTS

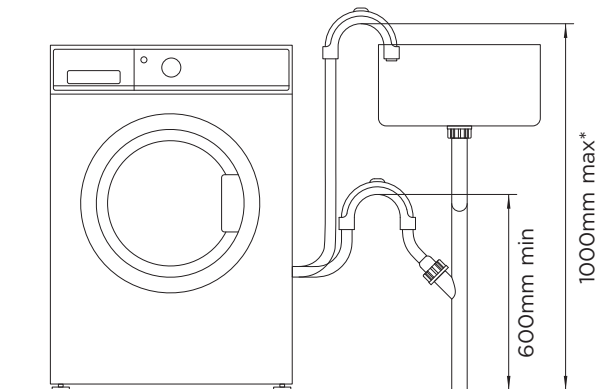

* Recommended standpipe height is 800mm

SERVICE DIMENSION	WASHER	DRYER
	MM	MM
(A) Length of drain hoses	1500	1300
(B) Length of power cord	1500	1500
(C) Length of cold water inlet hose ¹	1500	n/a
(D) Length of hot water inlet hose ²	1500	n/a

¹ Only present for DH9060FS model dryers

² Some models of washer only

FISHERPAYKEL.COM

© Fisher & Paykel Appliances 2022. All rights reserved.

The models shown in this guide may not be available in all markets
and are subject to change at any time.

The product specifications in this guide apply to the specific products and
models described at the date of issue. Under our policy of continuous product
improvement, these specifications may change at any time.

For current details about model and specification availability in your country,
please go to our website or contact your local Fisher & Paykel dealer.

428281C 11.22